



Index

1.	Features and Applications	4
2.	Safety	5
2.1	General Information	5
2.2	Notes on Legal Requirements	6
2.3	Notes on Transport, Storage and Handling	7
2.4	Notes on Operation	8
2.5	Notes on Maintenance	8
3.	Setup of the Rotary Encoder	9
4.	Graduated Disks	9
4.1	Graduated Disks - Types	10
5.	Scanning Head	11
6.	Technical Data	12
6.1	Resolution and Accuracy (Definition)	12
6.2	Resolution	12
6.3	Accuracy	12
6.4	Mechanical Data	13
6.5	Calculation of the Attainable Speed of Rotation	13
6.6	Electrical Data	14
6.7	Switch-On Behaviour	14
6.8	Ambient Conditions	15
6.9	Cable	15
6.10	Connector	15
6.11	PIN Assignment	16
6.12	Electromagnetic Compatibility (EMC)	17
6.13	Shielding Concepts	18
6.14	Voltage Output $1 V_{PP}$	19
6.15	Square-Wave Output RS 422	20
6.16	Online Compensation (Offset and Amplitude Control)	21
7.	General Mounting Instructions	22
7.1	Delivery Contents	22
7.2	Encoder Mounting Position	22
7.3	Mounting of the Encoder System	23
7.4	Dimensions and Mounting Tolerances	24
7.5	Mounting of the Graduated Disk	26
7.6	Mounting of the Scanning Head	30

8.	Signal Adjustment with ADJUSTMENT TOOL	32
8.1	Functions of the ADJUSTMENT TOOL	32
8.2	Dynamic Offset and Amplitude Control (Online Compensation)	32
8.3	Scope of Delivery	32
8.4	EPIFLEX Software	33
9.	Cleaning	34
10.	Troubleshooting	35
11.	Ordering Key	36
11.1	Scanning Head	36
11.2	Speed Chart for RIK Series	37
11.2.1	RIK 4 with Op-Amp	37
11.2.2	RIK 4 without Op-Amp	39
11.3	Graduated Disk	41
11.4	ADJUSTMENT TOOL	42

1. Features and Applications

Position encoders in drive systems have to meet high and controversial demands. The demands opposing each other are high accuracy and resolution on the one hand and low mass, small dimensions and high measuring speed on the other hand.

- The concentration of multiple axes in rotation in very tight spaces, such as in semiconductor-producing machines, requires the miniaturization of the drives, bearings and encoders.
- High machining speeds and therefore high accelerations make low masses of the components in motion essential.

The optical RIK 4 incremental encoders from NUMERIK JENA are equipped with features which are supposed to fulfill these high requirements in an ideal way.

- Due to an interpolation circuitry which is integrated in a 15-pin D-sub connector, a resolutions down to 0.135 arc seconds is possible without any additional electronics.
- The permissible speed of rotation for a sinusoidal signal output amounts up to 22,000 rpm.
- The short-range position errors (interpolation errors) were significantly reduced by introducing an electronic compensation of amplitude and offset deviations of the coarse signals. This compensation functions without following error in all velocity ranges.

Additional features:

- Compact size and large mounting tolerances
- Low mass moment of inertia of the graduated disk
- High measuring speed
- Online compensation (dynamic offset and amplitude control)
- Optional signal interpolation up to 100-times in the connector
- Possibility of electronic signal adjustment (signal optimization after mounting)

Applications:

- Automation technology
- Rotary axes
- Drive systems, especially direct drives and torque motors
- Instruments and machines used in semiconductor industry
- Robot and handling technology
- High-precision engineering
- Metrology
- Medical technology

2. Safety

2.1 General Information

- Make sure to familiarize yourself thoroughly with the contents of these installation instructions before installing and starting up the encoder!
- Please contact the support of NUMERIK JENA GmbH or an authorized representation for further information. Please visit the NUMERIK JENA website to get the contact information.
- NUMERIK JENA GmbH is not liable for damages caused by unauthorized handling of the encoders. Any unauthorized handling leads to forfeiture of all warranty claims.
- The encoders are guaranteed to function if the mounting and operating conditions are maintained as stated in these mounting instructions.
- Make sure to follow the right sequence of the mounting steps during mounting.
- NUMERIK JENA GmbH does not assume any liability for any damages or operating errors caused by incorrect installation or operation.
- The stated tolerances must be maintained in order to achieve the accuracies listed in the specifications!
- If the machine tolerances exceed the tolerances stated in the mounting instructions, errors can occur in both the operation and during measuring. NUMERIK JENA GmbH assumes no liability for this.
- Please refer to the operating manuals and safety instructions included with the devices to ensure the reliable operation of the encoder systems, especially pertaining to:
 - Auxiliary electronic units
 - Counters
 - Displays
 - Controllers
 - Encoders
 - Base mechanical devices (machine tools)
- Please pay attention to the safety instructions and warning symbols!



Danger to the device or to the function of the device!



Pull the plug!



Highly inflammable!

2.2 Notes on Legal Requirements

- The NUMERIK JENA encoders conform to EC standards and carry the CE mark.
- NUMERIK JENA encoders fulfill the requirements of the (German) Product Safety Act (ProdSG) from November 8th, 2011.
- Connect NUMERIK JENA encoders only to subsequent electronics whose power supply is generated from PELV systems (EN 50178).
- NUMERIK JENA encoders fulfill the requirements of standard IEC 61010-1 only if the power is supplied from a secondary circuit with current limitation as per IEC 61010^{3rd Ed.}, Section 9.4 or with power limitation as per IEC 60950-1^{2nd Ed.}, Section 2.5 or from a Class 2 secondary circuit as specified in UL1310.*
- This user manual supersedes all previous editions, which thereby become invalid. The basis for ordering from NUMERIK JENA is always the user manual edition valid when the contract is made.
- Standards (ISO, EN, etc.) apply only where explicitly stated in the user manual.

* In place of IEC 61010-1^{3rd Ed.}, Section 9.4, the corresponding sections of standards DIN EN 61010-1, EN61010-1, UL 61010-1 and CAN/CSA-C22.2 No. 61010-1 can be applied and in place of IEC 62368-1^{2nd Ed.}, section 6.2.2.5 PS2 the corresponding sections of standards DIN EN62368-1, EN62368-1, UL62368-1, CAN/CSA-C22.2 No. 62368-1 can be applied.

2.3 Notes on Transport, Storage and Handling



- Please use the original packaging for transportation and storage only!
- After receiving the measuring system please check the packaging and the seal for damages first! Once opened, scratches or contaminations on the graduated disk cannot be complained anymore.
- Handle the graduated disk carefully! Its surface is sensitive to scratching.
- Small surface errors evident at the time of shipping are due to the production process. These errors are no indication for a quality defect and do not affect the encoder's functionality.
- Handle the aluminum disk carefully please and protect it especially against mechanical deformation. Unevenness of the disk influences the correct operation of the encoder.



Image 1

2.4 Notes on Operation



- Do not connect or disconnect plugs if the power is on!
- Only operate the encoder with the supply voltage stated in this product data sheet.
- Comply with applicable PIN assignment if auxiliary electronic units are connected (e.g. controller or display)!
- Integrate exposed encoders in instruments, devices or machines in such a way that these are protected against contamination.
- Protect the graduated disk against mechanical damage.
- Protect the scanning head against shock, impact and humidity.

2.5 Notes on Maintenance

- The encoder requires no maintenance whatsoever, but must be cleaned occasionally, depending on the ambient conditions.
- Modifications and repairs of the encoder may only be carried out by NUMERIK JENA GmbH or appropriately authorized persons.
- NUMERIK JENA GmbH is not liable for damages caused by unauthorized handling of the encoder. All warranty claims are forfeited by unauthorized handling.
- Exposed measuring systems are sensitive to contamination, especially the disk surface and the scanning windows for the counting and reference tracks on the scanning head.
- Particularly critical are rough and irregular contamination and deposits (e.g. oil, grease or water).
- The user has to protect the encoder from contamination by way of appropriate design measures.



- **When cleaning the encoder, ensure that no solvent flows under the graduated disk!**
- **When cleaning the components, ensure that the scanning window and graduated disk are not scratched by any deposited particles!**
- **Please also pay attention to the notes in chapter 9 „Cleaning“.**

3. Setup of the Rotary Encoder

The RIK 4 encoder consists of the following components:

- Scanning head with integrated EPIFLEX sensor module
- Graduated disk with counting track and index
- 15-pin D-Sub connector with integrated electronics

Scanning head and connector are connected by a round cable. The grating on the disk will be detected by the scanning head opto-electronically.

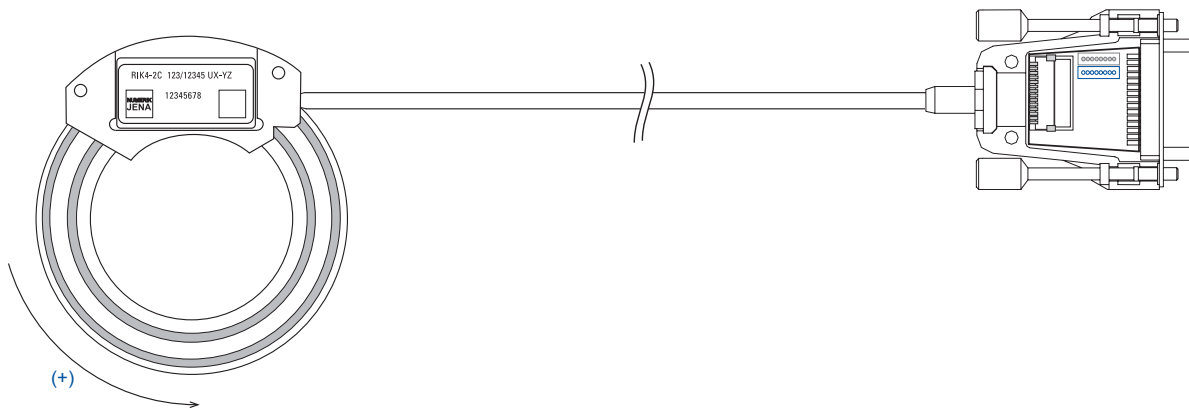

Image 2

4. Graduated Disks

The graduated disks from NUMERIK JENA are available in different sizes and versions. Hereto we have a big selection of obtainable graduated disks in supply but on request we also manufacture at customer's option.

Our graduated disks are made of an aluminium alloy. They are also available in glass on request.

thickness depends
to the material
for Aluminium = 0.5 mm
for glass on request

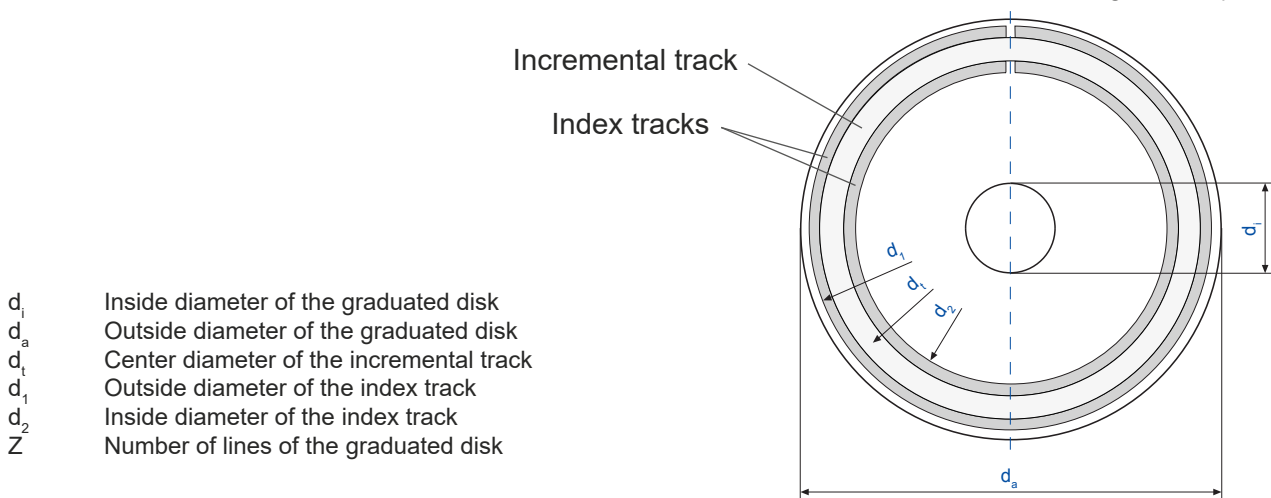

d_i Inside diameter of the graduated disk
 d_a Outside diameter of the graduated disk
 d_t Center diameter of the incremental track
 d_1 Outside diameter of the index track
 d_2 Inside diameter of the index track
 Z Number of lines of the graduated disk

Image 3

4.1 Graduated Disks - Types

Type	d_i [mm]	d_a [mm]	d_t [mm]	d_1 [mm]	d_2 [mm]	d_L [mm]	d [mm]	Z
RS 19/6/3600	6 + 0.1	26 $\begin{smallmatrix} -0.2 \\ -0.5 \end{smallmatrix}$	19	24	14	-	-	3,600
RS 19/9/3600	9 + 0.1	26 $\begin{smallmatrix} -0.2 \\ -0.5 \end{smallmatrix}$	19	24	14	-	-	3,600
RS 29/16/900	16 + 0.1	36 $\begin{smallmatrix} -0.2 \\ -0.5 \end{smallmatrix}$	29	34	24	-	-	900
RS 29/16/1000	16 + 0.1	36 $\begin{smallmatrix} -0.2 \\ -0.5 \end{smallmatrix}$	29	34	24	-	-	1,000
RS 29/16/4500	16 + 0.1	36 $\begin{smallmatrix} -0.2 \\ -0.5 \end{smallmatrix}$	29	34	24	-	-	4,500
RS 29/20/900	20 + 0.1	36 $\begin{smallmatrix} -0.2 \\ -0.5 \end{smallmatrix}$	29	34	24	-	-	900
RS 39/9,97/3600	25 + 0.1	46 $\begin{smallmatrix} -0.2 \\ -0.5 \end{smallmatrix}$	39	44	34	-	-	3,600
RS 39/25/1800	25 + 0.1	46 $\begin{smallmatrix} -0.2 \\ -0.5 \end{smallmatrix}$	39	44	34	-	-	1,800
RS 39/25/2048	25 + 0.1	46 $\begin{smallmatrix} -0.2 \\ -0.5 \end{smallmatrix}$	39	44	34	-	-	2,048
RS 39/25/3600	25 + 0.1	46 $\begin{smallmatrix} -0.2 \\ -0.5 \end{smallmatrix}$	39	44	34	-	-	3,600
RS 39/25/6000	25 + 0.1	46 $\begin{smallmatrix} -0.2 \\ -0.5 \end{smallmatrix}$	39	44	34	-	-	6,000
RS 39/30/3600	30 + 0.1	46 $\begin{smallmatrix} -0.2 \\ -0.5 \end{smallmatrix}$	39	44	34	-	-	3,600
RS 45/30/9000	30 + 0.1	54 $\begin{smallmatrix} -0.2 \\ -0.5 \end{smallmatrix}$	45	50	40	-	-	9,000
RS 64/48,5/2048	48,5 + 0.1	71 $\begin{smallmatrix} -0.2 \\ -0.5 \end{smallmatrix}$	64	69	59	-	-	2,048
RS 64/48,5/4096	48,5 + 0.1	71 $\begin{smallmatrix} -0.2 \\ -0.5 \end{smallmatrix}$	64	69	59	-	-	4,096
RS 64/48,5/9000	48,5 + 0.1	71 $\begin{smallmatrix} -0.2 \\ -0.5 \end{smallmatrix}$	64	69	59	-	-	9,000
RS 64/48,5/10000	48,5 + 0.1	71 $\begin{smallmatrix} -0.2 \\ -0.5 \end{smallmatrix}$	64	69	59	-	-	10,000
RS 92/70/3600	70 + 0.1	100 $\begin{smallmatrix} -0.2 \\ -0.5 \end{smallmatrix}$	92	97	87	-	-	3,600
RS 92/70/9000	70 + 0.1	100 $\begin{smallmatrix} -0.2 \\ -0.5 \end{smallmatrix}$	92	97	87	-	-	9,000
RS 92/70/18000	70 + 0.1	100 $\begin{smallmatrix} -0.2 \\ -0.5 \end{smallmatrix}$	92	97	87	-	-	18,000
RS 92/76/3600	76 + 0.1	100 $\begin{smallmatrix} -0.2 \\ -0.5 \end{smallmatrix}$	92	97	87	-	-	3,600
RS 92/80/3600	80 + 0.1	105 $\begin{smallmatrix} -0.2 \\ -0.5 \end{smallmatrix}$	92	97	87	-	-	3,600
RS 142/120/5400	120 + 0.2	150 $\begin{smallmatrix} -0.2 \\ -0.5 \end{smallmatrix}$	142	147	137	-	-	5,400
RS 142/120/18000	120 + 0.2	150 $\begin{smallmatrix} -0.2 \\ -0.5 \end{smallmatrix}$	142	147	137	-	-	18,000
RS 142/122/5400	122 + 0.2	150 $\begin{smallmatrix} -0.2 \\ -0.5 \end{smallmatrix}$	142	147	137	-	-	5,400
RS 142/128/18000	128 + 0.2	150 $\begin{smallmatrix} -0.2 \\ -0.5 \end{smallmatrix}$	142	147	137	-	-	18,000
RS 192/160/24000	160 + 0.2	199 $\begin{smallmatrix} -0.2 \\ -0.5 \end{smallmatrix}$	192	197	187	-	-	24,000

(other sizes on request)

Chart 1

5. Scanning Head

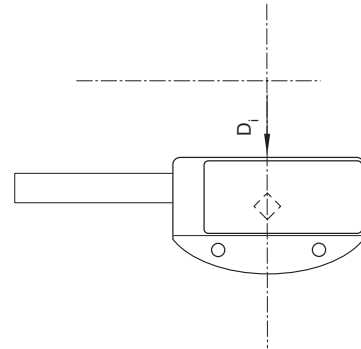
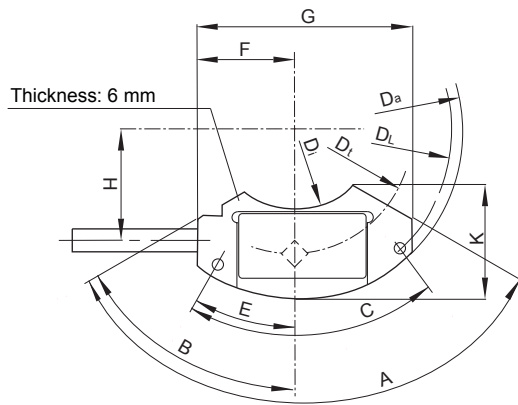

Example: RIK 4-2C 19/3600...
(with stop surface on outside diameter only)

Image 4

Type	D_a [mm]	D_t [mm]	D_i [mm]	D_L [mm]	A	B	C	E	F	G	H	K
19	38 _{h6}	19	4*	34 ±0.1	-	-	44°	22°	12	24	8	15.0
29	45 _{h6}	29	16 ^{H6}	41 ±0.1	120°	60°	82°	34°	16	34	13	18.8
39	55 _{h6}	39	26 ^{H6}	51 ±0.1	120°	60°	70°	30°	16	35	18	18.6
45	64 _{h6}	45	34 ^{H6}	60 ±0.1	120°	60°	56°	28°	16	32	20.8	18.0
64	82 _{h6}	64	50.8 ^{H6}	77 ±0.1	90°	45°	44°	22°	18	36	30	19.2
92	110 _{h6}	92	78 ^{H6}	106 ±0.1	90°	45°	34°	17°	18	36	44	18.5
142	160 _{h6}	142	126 ^{H6}	156 ±0.1	90°	45°	22°	11°	18	36	69	18.7
192	210 _{h6}	192	180 ^{H6}	206 ±0.1	-	-	10°	5°	13	26	94	15.8

* distance to the center, do not use as datum dimension

Chart 2

D_a Outside diameter of the scanning head
 D_i Inside diameter of the scanning head
 D_t Center diameter of the counting track
 D_L Hole spacing of borings for mounting screws

6. Technical Data

6.1 Resolution and Accuracy (Definition)

Basically one has to differentiate between the resolution and the accuracy of a measuring system. The two parameters are not directly interdependent and may differ from each other.

6.2 Resolution

Resolution "A" is defined as the smallest angular value that is still detected by the evaluating electronics (display, control) when the graduated disk is turned relative to the scanning head. The resolution can be calculated using the following formula:

$$A = Z \cdot i \cdot N \quad [\text{Increments/Revolution}]$$

$$A = \frac{360^\circ}{Z \cdot i \cdot N} \quad [\text{Degrees}]$$

Z	Number of lines (graduated disk)
i	Interpolation factor of the evaluation electronics (5-times, 10-times, 25-times, 50-times or 100-times)
N	Factor for evaluation mode (counter) N = 1 for single-edge evaluation N = 4 for 4-edge evaluation

6.3 Accuracy

Accuracy (extremes of direction deviations) is affected by

- Graduation errors of the graduated disk
- Eccentricity of the graduation relative to the axis bearing
- Radial eccentricity of the axis bearing
- Deviations in the positions of the graduated disk and the scanning head (mounting tolerances)
- Interpolation error in signal processing

The accuracy is largely determined by the eccentricity of the graduation relative to the axis bearing and the radial eccentricity of the axis bearing. The error resulting from these factors is calculated using the following formula:

$$\Delta\varphi = \pm 412 \frac{e}{D}$$

$\Delta\varphi$	Angular error [Arc seconds]
e	Eccentricity of the graduation relative to the rotational axis including the radial eccentricity of the axis bearing [μm]
D	Graduation diameter of the graduated disk [mm]

6.4 Mechanical Data

RIK 4	
Weight of scan head (w/o cable)	3 - 6 g
Number of counting pulses / rev. (with signal interpolation and 4-edge evaluation)	up to 9,600,000
Available diameter of graduated disks (Ø of graduation)	<ul style="list-style-type: none"> • 19 mm • 29 mm • 39 mm • 45 mm • 64 mm • 92 mm • 142 mm • 192 mm

Chart 3

6.5 Calculation of the Attainable Speed of Rotation

The maximum attainable speed of rotation of the encoder is determined by the maximum output frequency of the interpolator and/or the maximum counting frequency of the operator's evaluation electronics.

In order to avoid counting errors, the interpolator's output frequency is matched to the counting frequency of the operator's evaluation electronics.

This adaptation is possible in discrete frequency steps.

The maximum attainable speed of rotation (n_{\max}) is calculated according to the following formula:

$$n_{\max} = \frac{f \cdot 60}{i \cdot SF \cdot 4 \cdot Z} \quad [\text{rpm}]$$

f	Clock frequency of the counter [Hz]
i	Interpolation factor (5-times, 10-times, 25-times, 50-times or 100-times)
SF	Safety factor = 1.5
4	4-edge evaluation
Z	Number of lines (Graduated disk)

6.6 Electrical Data

RIK 4	
Scanning frequency	max. 500 kHz
Output Interfaces	
Voltage output	1 V _{PP} (15-pin D-Sub)
Square wave output	RS 422 with interpolation up to 100-times (15-pin D-Sub)
Supply voltage	5 V ±10%
Current Consumption	
Voltage output	≤80 mA*
Square wave output	≤210 mA*
Cable	
Cable diameter	3.7 mm
Permissible bending radius	<ul style="list-style-type: none"> occasional flexing ~8 mm constant flexing ~40 mm
Length from scan head to the D-Sub connector	3 m (standard: 0.3 m, 0.5 m, 1.0 m, 1.5 m, 2.0 m, 3.0 m)
Length from D-Sub connector to the controller	max. 100 m (The necessary supply voltage must be ensured!)

* with 120 Ω load resistance

Chart 4

6.7 Switch-On Behaviour

During power-up procedure of the encoder system the level of power voltage and signal lines must be below 250 mV.



If the encoder system will be powered-up at a residual voltage between a range of 250 and 400 mV, internal sensor parameter will not set correctly. This will lead to incorrect encoder signals.

This behaviour has to be observed especially during reset routines of controllers.

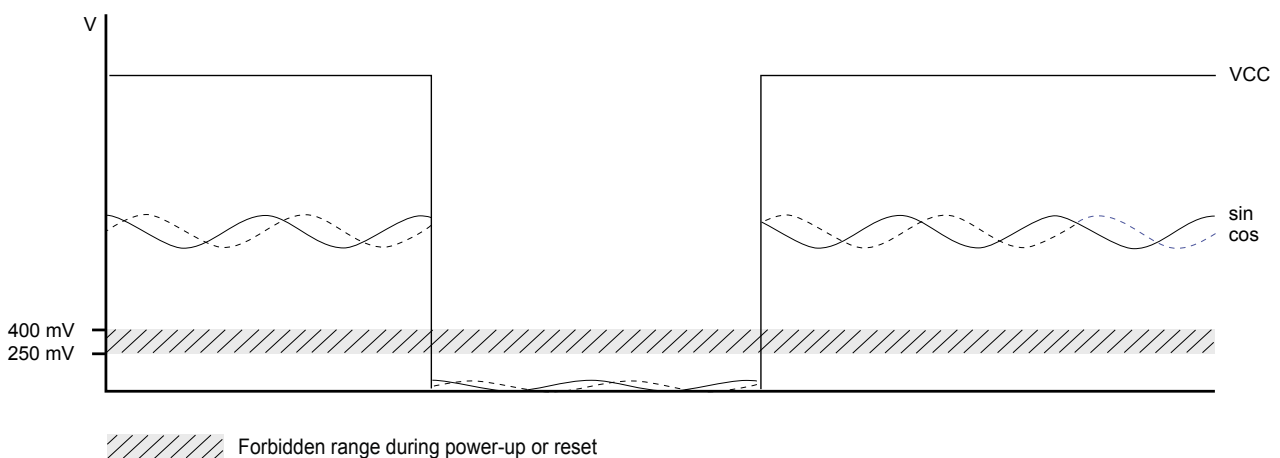

Image 5

6.8 Ambient Conditions

	RIK 4
Operating temperature range	0°C to +55°C (+32°F to +131°F)
Storage temperature range	-20°C to +70°C (-4°F to +158°F)
Vibration (50 Hz ... 2,000 Hz)	≤200 ms ⁻² (20 g)
Shock (11 ms)	≤400 ms ⁻² (40 g)
Humidity	≤93% relative humidity (no condensation forming)

Chart 5

6.9 Cable

Scanning Head Cable (connection cable from scanning head to D-Sub connector)

- Provide a strain relief for the cable near the scanning head.
- The encoder cables and connecting cables must be laid away from sources of interference (e.g. mains cables, fuses, motors, magnetic valves or power supplies). Normally a distance of ≥100 mm will be sufficient.
- Install the cable in a way that it cannot be damaged by the rotating hub. Please pay attention to the permissible bending radius (see also point 7.2)!

Extension Cable (connection cable from D-Sub connector to controller)

- Use preferably original extension cables made by NUMERIK JENA. This guarantees an optimum compatibility with the encoders and ensures a maximum protection against electromagnetic interferences.
- Please consult the technical support of NUMERIK JENA before using selfmanufactured extension cables.
- Do not install any other signal lines in the encoder cable!

6.10 Connector

15-pin D-Sub Connector

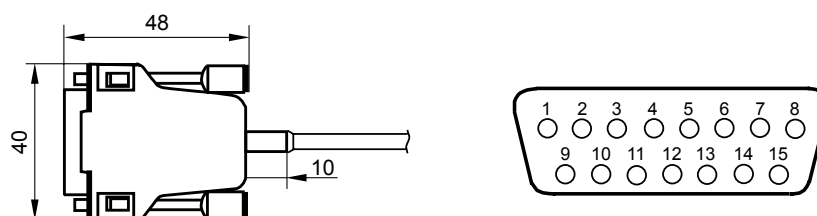

Image 6

6.11 PIN Assignment

15-pin D-Sub Connector

PIN	1	2	3	4	5	6	7	8	9	10	11	12	13	14	15	Housing
1 V _{PP}	-	-	-	U ₀₋	U ₂₋	U ₁₋	-	5V	0V	-	-	U ₀₊	U ₂₊	U ₁₊	-	Shield
RS 422	-	-	NAS	Z ₀₋	Z ₂₋	Z ₁₋	-	5V	0V	-	AS	Z ₀₊	Z ₂₊	Z ₁₊	-	Shield
Cable Ø 3.7 mm	-	-	vt	pk	rd	bn	-	bu	wh	-	ye	gy	bk	gn	-	-

1 V_{PP}

U ₁₊	Counting signal 0° (sin)
U ₁₋	Counting signal 180° (-sin)
U ₂₊	Counting signal 90° (cos)
U ₂₋	Counting signal 270° (-cos)
U ₀₊	Reference signal
U ₀₋	Negated reference signal

RS 422

Z ₁₊	Counting signal 0°
Z ₁₋	Negated counting signal 0° (180°)
Z ₂₊	Counting signal 90°
Z ₂₋	Negated counting signal 90° (270°)
Z ₀₊	Reference signal
Z ₀₋	Negated reference signal

0V Ground (GND)

5V Operating voltage (U_B)

AS Error signal (monitoring signal)

NAS Negated error signal

NAS high: Input signal within the tolerance range

NAS low: Input signal outside the tolerance range (check measuring system!)

SCL Programming wire clock

SDA Programming wire data

6.12 Electromagnetic Compatibility (EMC)



Please observe the following to ensure maximum protection against electrical and magnetic fields:

- The encoder must be mounted to a galvanic conductive surface. The mounting surfaces, the threads of the mounting screws and the threads in the machine must be free from electrically non-conductive coatings.
- Maintain the NUMERIK JENA shielding concept for the measuring system!
- Shielding for encoders without connectors:
 - When connected directly with the evaluation electronics, ensure that the external shield of the cable is well grounded
 - If cable connectors (e.g. terminal strips, etc.) are used, connect the external shields of the cables with each other and with the shielding of the cable connector
- When using additional electronics, connect the housing electrically conducting to ensure good galvanic conductivity. For insulated installation the housing should be connected at the shortest distance by an additional potential equalization line (Cu line with cross section $\geq 6 \text{ mm}^2$) with the machine's protective ground.
- Please contact the NUMERIK JENA support or that of the appropriate manufacturer if you experience any problems when working with specific display or control units.

6.13 Shielding Concepts

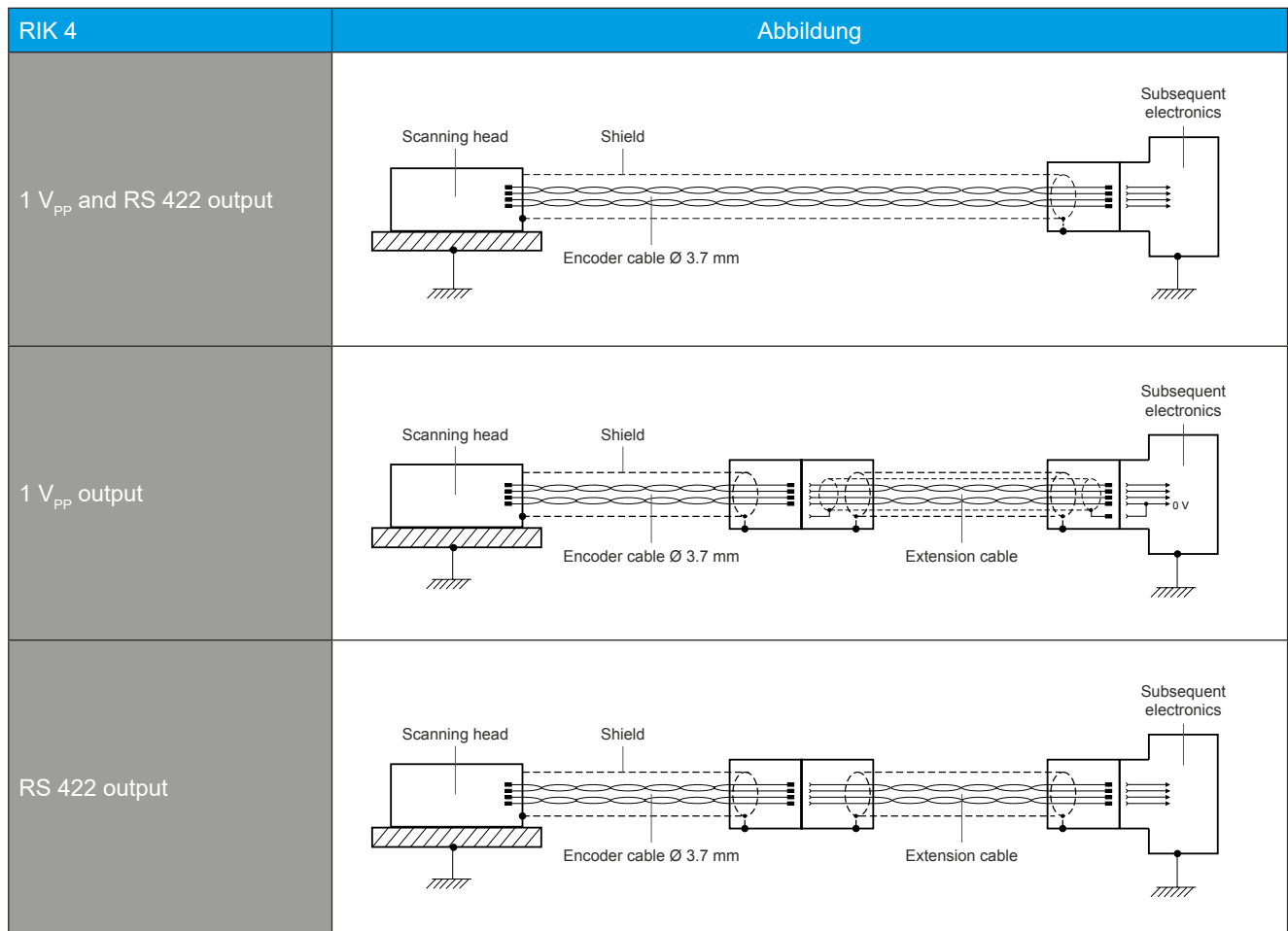

Chart 6

6.14 Voltage Output $1 V_{PP}$

Optimal Connection Circuit

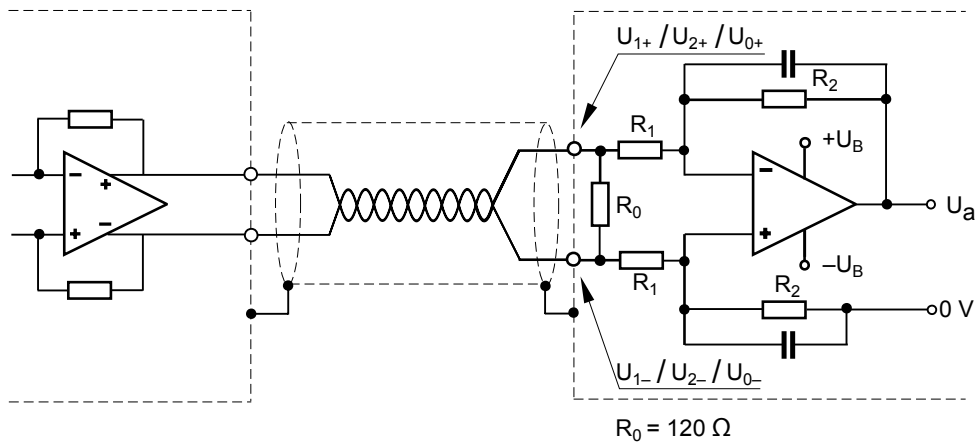

Image 7

Signal Curve

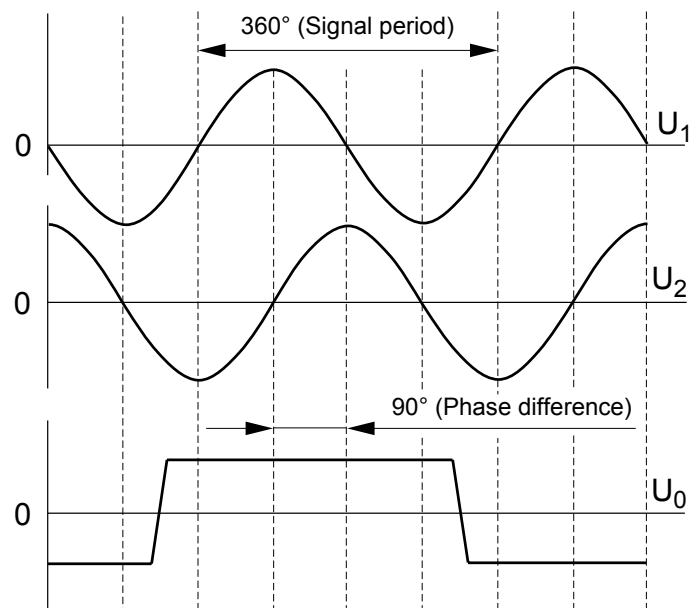

Image 8

Difference signals measured at R_0 :

$$U_1 = U_{1+} - U_{1-} = 0.6 \dots 1.2 V_{PP} \quad (\text{Rated voltage: } 1 V_{PP})$$

$$U_2 = U_{2+} - U_{2-} = 0.6 \dots 1.2 V_{PP} \quad (\text{Rated voltage: } 1 V_{PP})$$

$$U_0 = U_{0+} - U_{0-} = 0.5 \dots 1.2 V \quad (\text{Rated voltage: } 0.8 V)$$

6.15 Square-Wave Output RS 422

Optimal Connection Circuit

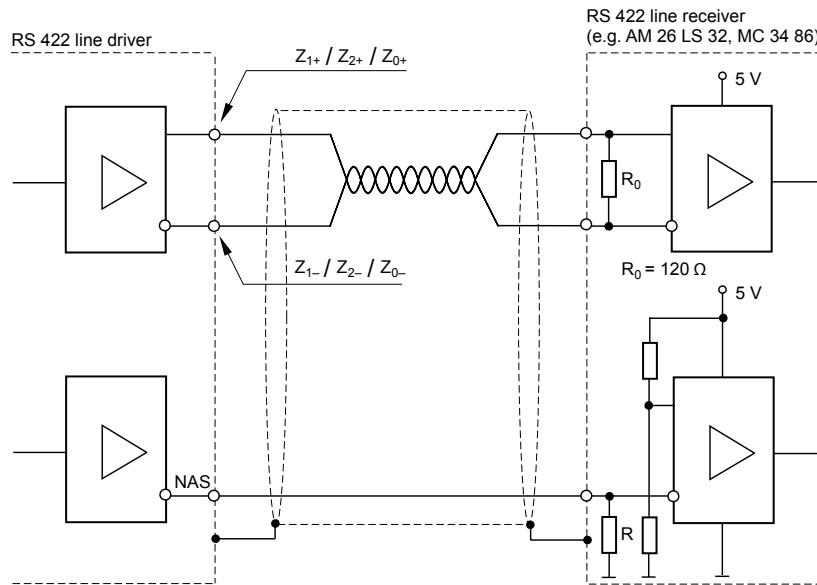

Image 9

Signal Curve

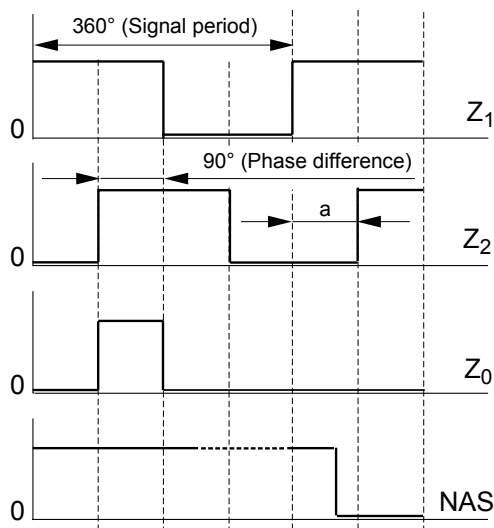

Image 10

NAS high:

Encoder functioning properly, input signals within tolerance range

NAS low:

Check the measuring system

a:

Minimum edge separation as a function of the interpolation factor and traversing speed (see point 4.5)

In order to avoid electromagnetic interference, the cable adaptation with a terminal resistor of $R_0 = 120 \Omega$ is necessary. When connecting more than one parallel signal input to an encoder output signal (e.g. linear motors with parallel connection to position controller, speed controller or acceleration controller) ensure that the resulting terminal resistance of these inputs is $R_{0res} \approx 120 \Omega$.

6.16 Online Compensation (Offset and Amplitude Control)

Contamination and mounting errors lead to interferences in the optical scanning of the graduated disk by the scanning head and so to periodic deformations of the sinusoidal counting track signals, which are exemplified as

- Offset deviations
 - Amplitude deviations
 - Amplitude differences between the sine and cosine channels
- and lead to interpolation errors.

Contaminated Graduated Disk

Scanning head signal with contaminated graduated disk before activation of the online compensation.

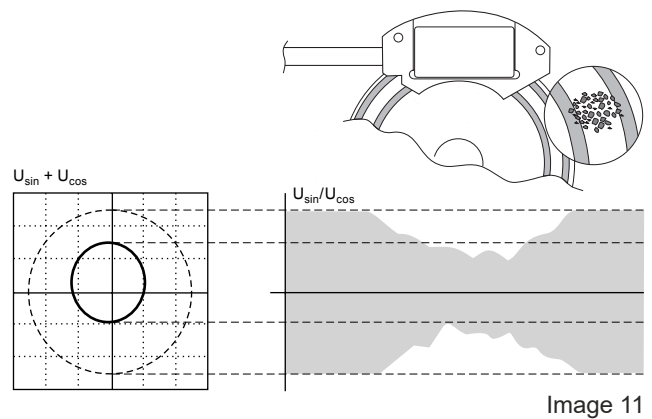

Image 11

Incorrect Mounting

Scanning head signal with faulty mounting before activation of the online compensation.

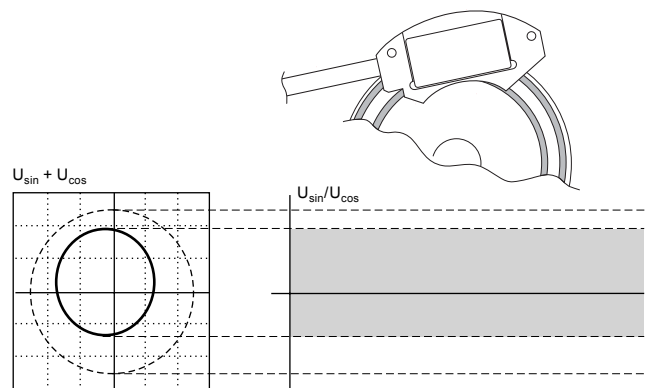

Image 12

Active Online Compensation

Scanning head signal with contaminated graduated disk and/or faulty mounting after activation of the online compensation.

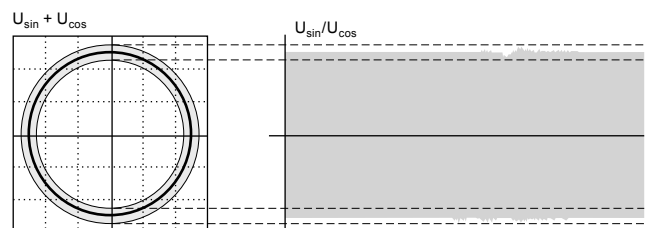

Image 13

Through the online compensation the signals generated by the measuring module are automatically corrected within the sensor without following error over the entire velocity range.

This measure not only increases the accuracy, but also the reliability of the encoder.

7. General Mounting Instructions

7.1 Delivery Contents

Standard

- RIK 4 scanning head (according to the ordered specification)
- Graduated disk (according to the ordered specification)
- Information sheet

Optional

- ADJUSTMENT TOOL
- Extension cable

7.2 Encoder Mounting Position

- The mounting position of the encoder system is arbitrary.
- The operator of the encoder system is responsible for appropriate design measures to protect the scanning head and graduated disk from contamination.
- In any installation position the graduated disk and scanning window of the scanning head should be easily accessible for cleaning. Prevent contamination and foreign elements from having an influence on the operation!
- The counting direction of the encoder is positive (increasing measuring values) if the scanning head is positioned to the graduated disk like shown in the image below.

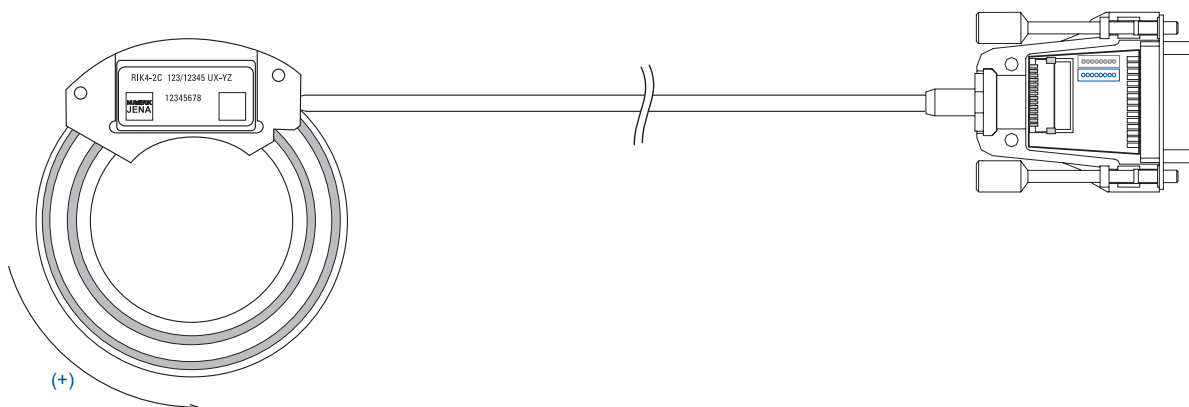

Image 14

7.3 Mounting of the Encoder System

The following shows the assembly of a RIK 4 encoder system. Scanning head and graduated disk must be positioned to each other like shown in the image.

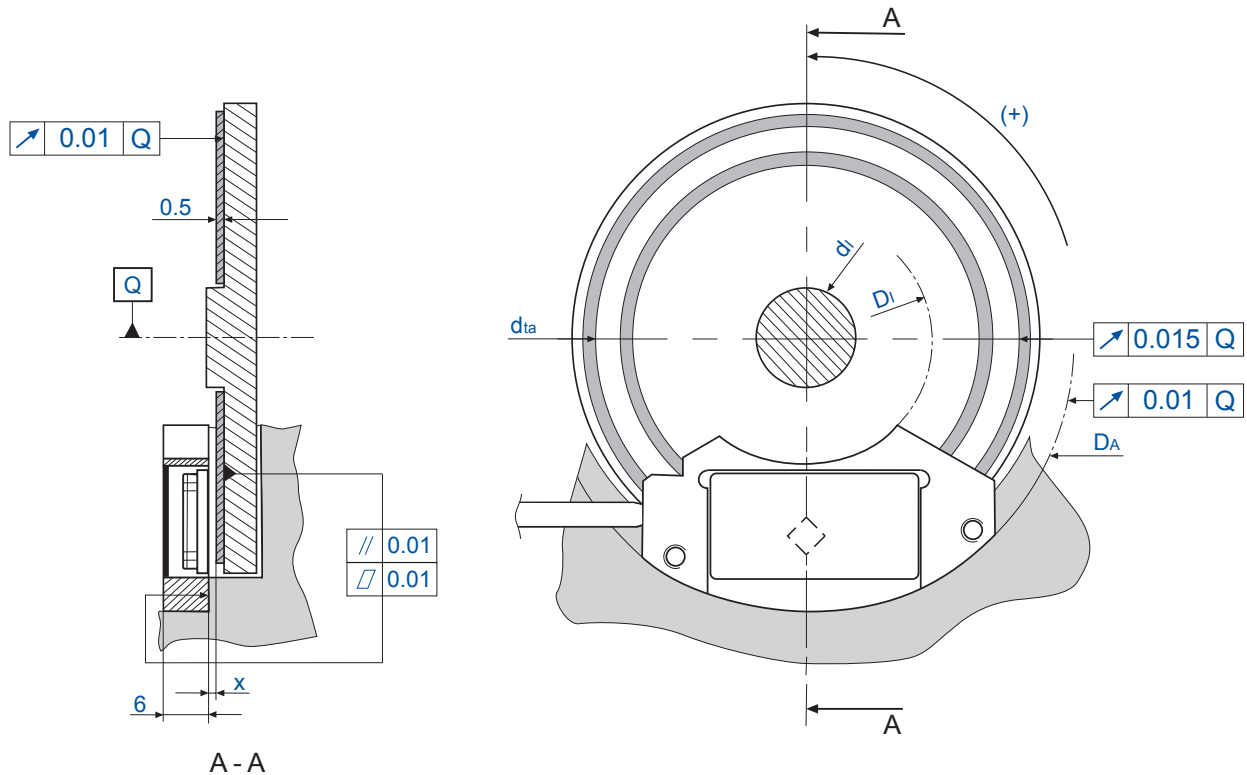

Image 15

- D_A Outside diameter of the stop surface (for scanning head)
- D_I Inside diameter of the stop surface (for scanning head)
- d_i Diameter of the axis
- d_{ta} Outer diameter of the incremental track
- x Working distance (air gap)

Notes on Assembling

The graduated disk must be adjusted regarding the rotational axis Q thus the center diameter of the incremental track d_{ta} observe the eccentricity R.

7.4 Dimensions and Mounting Tolerances

Type	D_A [mm]	D_I [mm]	d_i [mm]	R [mm]	x
RS 19/6/3600	38 ^{H6}	-	-	0.015	0.5 ±0.02
RS 19/9/3600	38 ^{H6}	-	-		0.5 ±0.02
RS 29/16/900	45 ^{H6}	16 _{h6}	-		0.6 ±0.1
RS 29/16/1000	45 ^{H6}	16 _{h6}	-	0.015	0.7 ±0.05
RS 29/16/4500	45 ^{H6}	16 _{h6}	-		0.6 ±0.05
RS 29/20/900	45 ^{H6}	16 _{h6}	-		0.6 ±0.1
RS 39/9.97/3600	55 ^{H6}	26 _{h6}	-		0.4 ±0.05
RS 39/25/1800	55 ^{H6}	26 _{h6}	-		0.5 ±0.1
RS 39/25/2048	55 ^{H6}	26 _{h6}	-	0.015	0.7 ±0.1
RS 39/25/3600	55 ^{H6}	26 _{h6}	-		0.4 ±0.05
RS 39/25/6000	55 ^{H6}	26 _{h6}	-		0.6 ±0.05
RS 39/30/3600	55 ^{H6}	26 _{h6}	-		0.4 ±0.05
RS 45/30/9000	64 ^{H6}	34 _{h6}	-	0.015	0.4 ±0.02
RS 64/48.5/2048	82 ^{H6}	50.8 _{h6}	-		0.8 ±0.05
RS 64/48.5/4096	82 ^{H6}	50.8 _{h6}	-	0.015	0.6 ±0.05
RS 64/48.5/9000	82 ^{H6}	50.8 _{h6}	-		0.9 ±0.05
RS 64/48.5/10000	82 ^{H6}	50.8 _{h6}	-		0.7 ±0.05
RS 92/70/3600	110 ^{H6}	78 _{h6}	-		0.5 ±0.1
RS 92/70/9000	110 ^{H6}	78 _{h6}	-		0.4 ±0.05
RS 92/70/18000	110 ^{H6}	78 _{h6}	-	0.015	0.4 ±0.05
RS 92/76/3600	110 ^{H6}	78 _{h6}	-		0.5 ±0.1
RS 92/80/3600	110 ^{H6}	78 _{h6}	-		0.5 ±0.1

RS 142/120/5400	160 ^{H6}	126 _{h6}	-		0.8 ±0.05
RS 142/120/18000	160 ^{H6}	126 _{h6}	-	0.015	1.2 ±0.05
RS 142/122/5400	160 ^{H6}	126 _{h6}	-		0.8 ±0.05
RS 142/128/18000	160 ^{H6}	126 _{h6}	-		1.2 ±0.05
RS 192/160/24000	210 ^{H6}	180 _{h6}	-	0.015	1.1 ±0.05

(regarding to image 18)

Chart 7

- D_A Outside diameter of the stop surface (for scanning head)
 D_I Inside diameter of the stop surface (for scanning head)
 d_I Diameter of the axis
 R Radial eccentricity - outer diameter of the incremental track
 x Working distance (air gap)

7.5 Mounting of the Graduated Disk

To prevent deformation of the graduated disk by external forces it is recommended to glue the disk to a hub (see image 16). Additionally the mounting and mechanical adjustment to a shaft will be simplified.

The use of a rotary table for mounting will be recommended. For optical vernier adjustment of the graduated disk an adjustment microscope with line marking in the intermediate image plane should be used.

Recommended Mounting Steps:

- 1 Clean all adhesive surfaces by using a soft and lint-free rag. Use a solvent if necessary (e.g. Acetone or Alcohol).
- 2 Center and fix the hub to the rotary table.
- 3 Apply an evenly spreaded adhesive layer to the bottom of the graduated disk. The use of a two-component adhesive, e.g. "Epicol 230004" or an adhesive with similar properties is recommended. Use an appropriate tool, e.g. a dispenser.
- 4 Place the graduated disk on the hub carefully and center it primarily according to the outer diameter of the disk.
- 5 Focus the edge of the graduated disk by using the adjustment microscope. Rotate the graduated disk and determine the location of the minimum deviation **a** and the maximum deviation **b** of the concentricity (see image 17).
- 6 Focus the location of the minimum deviation **a** again and move the graduated disk carefully by half the amount of the difference between deviation **a** and deviation **b**. By doing so the centre of the incremental track and the pivot of the shaft will be aligned.
- 7 Weight down the graduated disk by using an appropriate loading (see image 18) and let the adhesive cure for approximately 1 hour. Please prevent any damage or scratching of the graduated disk by using an appropriate padding between disk and loading.
- 8 Focus the outer diameter of the incremental track of the graduated disk for vernier adjustment. Rotate the disk and determine the location of the minimum deviation **a** and the maximum deviation **b** again.
- 9 Repeat as well as described in step 6. Examine the concentricity and repeat step 6 as often as necessary to reach the required concentricity deviation. Let the adhesive cure (e.g. "Epicol 230004", curing time = 24 hours at room temperature).
- 10 Finally fix and center the hub to the shaft.

ATTENTION: Acetone and Alcohol are inflammable liquids!



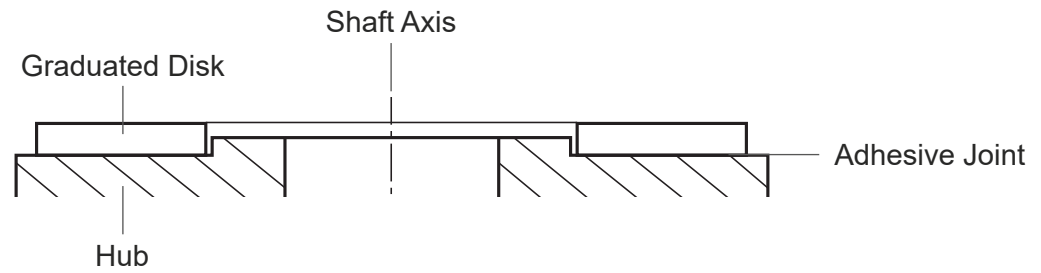

Image 16

Centering of the Graduated Disk with an Adjustment Microscope

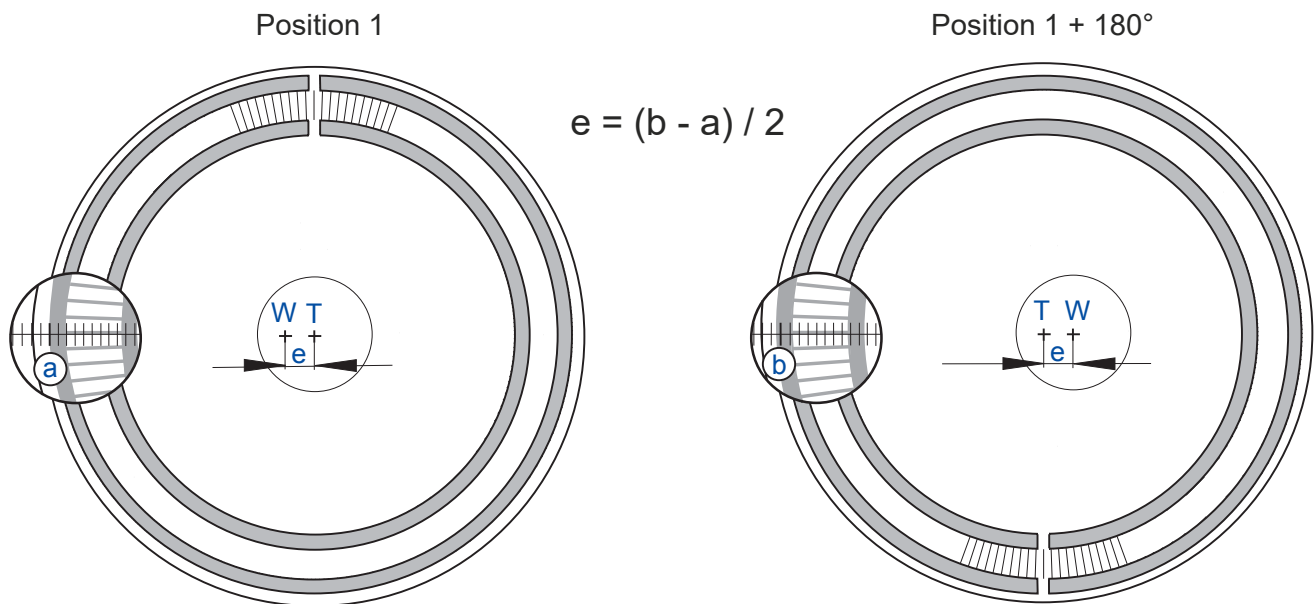

Image 17

- W Center of the axis
- T Center of the incremental track
- e Centering error
- a Minimum deviation
- b Maximum deviation

Mounting Example with Loading After Glueing the Graduated Disk

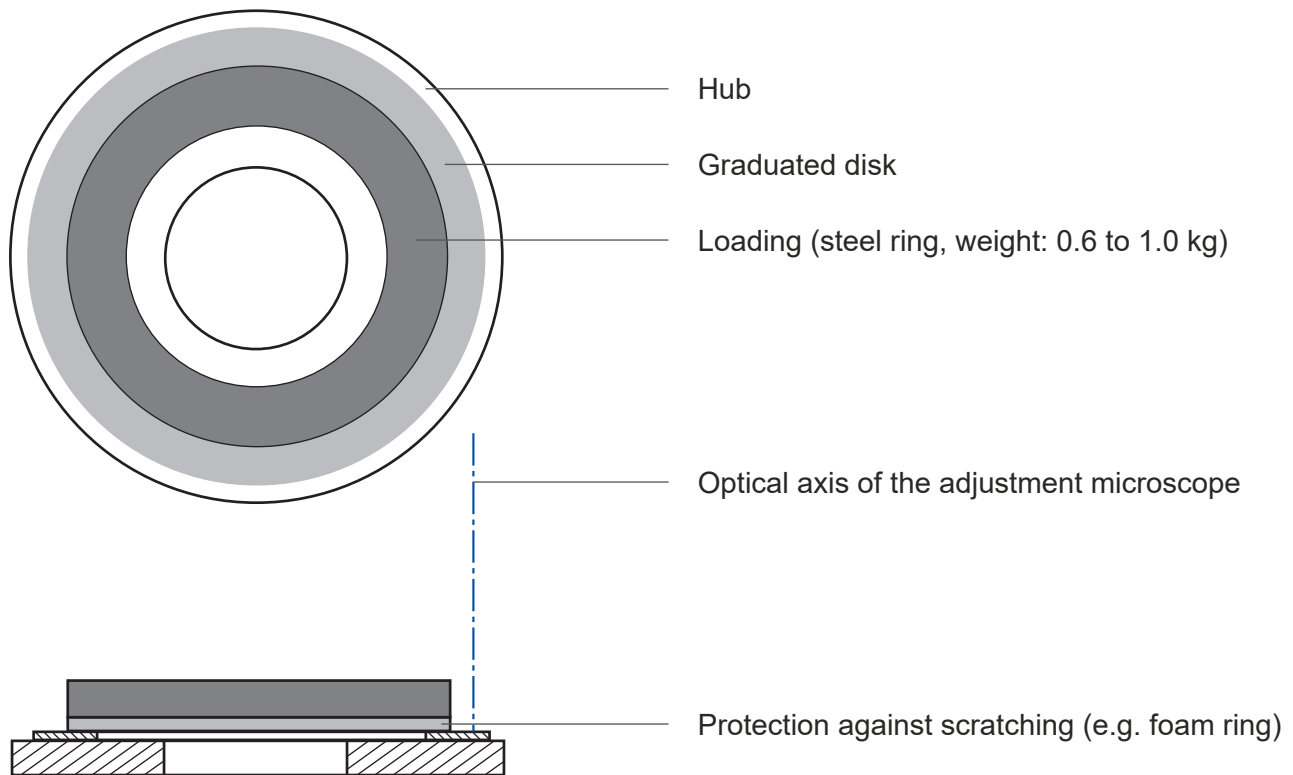

Image 18

Mounting Instructions

- Remove any residue of adhesive which appeared during the mounting procedure from hub and graduated disk immediately.
- Please prevent any damage or scratching of the graduated disk while removing the loading. The surface of the graduated disk is very scratch-sensitive.
- Clean the surfaces by using a soft and lint-free rag. Use a solvent if necessary (e.g. Acetone or Alcohol).
- Please pay attention to the data sheets and notes of the adhesive manufacturer!

ATTENTION: Acetone and Alcohol are inflammable liquids!



Notes

NUMERIK JENA offers the mechanical mounting as well as the adjustment of the graduated disk to a customized hub as a service. The manufacturing of the customized hub can be done by NUMERIK JENA also.

The hub must be designed principally as prescribed in the following image.

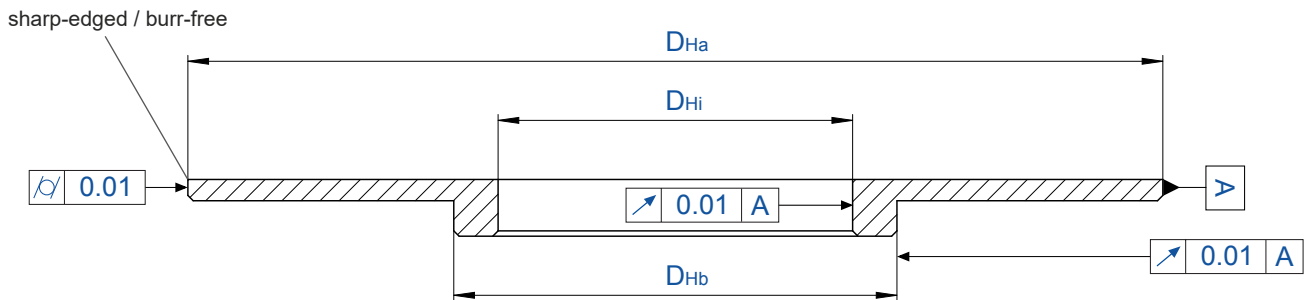

Image 19

- D_{Ha} Outside diameter of the hub
- D_{Hi} Inside diameter of the hub
- D_{Hb} Adjustment diameter of the hub

The inside as well as the outside diameter must be designed as prescribed in the following:

- $D_{Ha} \geq$ Outside diameter of the graduated disk + 1.0 mm
- $D_{Hi} \leq$ Inside diameter of the graduated disk - 1.0 mm

The inside diameter D_{Hi} as well as the adjustment diameter D_{Hb} can be used for the mechanical adjustment on a rotary table. For mounting at NUMERIK JENA the diameter must not exceed or be less than the following values:

- D_{Hi} 26 ... 135 mm
- D_{Hb} 30 ... 140 mm

7.6 Mounting of the Scanning Head

- Clean all mounting surfaces of the scanning head and machine element before mounting. Remove the protection foil from the scanning window of the scanning head.
- Clean the scanning head surfaces carefully by using a soft and lint-free rag. Use a solvent if necessary (e.g. Acetone or Alcohol).
- The mechanical mounting of the scanning head can be done in two ways:

Mounting of a Scanning Head with Through-Holes \varnothing 2.2 mm

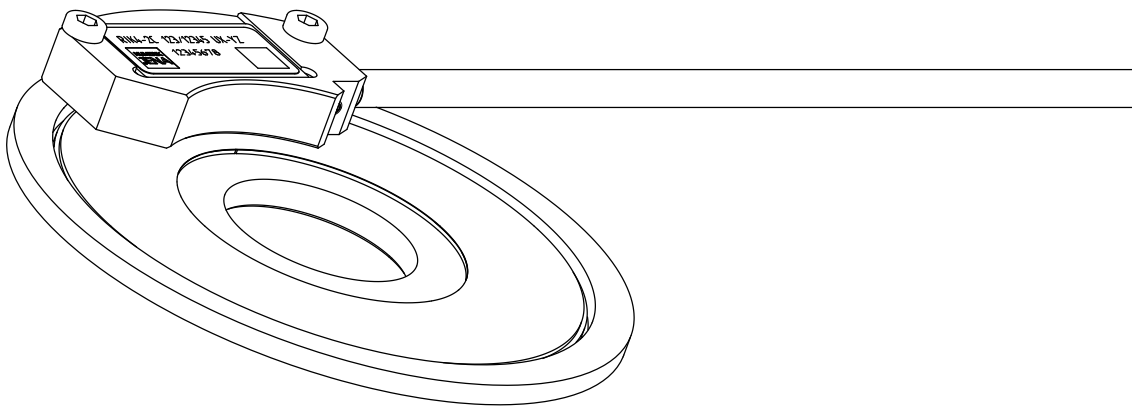

Image 20

Mounting of a Scanning Head with Internal Screw Threads M2.5

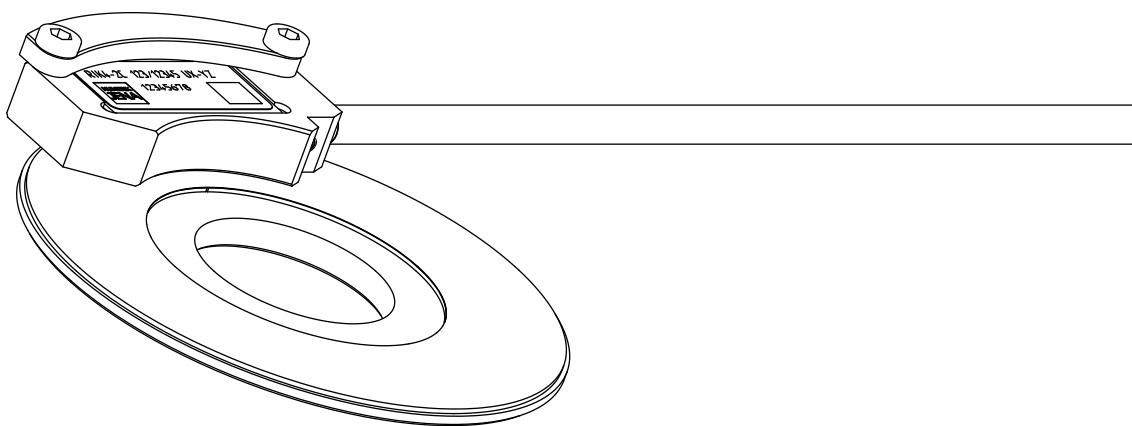

Image 21

- Please pay attention to the indicated mechanical mounting tolerances (see point 7.3 and 7.4).
- Position the encoder cable including a strain relief near the scanning head (see also point 6.9).
- Connect the encoder cable to the evaluation electronics and pay attention to the pin assignment.
The evaluation electronics must be switched off!
- After connecting the encoder cable switch the evaluation electronics on and test the functionality.
- If there are errors in the function or during measurement, please read chapter 10 “Troubleshooting” first. If these information are not helpful for your problem, please contact the technical support of NUMERIK JENA or an authorized subsidiary in your country.

8. Signal Adjustment with ADJUSTMENT TOOL

Before delivery the encoders from NUMERIK JENA will be tested and electronically adjusted under ideal mounting conditions. Furthermore, the sensor modules offer the possibility of an electronic signal adjustment after the mounting into the application. This allows the user optimize the encoder signals regarding to the mechanical mounting conditions (tolerances).

The ADJUSTMENT TOOL and the related EPIFLEX software was designed to simplify and make the signal adjustment more effective.

8.1 Functions of the ADJUSTMENT TOOL

- Representation of the sinusoidal counting signals with amplitude, offset and phase position
- Representation of the position and width of the index signal
- Evaluation of the mechanical mounting conditions
- Automatic signal adjustment and programming of the sensor module
- Electronic readjustment of the amplitude and offset of the sensor signals
- Adjustment of the position and width of the index signal

8.2 Dynamic Offset and Amplitude Control (Online Compensation)

The encoders of NUMERIK JENA are equipped with a dynamic amplitude and offset control (online compensation). The analog diode signals will be corrected to their nominal values in real time. This reduces measuring errors caused by contamination as well as from inaccuracies. The phase position between the sine and cosine signals and the position of the index signal are not influenced by the online compensation.

With help of the EPIFLEX Software the preadjusted nominal values of the online compensation can be influenced.

8.3 Scope of Delivery

- ADJUSTMENT TOOL black box
- Diagnostic cable to connect the measuring system
- USB cable to connect a PC
- USB - D-SUB - adapter cable (15-pin)
- Exchangeable 8-pin plug connectors



Image 22

8.4 EPIFLEX Software

The EPIFLEX software was especially designed for the ADJUSTMENT TOOL. It offers the user versatile possibilities to bring the encoder into service. It also allows the user to display the sensor signals and evaluate them without using an oscilloscope or other expensive hardware. Furthermore it is possible to program respectively optimize the encoder to the existing mounting conditions automatically.

The EPIFLEX software is available for free via download on the NUMERIK JENA website under www.numerikjena.de. Furthermore, one can order the software with an optional USB flash drive.

The EPIFLEX software is suitable for the following operating systems:

- Windows 7 / 8 (32 or 64 bit)

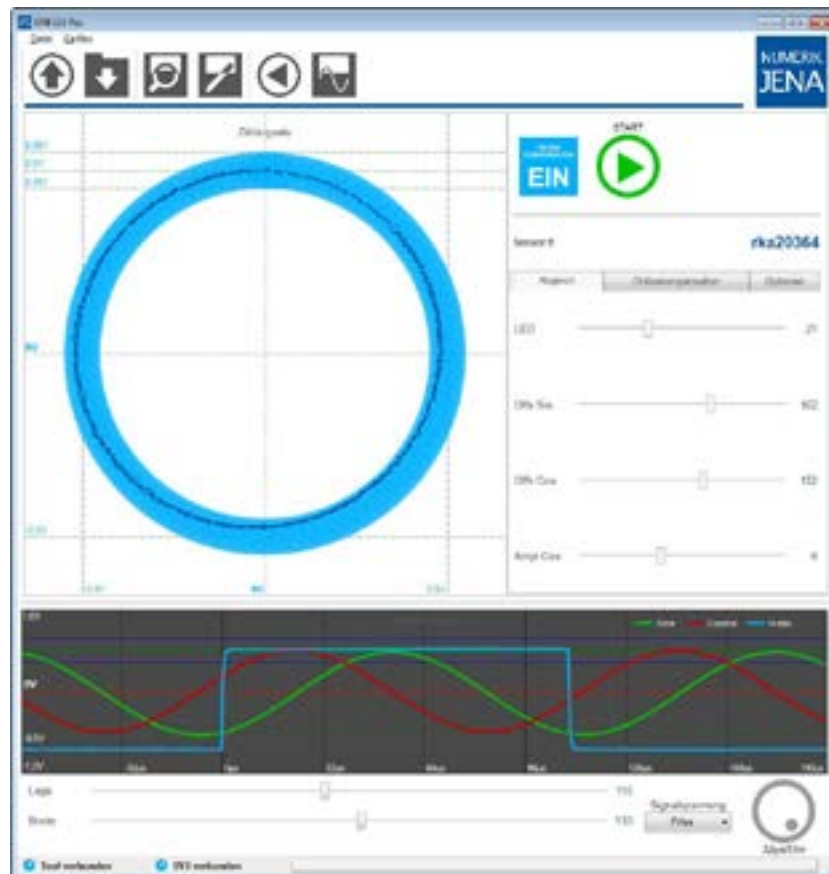

Image 23

Further information about the ADJUSTMENT TOOL and the EPIFLEX software can be found on the NUMERIK JENA website.

9. Cleaning

- Depending on the measuring system's mounting attitude and the ambient conditions, it may be necessary to clean the graduated disk and sensor surface of the scanning head (scanning window for counting and reference track) occasionally.
- If the monitoring signal output by the scanning head is used, the encoder indicates that cleaning is necessary.
- When cleaning the components, ensure that the scanning window and graduated disk are not scratched by any deposited particles!
- Dirt should be removed using a soft brush or oil-free compressed air.
- Use cotton balls or a soft and lint-free rag for cleaning. Use a solvent if necessary (e.g. Acetone or Alcohol).
- Ensure that no solvent seeps under the graduated disk! This could adversely affect the adhesive layer and thereby loosening the graduated disk.
- ATTENTION: Acetone and Alcohol are inflammable liquids!

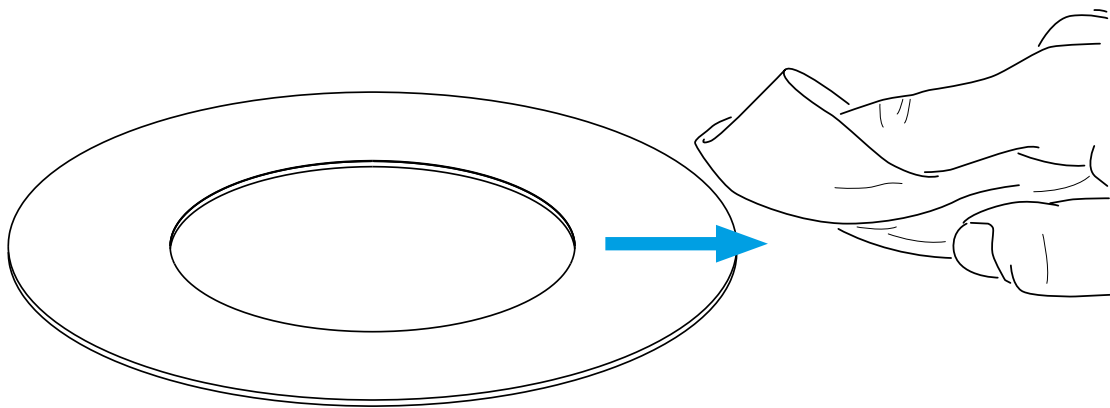

Image 24

10. Troubleshooting

The functions of all scanning heads and accuracy of all scale tapes are tested before the encoders are shipped. However, if troubles or problems should occur, please read the following points in the chart and proceed according to this information.

If this is not helpful, please contact the technical support of NUMERIK JENA GmbH or one of our authorized subsidiaries. You will find respective contact data on the NUMERIK JENA website www.numerikjena.de.

Error	Possible causes	Solution
No measuring signal	No power at the scanning head	<ul style="list-style-type: none"> • Check the status of the evaluation electronics • Check the connection assignment between the encoder and the evaluation electronics
Error message from the evaluation electronics	Following error due to temporary failure of the measuring signal	<ul style="list-style-type: none"> • Check the assignment of the graduated disk to the scanning head • p.r.n. readjust mechanically • Readjust electronically with ADJUSTMENT TOOL*
Rough, loud motor running	Irregular edge separations of the counting signals due to interpolation errors	
Counting error (compared to a standard)	Mounting error	
No reference signal	Mounting error (results in faulty gating of the reference signal and counting signal)	
Reference mark can only be detected from one direction		
Reference mark appears twice		
Not all reference marks are detected		
Failure signal reports (for RS 422)	Mounting error (results in level of the analog signal from the sensor being too low)	Clean the graduated disk (see also chapter 9 „Cleaning“)
	Contamination on the graduated disk (results in level of the analog signal from the sensor being too low)	
	Encoder function operating error	Contact the technical support of NUMERIK JENA

Chart 8

* see also chapter 8

11. Ordering Key

11.1 Scanning Head

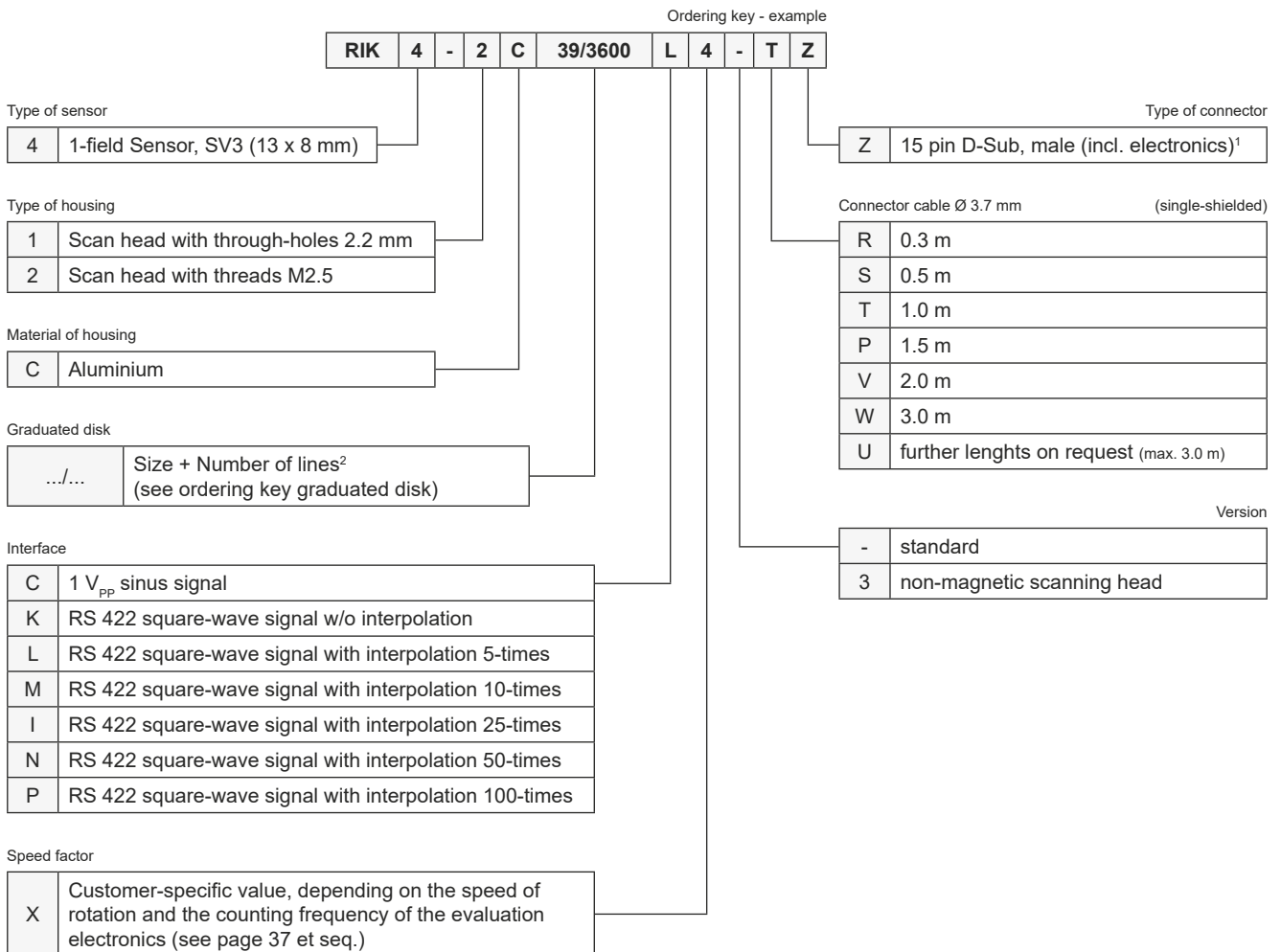

¹ Straight cable outlet

² The chosen combination of size + number of lines in the ordering key scanning head must be identical to the chosen graduated disk.

11.2 Speed Chart for RIK Series

11.2.1 RIK 4 with Op-Amp

The maximum attainable speed of rotation of the encoder is determined by the maximum output frequency of the interpolator and/or the maximum counting frequency of the operator's evaluation electronics (e.g. controller or display).

Please take the suitable values for your application from the following charts and enter it into the corresponding place (for "X") in the ordering key. Pay attention to your chosen interpolation factor and the number of lines of the graduated disk first. If you have found the respective information, please check if your evaluation electronics is able to achieve the needed counting frequency and the maximum speed of rotation. The maximum speed of rotation should not be exceeded.

The maximum scanning frequency of the encoder amounts to 200 kHz standardly, hence the maximum attainable speed of rotation will be derived from that. The op-amp decouples parasitic frequencies and improves the interference immunity of the encoder under unfavorable conditions. The encoders from NUMERIK JENA are available without op-amp also. Thus it is possible to increase the scanning frequency which consequently enables higher speed of rotation.

C Without interpolation factor

Value for X	Number of lines (Z)														Min. counting frequency of the evaluation electronics (in MHz)	
	900	1,000	1,800	2,048	3,600	4,096	4,500	5,400	6,000	9,000	10,000	18,000	24,000	32,000	w/o 4-edge evaluation	with 4-edge evaluation
0	13,333	12,000	6,667	5,859	3,333	2,930	2,667	2,222	2,000	1,333	1,200	667	500	375	0.25	1

L Interpolation factor = 5

Value for X	Number of lines (Z)														Min. counting frequency of the evaluation electronics (in MHz)	
	900	1,000	1,800	2,048	3,600	4,096	4,500	5,400	6,000	9,000	10,000	18,000	24,000	32,000	w/o 4-edge evaluation	with 4-edge evaluation
1	2,222	2,000	1,111	977	556	488	444	370	333	222	200	111	83	63	0.25	1
2	4,444	4,000	2,222	1,953	1,111	977	889	741	667	444	400	222	167	125	0.50	2
Y	6,667	6,000	3,333	2,930	1,667	1,465	1,333	1,111	1,000	667	600	333	250	188	0.75	3
3	8,889	8,000	4,444	3,906	2,222	1,953	1,778	1,481	1,333	889	800	444	333	250	1.00	4
Z	13,333	12,000	6,667	5,859	3,333	2,930	2,667	2,222	2,000	1,333	1,200	667	500	375	1.50	6

M Interpolation factor = 10

Value for X	Number of lines (Z)														Min. counting frequency of the evaluation electronics (in MHz)	
	900	1,000	1,800	2,048	3,600	4,096	4,500	5,400	6,000	9,000	10,000	18,000	24,000	32,000	w/o 4-edge evaluation	with 4-edge evaluation
1	1,111	1,000	556	448	278	244	222	185	167	111	100	56	42	31	0.25	1
2	2,222	2,000	1,111	977	556	488	444	370	333	222	200	111	83	63	0.50	2
Y	3,333	3,000	1,667	1,465	833	732	667	556	500	333	300	167	125	94	0.75	3
3	4,444	4,000	2,222	1,953	1,111	977	889	741	667	444	400	222	167	125	1.00	4
Z	6,667	6,000	3,333	2,930	1,667	1,465	1,333	1,111	1,000	667	600	333	250	188	1.50	6
4	8,889	8,000	4,444	3,906	2,222	1,953	1,778	1,481	1,333	889	800	444	333	250	2.00	8
5	13,333	12,000	6,667	5,859	3,333	2,930	2,667	2,222	2,000	1,333	1,200	667	500	375	3.00	12

I Interpolation factor = 25

Value for X	Number of lines (Z)														Min. counting frequency of the evaluation electronics (in MHz)	
	900	1,000	1,800	2,048	3,600	4,096	4,500	5,400	6,000	9,000	10,000	18,000	24,000	32,000	w/o 4-edge evaluation	with 4-edge evaluation
	[rpm]															
1	444	400	222	195	111	98	89	74	67	44	40	22	17	13	0.25	1
2	889	800	444	391	222	195	178	148	133	89	80	44	33	25	0.50	2
Y	1,333	1,200	667	586	333	293	267	222	200	133	120	67	50	38	0.75	3
3	1,778	1,600	889	781	444	391	356	296	267	178	160	89	67	50	1.00	4
Z	2,667	2,400	1,333	1,172	667	586	533	444	400	267	240	133	100	75	1.50	6
4	3,556	3,200	1,778	1,563	889	781	711	593	533	356	320	178	133	100	2.00	8
5	5,333	4,800	2,667	2,344	1,333	1,172	1,067	889	800	533	480	267	200	150	3.00	12
6	7,111	6,400	3,556	3,125	1,778	1,563	1,422	1,185	1,067	711	640	356	267	200	4.00	16
7	8,889	8,000	4,444	3,906	2,222	1,953	1,778	1,481	1,333	889	800	444	333	250	5.00	20
8	10,667	9,600	5,333	4,688	2,677	2,344	2,133	1,778	1,600	1,067	960	533	400	300	6.00	24

N Interpolation factor = 50

Value for X	Number of lines (Z)														Min. counting frequency of the evaluation electronics (in MHz)	
	900	1,000	1,800	2,048	3,600	4,096	4,500	5,400	6,000	9,000	10,000	18,000	24,000	32,000	w/o 4-edge evaluation	with 4-edge evaluation
	[rpm]															
1	222	200	111	98	56	49	44	37	33	22	20	11	8	6	0.25	1
2	444	400	222	195	111	98	89	74	67	44	40	22	17	13	0.50	2
Y	667	600	333	293	167	146	133	111	100	67	60	33	25	19	0.75	3
3	889	800	444	391	222	195	178	148	133	89	80	44	33	25	1.00	4
Z	1,333	1,200	667	586	333	293	267	222	200	133	120	67	50	38	1.50	6
4	1,778	1,600	889	781	444	391	356	296	267	178	160	89	67	50	2.00	8
5	2,667	2,400	1,333	1,172	667	586	533	444	400	267	240	133	100	75	3.00	12
6	3,556	3,200	1,778	1,563	889	781	711	593	533	356	320	178	133	100	4.00	16
7	4,444	4,000	2,222	1,953	1,111	977	889	741	667	444	400	222	167	125	5.00	20
8	5,333	4,800	2,677	2,344	1,333	1,172	1,067	889	800	533	480	267	200	150	6.00	24

P Interpolation factor = 100

Value for X	Number of lines (Z)														Min. counting frequency of the evaluation electronics (in MHz)	
	900	1,000	1,800	2,048	3,600	4,096	4,500	5,400	6,000	9,000	10,000	18,000	24,000	32,000	w/o 4-edge evaluation	with 4-edge evaluation
	[rpm]															
1	111	100	56	49	28	24	22	19	17	11	10	6	4	3	0.25	1
2	222	200	111	98	56	49	44	37	33	22	20	11	8	6	0.50	2
Y	333	300	167	146	83	73	67	56	50	33	30	17	13	9	0.75	3
3	444	400	222	195	111	98	89	74	67	44	40	22	17	13	1.00	4
Z	667	600	333	293	167	146	133	111	100	67	60	33	25	19	1.50	6
4	889	800	444	391	222	195	178	148	133	89	80	44	33	25	2.00	8
5	1,333	1,200	667	586	333	293	267	222	200	133	120	67	50	38	3.00	12
6	1,778	1,600	889	781	444	391	356	296	267	178	160	89	67	50	4.00	16
7	2,222	2,000	1,111	977	556	488	444	370	333	222	200	111	83	63	5.00	20
8	2,677	2,400	1,333	1,172	667	586	533	444	400	267	240	133	100	75	6.00	24

11.2.2 RIK 4 without Op-Amp

The maximum scanning frequency of the encoder without op-amp amounts to 500 kHz, hence the maximum attainable traversing speed will be derived from that.

C (1 VSS) or K (RS 422) Without interpolation factor

Value for X	Number of lines (Z)														Min. counting frequency of the evaluation electronics (in MHz)	
	900	1,000	1,800	2,048	3,600	4,096	4,500	5,400	6,000	9,000	10,000	18,000	24,000	32,000	w/o 4-edge evaluation	with 4-edge evaluation
	[rpm]															
for C: A	33,333	30,000	16,667	14,648	8,333	7,324	6,667	5,556	5,000	3,333	3,000	1,667	1,250	938	0.5	2
for K: 0																

L Interpolation factor = 5

Value for X	Number of lines (Z)														Min. counting frequency of the evaluation electronics (in MHz)	
	900	1,000	1,800	2,048	3,600	4,096	4,500	5,400	6,000	9,000	10,000	18,000	24,000	32,000	w/o 4-edge evaluation	with 4-edge evaluation
	[rpm]															
B	2,222	2,000	1,111	977	556	488	444	370	333	222	200	111	83	63	0.25	1
C	4,444	4,000	2,222	1,953	1,111	977	889	741	667	444	400	222	167	125	0.50	2
D	6,667	6,000	3,333	2,930	1,667	1,465	1,333	1,111	1,000	667	600	333	250	188	0.75	3
E	8,889	8,000	4,444	3,906	2,222	1,953	1,778	1,481	1,333	889	800	444	333	250	1.00	4
G	13,333	12,000	6,667	5,859	3,333	2,930	2,667	2,222	2,000	1,333	1,200	667	500	375	1.50	6
4	17,778	16,000	8,889	7,813	4,444	3,906	3,556	2,963	2,667	1,778	1,600	889	667	500	2.00	8
5	26,667	24,000	13,333	11,719	6,667	5,859	5,333	4,444	4,000	2,667	2,400	1,333	1,000	750	3.00	12
6	33,333	30,000	16,667	14,648	8,333	7,324	6,667	5,556	5,000	3,333	3,000	1,667	1,250	938	4.00	16

M Interpolation factor = 10

Value for X	Number of lines (Z)														Min. counting frequency of the evaluation electronics (in MHz)	
	900	1,000	1,800	2,048	3,600	4,096	4,500	5,400	6,000	9,000	10,000	18,000	24,000	32,000	w/o 4-edge evaluation	with 4-edge evaluation
	[rpm]															
B	1,111	1,000	556	448	278	244	222	185	167	111	100	56	42	31	0.25	1
C	2,222	2,000	1,111	977	556	488	444	370	333	222	200	111	83	63	0.50	2
D	3,333	3,000	1,667	1,465	833	732	667	556	500	333	300	167	125	94	0.75	3
E	4,444	4,000	2,222	1,953	1,111	977	889	741	667	444	400	222	167	125	1.00	4
G	6,667	6,000	3,333	2,930	1,667	1,465	1,333	1,111	1,000	667	600	333	250	188	1.50	6
R	8,889	8,000	4,444	3,906	2,222	1,953	1,778	1,481	1,333	889	800	444	333	250	2.00	8
S	13,333	12,000	6,667	5,859	3,333	2,930	2,667	2,222	2,000	1,333	1,200	667	500	375	3.00	12
6	17,778	16,000	8,889	7,813	4,444	3,906	3,556	2,963	2,667	1,778	1,600	889	667	500	4.00	16
7	22,222	20,000	11,111	9,766	5,556	4,883	4,444	3,704	3,333	2,222	2,000	1,111	833	625	5.00	20
8	26,667	24,000	13,333	11,719	6,667	5,859	5,333	4,444	4,000	2,667	2,400	1,333	1,000	750	6.00	24

I Interpolation factor = 25

Value for X	Number of lines (Z)														Min. counting frequency of the evaluation electronics (in MHz)	
	900	1,000	1,800	2,048	3,600	4,096	4,500	5,400	6,000	9,000	10,000	18,000	24,000	32,000	w/o 4-edge evaluation	with 4-edge evaluation
	[rpm]															
B	444	400	222	195	111	98	89	74	67	44	40	22	17	13	0.25	1
C	889	800	444	391	222	195	178	148	133	89	80	44	33	25	0.50	2
D	1,333	1,200	667	586	333	293	267	222	200	133	120	67	50	38	0.75	3
E	1,778	1,600	889	781	444	391	356	296	267	178	160	89	67	50	1.00	4
G	2,667	2,400	1,333	1,172	667	586	533	444	400	267	240	133	100	75	1.50	6
R	3,556	3,200	1,778	1,563	889	781	711	593	533	356	320	178	133	100	2.00	8
S	5,333	4,800	2,667	2,344	1,333	1,172	1,067	889	800	533	480	267	200	150	3.00	12
T	7,111	6,400	3,556	3,125	1,778	1,563	1,422	1,185	1,067	711	640	356	267	200	4.00	16
U	8,889	8,000	4,444	3,906	2,222	1,953	1,778	1,481	1,333	889	800	444	333	250	5.00	20
V	10,667	9,600	5,333	4,688	2,677	2,344	2,133	1,778	1,600	1,067	960	533	400	300	6.00	24

N Interpolation factor = 50

Value for X	Number of lines (Z)														Min. counting frequency of the evaluation electronics (in MHz)	
	900	1,000	1,800	2,048	3,600	4,096	4,500	5,400	6,000	9,000	10,000	18,000	24,000	32,000	w/o 4-edge evaluation	with 4-edge evaluation
	[rpm]															
B	222	200	111	98	56	49	44	37	33	22	20	11	8	6	0.25	1
C	444	400	222	195	111	98	89	74	67	44	40	22	17	13	0.50	2
D	667	600	333	293	167	146	133	111	100	67	60	33	25	19	0.75	3
E	889	800	444	391	222	195	178	148	133	89	80	44	33	25	1.00	4
G	1,333	1,200	667	586	333	293	267	222	200	133	120	67	50	38	1.50	6
R	1,778	1,600	889	781	444	391	356	296	267	178	160	89	67	50	2.00	8
S	2,667	2,400	1,333	1,172	667	586	533	444	400	267	240	133	100	75	3.00	12
T	3,556	3,200	1,778	1,563	889	781	711	593	533	356	320	178	133	100	4.00	16
U	4,444	4,000	2,222	1,953	1,111	977	889	741	667	444	400	222	167	125	5.00	20
V	5,333	4,800	2,677	2,344	1,333	1,172	1,067	889	800	533	480	267	200	150	6.00	24

P Interpolation factor = 100

Value for X	Number of lines (Z)														Min. counting frequency of the evaluation electronics (in MHz)	
	900	1,000	1,800	2,048	3,600	4,096	4,500	5,400	6,000	9,000	10,000	18,000	24,000	32,000	w/o 4-edge evaluation	with 4-edge evaluation
	[rpm]															
B	111	100	56	49	28	24	22	19	17	11	10	6	4	3	0.25	1
C	222	200	111	98	56	49	44	37	33	22	20	11	8	6	0.50	2
D	333	300	167	146	83	73	67	56	50	33	30	17	13	9	0.75	3
E	444	400	222	195	111	98	89	74	67	44	40	22	17	13	1.00	4
G	667	600	333	293	167	146	133	111	100	67	60	33	25	19	1.50	6
R	889	800	444	391	222	195	178	148	133	89	80	44	33	25	2.00	8
S	1,333	1,200	667	586	333	293	267	222	200	133	120	67	50	38	3.00	12
T	1,778	1,600	889	781	444	391	356	296	267	178	160	89	67	50	4.00	16
U	2,222	2,000	1,111	977	556	488	444	370	333	222	200	111	83	63	5.00	20
V	2,677	2,400	1,333	1,172	667	586	533	444	400	267	240	133	100	75	6.00	24

11.3 Graduated Disk

Ordering key - example

RS 39/25/3600 GL UX B

RS Graduated disk

Centre Ø
of counting track d_c Inside-Ø
graduated disk d_i Number of lines Z

13	5.5	2,048
13	6	2,048
19	6	3,600
19	9	3,600
29	16	900
29	16	1,000
29	16	4,500
29	20	900
39	9.97	3,600
39	10	2,048
39	25	1,800
39	25	2,048
39	25	3,600
39	25	6,000
39	30	3,600
45	30	9,000
64	48.5	2,048
64	48.5	4,096
64	48.5	9,000
64	48.5	10,000
92	70	3,600
92	70	9,000
92	70	18,000
92	76	3,600
92	80	3,600
142	120	5,400
142	120	18,000
142	122	5,400
142	128	18,000
192	160	24,000

(other sizes on request)

Supply

	Without supply (please leave this blank)
B	You want to supply your own hub to glue on the graduated disk.

Service

	Without glueing (please leave this blank)
UX	We will glue the graduated disk to your given hub. On request we are able to manufacture the corresponding hub for you.

Material

	Aluminium - graduated disk (please leave this blank)
GL	Glass - graduated disk (on request only)

11.4 ADJUSTMENT TOOL

Name	Scope of delivery / Description	Order-no.
ADJUSTMENT TOOL	<ul style="list-style-type: none"> ADJUSTMENT TOOL black box Diagnostic cable to connect the measuring system USB cable to connect a PC USB - D-SUB - adapter cable (15-pin) Exchangeable 8-pin plug connectors 	344220-33

Optional Single Components

Name	Description	Order-no.
EPIFLEX software - USB flash drive	External flash drive with saved EPIFLEX software	686802-02
USB - D-SUB - adapter cable (15-pin)	to supply the measuring system with voltage via PC	341693-0M
8-pin plug connector	to connect the diagnostic cable to the diagnostic socket	348958-01



USB - D-SUB - adapter cable (15-pin)

Image 25

Required components (not included):

- PC with OS Windows 7 / 8 (32 or 64 bit)



NUMERIK JENA GmbH

Im Semmicht 4
07751 Jena
Germany

Phone: +49 3641 4728-0

Fax: +49 3641 4728-202

E-Mail: info@numerikjena.de

www.numerikjena.de

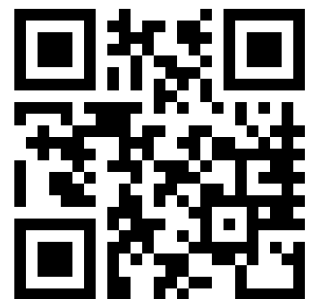

Version 04 2023

© & © NUMERIK JENA GmbH