

Index

| | | |
|-----------|--|-----------|
| 1. | Features and Applications | 4 |
| 2. | Safety | 5 |
| 2.1 | General Information | 5 |
| 2.2 | Notes on Legal Requirements | 6 |
| 2.3 | Environmental Protection and Disposal | 6 |
| 2.4 | Notes on Transport, Storage and Handling | 7 |
| 2.5 | Notes on Operation | 8 |
| 2.6 | Notes on Maintenance | 8 |
| 3. | Setup of the Rotary Encoder | 9 |
| 4. | Graduated Disks | 9 |
| 4.1 | Graduated Disks - Types | 10 |
| 5. | Scanning Head | 11 |
| 6. | Technical Data | 12 |
| 6.1 | Resolution and Accuracy (Definition) | 12 |
| 6.2 | Resolution | 12 |
| 6.3 | Accuracy | 12 |
| 6.4 | Mechanical Data | 13 |
| 6.5 | Calculation of the Attainable Speed of Rotation | 13 |
| 6.6 | Electrical Data | 14 |
| 6.7 | Switch-On Behaviour | 14 |
| 6.8 | Ambient Conditions | 15 |
| 6.9 | Cable | 15 |
| 6.10 | Connector | 15 |
| 6.11 | PIN Assignment | 16 |
| 6.12 | Electromagnetic Compatibility (EMC) | 17 |
| 6.13 | Shielding Concepts | 18 |
| 6.14 | Voltage Output $1 V_{PP}$ | 19 |
| 6.15 | Square-Wave Output RS-422 | 20 |
| 6.16 | Online Compensation (Offset and Amplitude Control) | 21 |
| 7. | General Mounting Instructions | 22 |
| 7.1 | Delivery Contents | 22 |
| 7.2 | Encoder Mounting Position | 22 |
| 7.3 | Mounting of the Encoder System | 23 |
| 7.4 | Dimensions and Mounting Tolerances | 24 |
| 7.5 | Mounting of the Graduated Disk | 25 |
| 7.6 | Mounting of the Scanning Head | 29 |

| | | |
|------------|--|-----------|
| 8. | Signal Adjustment with ADJUSTMENT TOOL | 31 |
| 8.1 | Functions of the ADJUSTMENT TOOL | 31 |
| 8.2 | Dynamic Offset and Amplitude Control (Online Compensation) | 31 |
| 8.3 | Scope of Delivery | 31 |
| 8.4 | EPIFLEX Software | 32 |
| 9. | Cleaning | 33 |
| 10. | Troubleshooting | 34 |
| 11. | Ordering Key | 35 |
| 11.1 | Scanning Head | 35 |
| 11.2 | Speed Chart for RIK Series | 36 |
| 11.2.1 | RIK 4 with Op-Amp | 36 |
| 11.2.2 | RIK 4 without Op-Amp | 38 |
| 11.3 | Graduated Disk | 40 |
| 11.4 | ADJUSTMENT TOOL | 41 |

1. Features and Applications

Position encoders in drive systems have to meet high and controversial demands. The demands opposing each other are high accuracy and resolution on the one hand and low mass, small dimensions and high measuring speed on the other hand.

- The concentration of multiple axes in rotation in very tight spaces, such as in semiconductor-producing machines, requires the miniaturization of the drives, bearings and encoders.
- High machining speeds and therefore high accelerations make low masses of the components in motion essential.

The optical RIK 4 incremental encoders from NUMERIK JENA are equipped with features which are supposed to fulfill these high requirements in an ideal way.

- Due to an interpolation circuitry which is integrated in a 15-pin D-sub connector, a resolutions down to 0.135 arc seconds is possible without any additional electronics.
- The permissible speed of rotation for a sinusoidal signal output amounts up to 22,000 rpm.
- The short-range position errors (interpolation errors) were significantly reduced by introducing an electronic compensation of amplitude and offset deviations of the coarse signals. This compensation functions without following error in all velocity ranges.

Additional features:

- Compact size and large mounting tolerances
- Low mass moment of inertia of the graduated disk
- High measuring speed
- Online compensation (dynamic offset and amplitude control)
- Optional signal interpolation up to 100-times in the connector
- Possibility of electronic signal adjustment (signal optimization after mounting)

Applications:

- Automation technology
- Rotary axes
- Drive systems, especially direct drives and torque motors
- Instruments and machines used in semiconductor industry
- Robot and handling technology
- High-precision engineering
- Metrology
- Medical technology

2. Safety

2.1 General Information

- Make sure to familiarize yourself thoroughly with the contents of these installation instructions before installing and starting up the encoder!
- Please contact the support of NUMERIK JENA GmbH or an authorized representation for further information. Please visit the NUMERIK JENA website to get the contact information.
- NUMERIK JENA GmbH is not liable for damages caused by unauthorized handling of the encoders. Any unauthorized handling leads to forfeiture of all warranty claims.
- The encoders are guaranteed to function if the mounting and operating conditions are maintained as stated in these mounting instructions.
- Make sure to follow the right sequence of the mounting steps during mounting.
- NUMERIK JENA GmbH does not assume any liability for any damages or operating errors caused by incorrect installation or operation.
- The stated tolerances must be maintained in order to achieve the accuracies listed in the specifications!
- If the machine tolerances exceed the tolerances stated in the mounting instructions, errors can occur in both the operation and during measuring. NUMERIK JENA GmbH assumes no liability for this.
- Please refer to the operating manuals and safety instructions included with the devices to ensure the reliable operation of the encoder systems, especially pertaining to:
 - Auxiliary electronic units
 - Counters
 - Displays
 - Controllers
 - Encoders
 - Base mechanical devices (machine tools)
- Connect NUMERIK JENA encoders only to subsequent electronics whose power supply is generated from PELV systems (EN 50178).
- Please pay attention to the safety instructions and warning symbols!



Danger to the device or to the function of the device!



Pull the plug!



Highly inflammable!

2.2 Notes on Legal Requirements

- The NUMERIK JENA encoders conform to EC standards and carry the CE mark.
- NUMERIK JENA encoders fulfill the requirements of the (German) Product Safety Act (ProdSG) from November 8th, 2011.
- NUMERIK JENA encoders fulfill the requirements of standard IEC 61010-1 only if the power is supplied from a secondary circuit with current limitation as per IEC 61010 (3rd Ed.), Section 9.4 or with power limitation as per IEC 62368-1 (2nd Ed.), section 6.2.2.5 PS2 or from a Class 2 secondary circuit as specified in UL1310.*
- This user manual supersedes all previous editions, which thereby become invalid. The basis for ordering from NUMERIK JENA is always the user manual edition valid when the contract is made.
- Standards (ISO, EN, etc.) apply only where explicitly stated in the user manual.
- NUMERIK JENA has tested its products to ensure the use of non-hazardous materials in accordance with the European Directives 2011/65/EU (RoHS). The EU Declaration of Conformity can be requested at the following web address:

<https://www.numerikjena.com/numerikjena/contact/>

2.3 Environmental Protection and Disposal

Environmental damage due to incorrect disposal of the product, accessories or peripherals!

- Do not dispose in domestic waste.
- Dispose only by authorized collection points. Electrical waste and electronic components are subject to special-waste regulations.
- Observe the applicable country-specific regulations.

More detailed information on legal regulations can be obtained from competent authorities.

* In place of IEC 61010-1 (3rdEd.), Section 9.4, the corresponding sections of standards DIN EN 61010-1, EN61010-1, UL 61010-1 and CAN/CSA-C22.2 No. 61010-1 can be applied and in place of IEC 62368-1 (2nd Ed.), section 6.2.2.5 PS2 the corresponding sections of standards DIN EN62368-1, EN62368-1, UL62368-1, CAN/CSA-C22.2 No. 62368-1 can be applied.

2.4 Notes on Transport, Storage and Handling



- Please use the original packaging for transportation and storage only!
- After receiving the measuring system please check the packaging and the seal for damages first! Once opened, scratches or contaminations on the graduated disk cannot be complained anymore.
- Handle the graduated disk carefully! Its surface is sensitive to scratching.
- Small surface errors evident at the time of shipping are due to the production process. These errors are no indication for a quality defect and do not affect the encoder's functionality.
- Handle the aluminum disk carefully please and protect it especially against mechanical deformation. Unevenness of the disk influences the correct operation of the encoder.



Image 1

2.5 Notes on Operation



- Do not connect or disconnect plugs if the power is on!
- Only operate the encoder with the supply voltage stated in this product data sheet.
- Connect NUMERIK JENA encoders only to subsequent electronics whose power supply is generated from PELV systems (EN 50178).
- Comply with applicable PIN assignment if auxiliary electronic units are connected (e.g. controller or display)!
- Integrate exposed encoders in instruments, devices or machines in such a way that these are protected against contamination.
- Protect the graduated disk against mechanical damage.
- Protect the scanning head against shock, impact and humidity.

2.6 Notes on Maintenance



- The encoder requires no maintenance whatsoever, but must be cleaned occasionally, depending on the ambient conditions.
- Modifications and repairs of the encoder may only be carried out by NUMERIK JENA GmbH or appropriately authorized persons.
- NUMERIK JENA GmbH is not liable for damages caused by unauthorized handling of the encoder. All warranty claims are forfeited by unauthorized handling.
- Exposed measuring systems are sensitive to contamination, especially the disk surface and the scanning windows for the counting and reference tracks on the scanning head.
- Particularly critical are rough and irregular contamination and deposits (e.g. oil, grease or water).
- The user has to protect the encoder from contamination by way of appropriate design measures.
- **When cleaning the encoder, ensure that no solvent flows under the graduated disk!**
- **When cleaning the components, ensure that the scanning window and graduated disk are not scratched by any deposited particles!**
- **Please also pay attention to the notes in chapter 9 „Cleaning“.**

3. Setup of the Rotary Encoder

The RIK 4 encoder consists of the following components:

- Scanning head with integrated EPIFLEX sensor module
- Graduated disk with counting track and index
- 15-pin D-Sub connector with integrated electronics

Scanning head and connector are connected by a round cable. The grating on the disk will be detected by the scanning head opto-electronically.

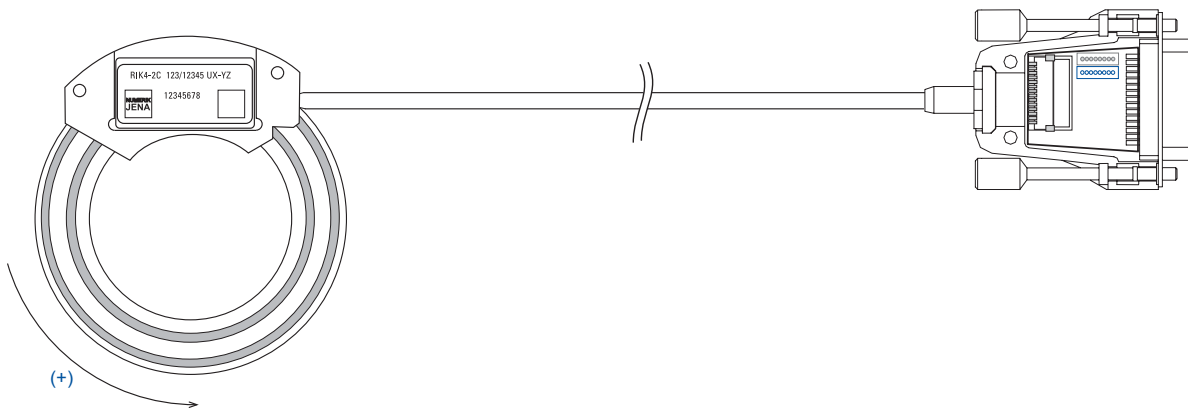

Image 2

4. Graduated Disks

The graduated disks from NUMERIK JENA are available in different sizes and versions. Hereto we have a big selection of obtainable graduated disks in supply but on request we also manufacture at customer's option.

Our graduated disks are made of an aluminium alloy. They are also available in glass on request.

thickness depends
to the material
for Aluminium = 0.5 mm
for glass on request

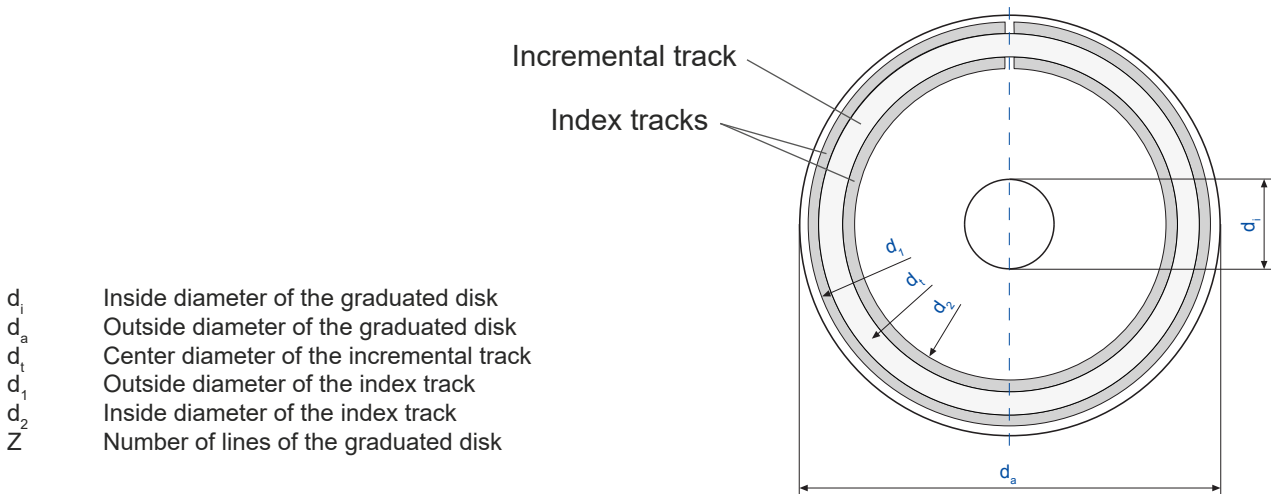

Image 3

4.1 Graduated Disks - Types

| Type | d_i [mm] | d_a [mm] | d_t [mm] | d_1 [mm] | d_2 [mm] | d_L [mm] | d [mm] | Z |
|------------------|------------|--|------------|------------|------------|------------|----------|--------|
| RS 19/6/3600 | 6 + 0.1 | 26 $\begin{smallmatrix} -0.2 \\ -0.5 \end{smallmatrix}$ | 19 | 24 | 14 | - | - | 3,600 |
| RS 19/9/3600 | 9 + 0.1 | 26 $\begin{smallmatrix} -0.2 \\ -0.5 \end{smallmatrix}$ | 19 | 24 | 14 | - | - | 3,600 |
| RS 29/16/900 | 16 + 0.1 | 36 $\begin{smallmatrix} -0.2 \\ -0.5 \end{smallmatrix}$ | 29 | 34 | 24 | - | - | 900 |
| RS 29/16/1000 | 16 + 0.1 | 36 $\begin{smallmatrix} -0.2 \\ -0.5 \end{smallmatrix}$ | 29 | 34 | 24 | - | - | 1,000 |
| RS 29/16/4500 | 16 + 0.1 | 36 $\begin{smallmatrix} -0.2 \\ -0.5 \end{smallmatrix}$ | 29 | 34 | 24 | - | - | 4,500 |
| RS 29/20/900 | 20 + 0.1 | 36 $\begin{smallmatrix} -0.2 \\ -0.5 \end{smallmatrix}$ | 29 | 34 | 24 | - | - | 900 |
| RS 39/9,97/3600 | 25 + 0.1 | 46 $\begin{smallmatrix} -0.2 \\ -0.5 \end{smallmatrix}$ | 39 | 44 | 34 | - | - | 3,600 |
| RS 39/25/1800 | 25 + 0.1 | 46 $\begin{smallmatrix} -0.2 \\ -0.5 \end{smallmatrix}$ | 39 | 44 | 34 | - | - | 1,800 |
| RS 39/25/2048 | 25 + 0.1 | 46 $\begin{smallmatrix} -0.2 \\ -0.5 \end{smallmatrix}$ | 39 | 44 | 34 | - | - | 2,048 |
| RS 39/25/3600 | 25 + 0.1 | 46 $\begin{smallmatrix} -0.2 \\ -0.5 \end{smallmatrix}$ | 39 | 44 | 34 | - | - | 3,600 |
| RS 39/25/6000 | 25 + 0.1 | 46 $\begin{smallmatrix} -0.2 \\ -0.5 \end{smallmatrix}$ | 39 | 44 | 34 | - | - | 6,000 |
| RS 39/30/3600 | 30 + 0.1 | 46 $\begin{smallmatrix} -0.2 \\ -0.5 \end{smallmatrix}$ | 39 | 44 | 34 | - | - | 3,600 |
| RS 45/30/9000 | 30 + 0.1 | 54 $\begin{smallmatrix} -0.2 \\ -0.5 \end{smallmatrix}$ | 45 | 50 | 40 | - | - | 9,000 |
| RS 64/48,5/2048 | 48,5 + 0.1 | 71 $\begin{smallmatrix} -0.2 \\ -0.5 \end{smallmatrix}$ | 64 | 69 | 59 | - | - | 2,048 |
| RS 64/48,5/4096 | 48,5 + 0.1 | 71 $\begin{smallmatrix} -0.2 \\ -0.5 \end{smallmatrix}$ | 64 | 69 | 59 | - | - | 4,096 |
| RS 64/48,5/9000 | 48,5 + 0.1 | 71 $\begin{smallmatrix} -0.2 \\ -0.5 \end{smallmatrix}$ | 64 | 69 | 59 | - | - | 9,000 |
| RS 64/48,5/10000 | 48,5 + 0.1 | 71 $\begin{smallmatrix} -0.2 \\ -0.5 \end{smallmatrix}$ | 64 | 69 | 59 | - | - | 10,000 |
| RS 92/70/3600 | 70 + 0.1 | 100 $\begin{smallmatrix} -0.2 \\ -0.5 \end{smallmatrix}$ | 92 | 97 | 87 | - | - | 3,600 |
| RS 92/70/9000 | 70 + 0.1 | 100 $\begin{smallmatrix} -0.2 \\ -0.5 \end{smallmatrix}$ | 92 | 97 | 87 | - | - | 9,000 |
| RS 92/70/18000 | 70 + 0.1 | 100 $\begin{smallmatrix} -0.2 \\ -0.5 \end{smallmatrix}$ | 92 | 97 | 87 | - | - | 18,000 |
| RS 92/76/3600 | 76 + 0.1 | 100 $\begin{smallmatrix} -0.2 \\ -0.5 \end{smallmatrix}$ | 92 | 97 | 87 | - | - | 3,600 |
| RS 92/80/3600 | 80 + 0.1 | 105 $\begin{smallmatrix} -0.2 \\ -0.5 \end{smallmatrix}$ | 92 | 97 | 87 | - | - | 3,600 |
| RS 142/120/5400 | 120 + 0.2 | 150 $\begin{smallmatrix} -0.2 \\ -0.5 \end{smallmatrix}$ | 142 | 147 | 137 | - | - | 5,400 |
| RS 142/120/18000 | 120 + 0.2 | 150 $\begin{smallmatrix} -0.2 \\ -0.5 \end{smallmatrix}$ | 142 | 147 | 137 | - | - | 18,000 |
| RS 142/122/5400 | 122 + 0.2 | 150 $\begin{smallmatrix} -0.2 \\ -0.5 \end{smallmatrix}$ | 142 | 147 | 137 | - | - | 5,400 |
| RS 142/128/18000 | 128 + 0.2 | 150 $\begin{smallmatrix} -0.2 \\ -0.5 \end{smallmatrix}$ | 142 | 147 | 137 | - | - | 18,000 |
| RS 192/160/24000 | 160 + 0.2 | 199 $\begin{smallmatrix} -0.2 \\ -0.5 \end{smallmatrix}$ | 192 | 197 | 187 | - | - | 24,000 |

(other sizes on request)

Chart 1

5. Scanning Head

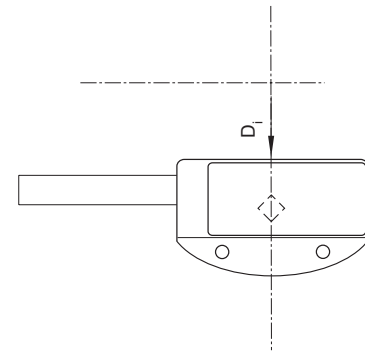
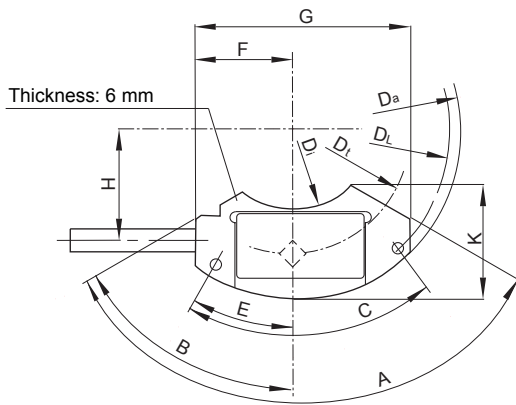

Example: RIK 4-2C 19/3600...
(with stop surface on outside diameter only)

Image 4

| Type | D_a [mm] | D_t [mm] | D_i [mm] | D_L [mm] | A | B | C | E | F | G | H | K |
|------|-------------------|------------|--------------------|------------|------|-----|-----|-----|----|----|------|------|
| 19 | 38 _{h6} | 19 | 4* | 34 ±0.1 | - | - | 44° | 22° | 12 | 24 | 8 | 15.0 |
| 29 | 45 _{h6} | 29 | 16 ^{H6} | 41 ±0.1 | 120° | 60° | 82° | 34° | 16 | 34 | 13 | 18.8 |
| 39 | 55 _{h6} | 39 | 26 ^{H6} | 51 ±0.1 | 120° | 60° | 70° | 30° | 16 | 35 | 18 | 18.6 |
| 45 | 64 _{h6} | 45 | 34 ^{H6} | 60 ±0.1 | 120° | 60° | 56° | 28° | 16 | 32 | 20.8 | 18.0 |
| 64 | 82 _{h6} | 64 | 50.8 ^{H6} | 77 ±0.1 | 90° | 45° | 44° | 22° | 18 | 36 | 30 | 19.2 |
| 92 | 110 _{h6} | 92 | 78 ^{H6} | 106 ±0.1 | 90° | 45° | 34° | 17° | 18 | 36 | 44 | 18.5 |
| 142 | 160 _{h6} | 142 | 126 ^{H6} | 156 ±0.1 | 90° | 45° | 22° | 11° | 18 | 36 | 69 | 18.7 |
| 192 | 210 _{h6} | 192 | 180 ^{H6} | 206 ±0.1 | - | - | 10° | 5° | 13 | 26 | 94 | 15.8 |

* distance to the center, do not use as datum dimension

Chart 2

- D_a Outside diameter of the scanning head
- D_i Inside diameter of the scanning head
- D_t Center diameter of the counting track
- D_L Hole spacing of borings for mounting screws

6. Technical Data

6.1 Resolution and Accuracy (Definition)

Basically one has to differentiate between the resolution and the accuracy of a measuring system. The two parameters are not directly interdependent and may differ from each other.

6.2 Resolution

Resolution "A" is defined as the smallest angular value that is still detected by the evaluating electronics (display, control) when the graduated disk is turned relative to the scanning head. The resolution can be calculated using the following formula:

$$A = Z \cdot i \cdot N \quad [\text{Increments/Revolution}]$$

$$A = \frac{360^\circ}{Z \cdot i \cdot N} \quad [\text{Degrees}]$$

| | |
|---|--|
| Z | Number of lines (graduated disk) |
| i | Interpolation factor of the evaluation electronics (5-times, 10-times, 25-times, 50-times or 100-times) |
| N | Factor for evaluation mode (counter) N = 1 for single-edge evaluation N = 4 for 4-edge evaluation |

6.3 Accuracy

Accuracy (extremes of direction deviations) is affected by

- Graduation errors of the graduated disk
- Eccentricity of the graduation relative to the axis bearing
- Radial eccentricity of the axis bearing
- Deviations in the positions of the graduated disk and the scanning head (mounting tolerances)
- Interpolation error in signal processing

The accuracy is largely determined by the eccentricity of the graduation relative to the axis bearing and the radial eccentricity of the axis bearing. The error resulting from these factors is calculated using the following formula:

$$\Delta\phi = \pm 412 \frac{e}{D}$$

| | |
|--------------|--|
| $\Delta\phi$ | Angular error [Arc seconds] |
| e | Eccentricity of the graduation relative to the rotational axis including the radial eccentricity of the axis bearing [μm] |
| D | Graduation diameter of the graduated disk [mm] |

6.4 Mechanical Data

| RIK 4 | |
|--|--|
| Weight of scan head (w/o cable) | 3 - 6 g |
| Number of counting pulses / rev. (with signal interpolation and 4-edge evaluation) | up to 9,600,000 |
| Available diameter of graduated disks (Ø of graduation) | <ul style="list-style-type: none"> • 19 mm • 29 mm • 39 mm • 45 mm • 64 mm • 92 mm • 142 mm • 192 mm |

Chart 3

6.5 Calculation of the Attainable Speed of Rotation

The maximum attainable speed of rotation of the encoder is determined by the maximum output frequency of the interpolator and/or the maximum counting frequency of the operator's evaluation electronics.

In order to avoid counting errors, the interpolator's output frequency is matched to the counting frequency of the operator's evaluation electronics.

This adaptation is possible in discrete frequency steps.

The maximum attainable speed of rotation (n_{\max}) is calculated according to the following formula:

$$n_{\max} = \frac{f \cdot 60}{i \cdot SF \cdot 4 \cdot Z} \quad [\text{rpm}]$$

| | |
|----|--|
| f | Clock frequency of the counter [Hz] |
| i | Interpolation factor (5-times, 10-times, 25-times, 50-times or 100-times) |
| SF | Safety factor = 1.5 |
| 4 | 4-edge evaluation |
| Z | Number of lines (Graduated disk) |

6.6 Electrical Data

| RIK 4 | |
|---|---|
| Scanning frequency | max. 500 kHz |
| Output Interfaces | |
| Voltage output | 1 V _{PP} (15-pin D-Sub) |
| Square wave output | RS-422 with interpolation up to 100-times (15-pin D-Sub) |
| Supply voltage | 5 V ±10% |
| Current Consumption | |
| Voltage output | ≤80 mA* |
| Square wave output | ≤210 mA* |
| Cable | |
| Cable diameter | 3.7 mm |
| Permissible bending radius | <ul style="list-style-type: none"> occasional flexing ~8 mm constant flexing ~40 mm |
| Length from scan head to the D-Sub connector | 3 m (standard: 0.3 m, 0.5 m, 1.0 m, 1.5 m, 2.0 m, 3.0 m) |
| Length from D-Sub connector to the controller | max. 100 m (The necessary supply voltage must be ensured!) |

* with 120 Ω load resistance

Chart 4

6.7 Switch-On Behaviour

During power-up procedure of the encoder system the level of power voltage and signal lines must be below 250 mV.



If the encoder system will be powered-up at a residual voltage between a range of 250 and 400 mV, internal sensor parameter will not set correctly. This will lead to incorrect encoder signals.

This behaviour has to be observed especially during reset routines of controllers.

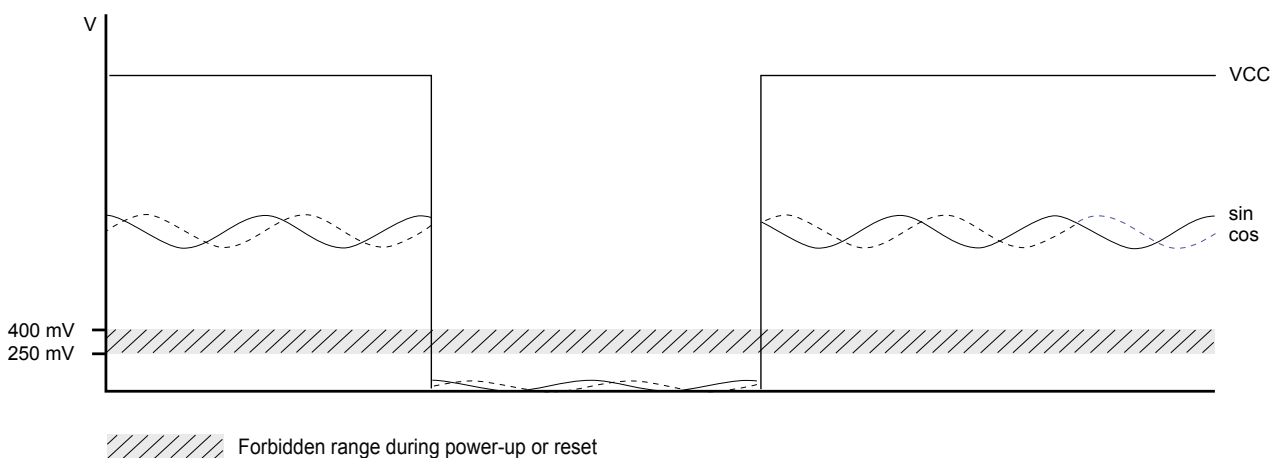

Image 5

6.8 Ambient Conditions

| | RIK 4 |
|--------------------------------|--|
| Operating temperature range | 0°C to +55°C (+32°F to +131°F) |
| Storage temperature range | -20°C to +70°C (-4°F to +158°F) |
| Vibration (50 Hz ... 2,000 Hz) | ≤200 ms ⁻² (20 g) |
| Shock (11 ms) | ≤400 ms ⁻² (40 g) |
| Humidity | ≤93% relative humidity (no condensation forming) |

Chart 5

6.9 Cable

Scanning Head Cable (connection cable from scanning head to D-Sub connector)

- Provide a strain relief for the cable near the scanning head.
- The encoder cables and connecting cables must be laid away from sources of interference (e.g. mains cables, fuses, motors, magnetic valves or power supplies). Normally a distance of ≥100 mm will be sufficient.
- Install the cable in a way that it cannot be damaged by the rotating hub. Please pay attention to the permissible bending radius (see also point 7.2)!

Extension Cable (connection cable from D-Sub connector to controller)

- Use preferably original extension cables made by NUMERIK JENA. This guarantees an optimum compatibility with the encoders and ensures a maximum protection against electromagnetic interferences.
- Please consult the technical support of NUMERIK JENA before using selfmanufactured extension cables.
- Do not install any other signal lines in the encoder cable!

6.10 Connector

15-pin D-Sub Connector

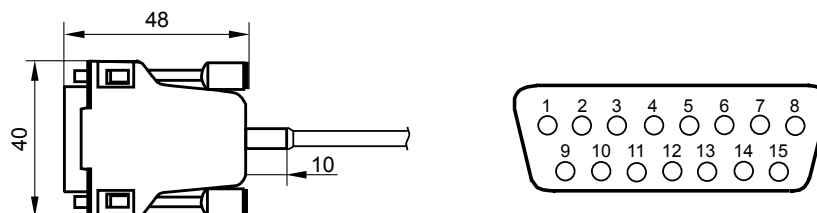

Image 6

6.11 PIN Assignment

15-pin D-Sub Connector

| PIN | 1 | 2 | 3 | 4 | 5 | 6 | 7 | 8 | 9 | 10 | 11 | 12 | 13 | 14 | 15 | Housing |
|-------------------|---|---|-----|-----------------|-----------------|-----------------|---|----|----|----|----|-----------------|-----------------|-----------------|----|---------|
| 1 V _{PP} | - | - | - | U ₀₋ | U ₂₋ | U ₁₋ | - | 5V | 0V | - | - | U ₀₊ | U ₂₊ | U ₁₊ | - | Shield |
| RS 422 | - | - | NAS | Z ₀₋ | Z ₂₋ | Z ₁₋ | - | 5V | 0V | - | AS | Z ₀₊ | Z ₂₊ | Z ₁₊ | - | Shield |
| Cable Ø 3.7 mm | - | - | vt | pk | rd | bn | - | bu | wh | - | ye | gy | bk | gn | - | - |

1 V_{PP}

U₁₊ Counting signal 0° (sin)
 U₁₋ Counting signal 180° (-sin)
 U₂₊ Counting signal 90° (cos)
 U₂₋ Counting signal 270° (-cos)
 U₀₊ Reference signal
 U₀₋ Negated reference signal

RS 422

Z₁₊ Counting signal 0°
 Z₁₋ Negated counting signal 0° (180°)
 Z₂₊ Counting signal 90°
 Z₂₋ Negated counting signal 90° (270°)
 Z₀₊ Reference signal
 Z₀₋ Negated reference signal

0V Ground (GND)

5V Operating voltage (U_B)

AS Error signal (monitoring signal)

NAS Negated error signal

NAS high: Input signal within the tolerance range

NAS low: Input signal outside the tolerance range (check measuring system!)

SCL Programming wire clock

SDA Programming wire data

6.12 Electromagnetic Compatibility (EMC)



Please observe the following to ensure maximum protection against electrical and magnetic fields:

- The encoder must be mounted to a galvanic conductive surface. The mounting surfaces, the threads of the mounting screws and the threads in the machine must be free from electrically non-conductive coatings.
- Maintain the NUMERIK JENA shielding concept for the measuring system!
- Shielding for encoders without connectors:
 - When connected directly with the evaluation electronics, ensure that the external shield of the cable is well grounded
 - If cable connectors (e.g. terminal strips, etc.) are used, connect the external shields of the cables with each other and with the shielding of the cable connector
- When using additional electronics, connect the housing electrically conducting to ensure good galvanic conductivity. For insulated installation the housing should be connected at the shortest distance by an additional potential equalization line (Cu line with cross section $\geq 6 \text{ mm}^2$) with the machine's protective ground.
- Please contact the NUMERIK JENA support or that of the appropriate manufacturer if you experience any problems when working with specific display or control units.

6.13 Shielding Concepts

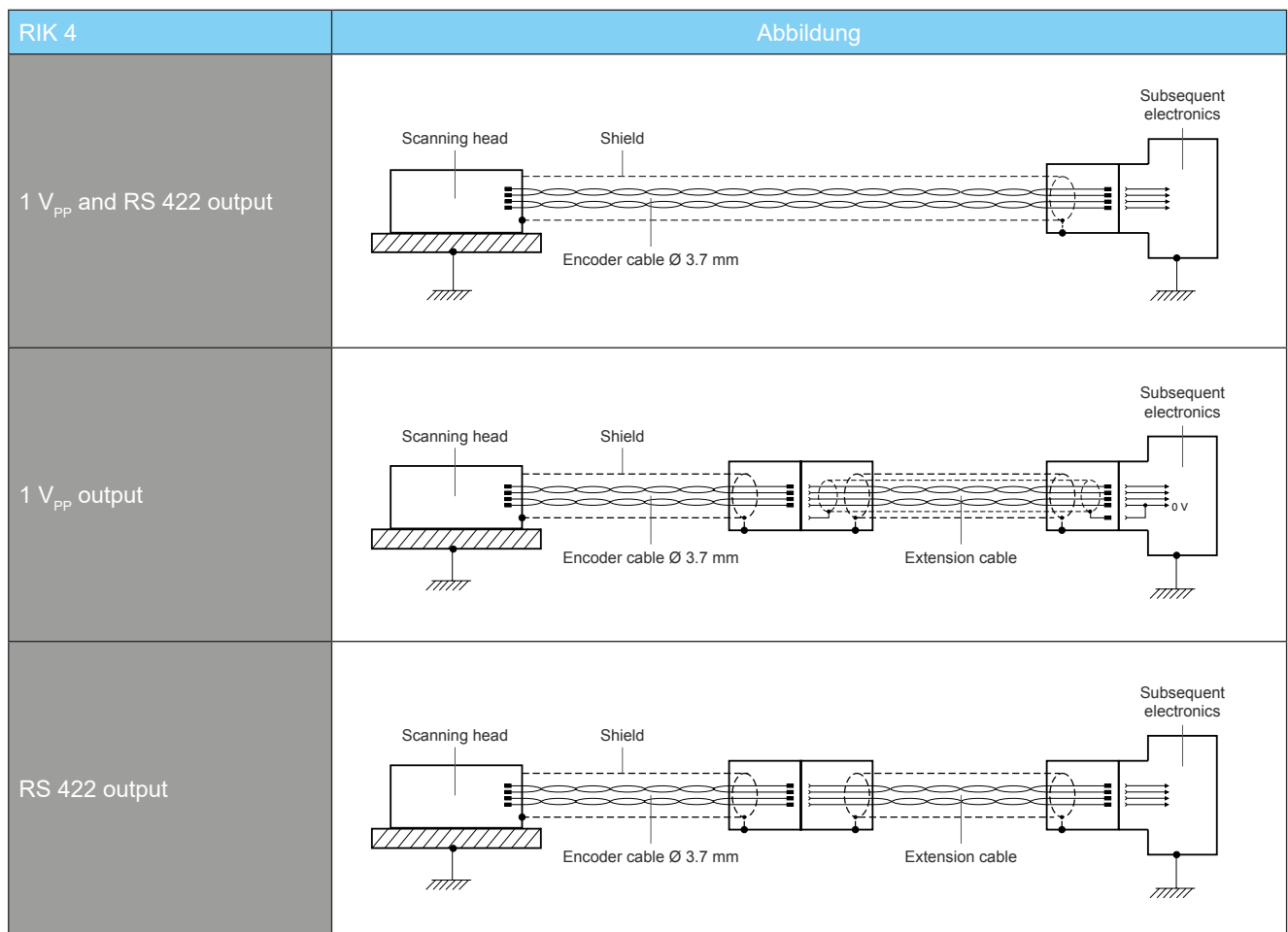

Chart 6

6.14 Voltage Output 1 V_{PP}

Optimal Connection Circuit

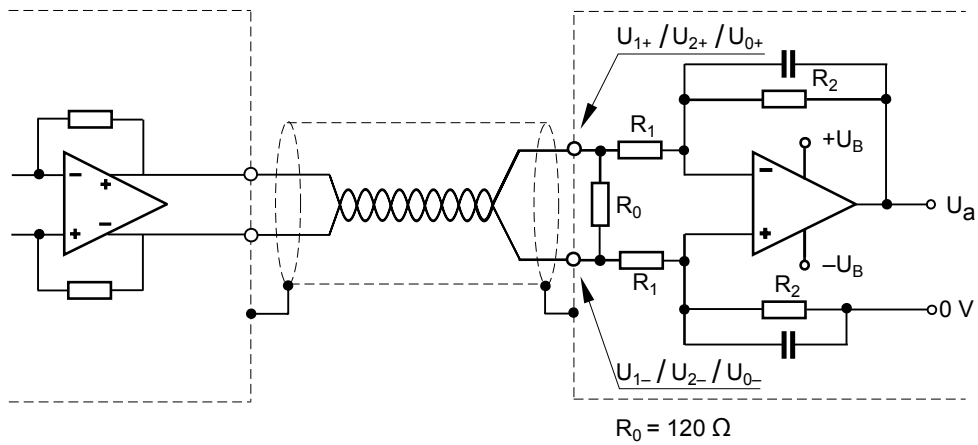

Image 7

Signal Curve

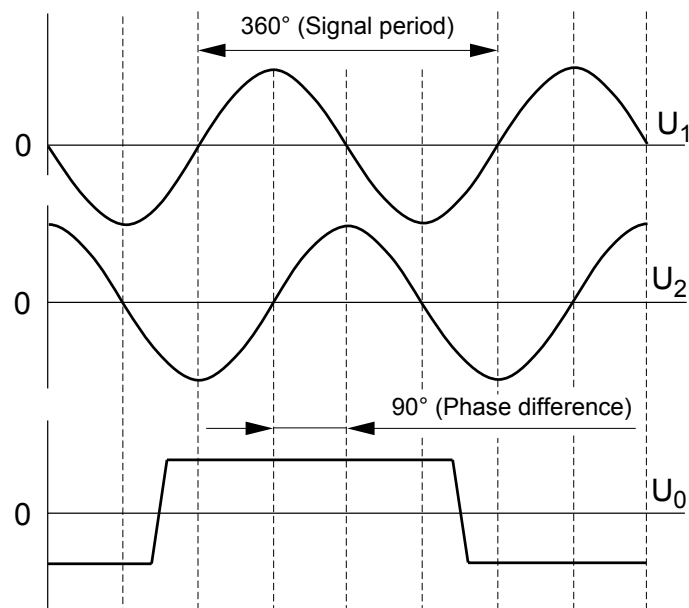

Image 8

Difference signals measured at R_0 :

$$U_1 = U_{1+} - U_{1-} = 0.6 \dots 1.2 V_{PP} \quad (\text{Rated voltage: } 1 V_{PP})$$

$$U_2 = U_{2+} - U_{2-} = 0.6 \dots 1.2 V_{PP} \quad (\text{Rated voltage: } 1 V_{PP})$$

$$U_0 = U_{0+} - U_{0-} = 0.5 \dots 1.2 V \quad (\text{Rated voltage: } 0.8 V)$$

6.15 Square-Wave Output RS-422

Optimal Connection Circuit

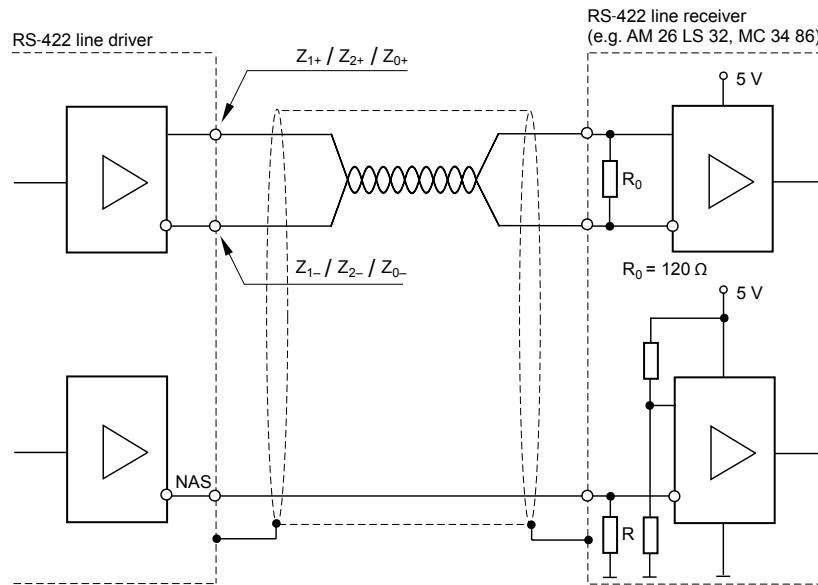

Image 9

Signal Curve

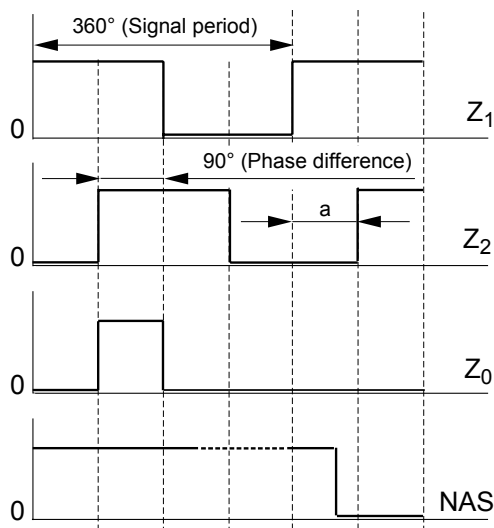

Image 10

NAS high:

Encoder functioning properly, input signals within tolerance range

NAS low:

Check the measuring system

a:

Minimum edge separation as a function of the interpolation factor and traversing speed

In order to avoid electromagnetic interference, the cable adaptation with a terminal resistor of $R_0 = 120 \Omega$ is necessary. When connecting more than one parallel signal input to an encoder output signal (e.g. linear motors with parallel connection to position controller, speed controller or acceleration controller) ensure that the resulting terminal resistance of these inputs is $R_{0res} \approx 120 \Omega$.

6.16 Online Compensation (Offset and Amplitude Control)

Contamination and mounting errors lead to interferences in the optical scanning of the graduated disk by the scanning head and so to periodic deformations of the sinusoidal counting track signals, which are exemplified as

- Offset deviations
- Amplitude deviations
- Amplitude differences between the sine and cosine channels and lead to interpolation errors.

Contaminated Graduated Disk

Scanning head signal with contaminated graduated disk before activation of the online compensation.

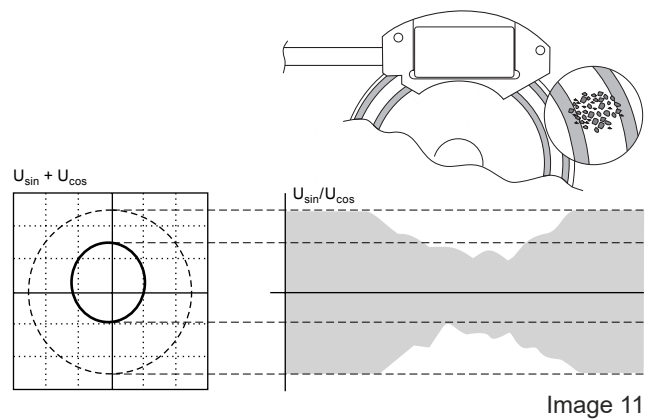

Incorrect Mounting

Scanning head signal with faulty mounting before activation of the online compensation.

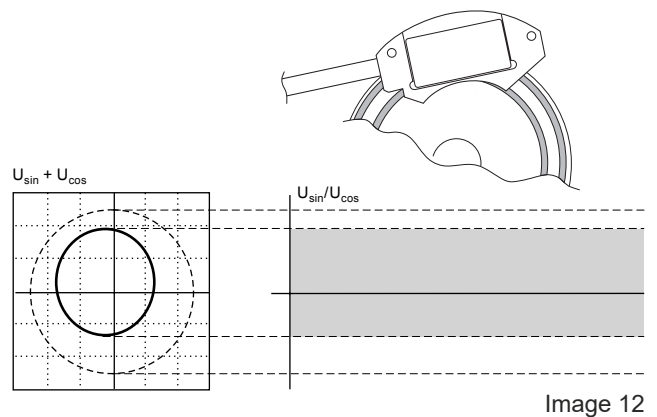

Active Online Compensation

Scanning head signal with contaminated graduated disk and/or faulty mounting after activation of the online compensation.

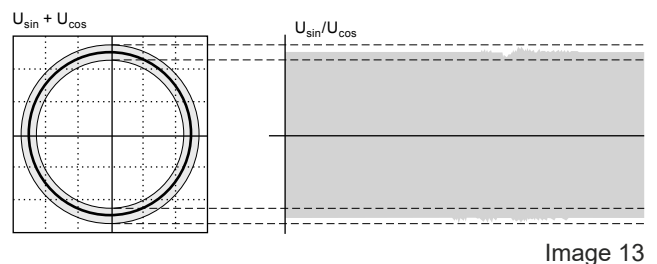

Through the online compensation the signals generated by the measuring module are automatically corrected within the sensor without following error over the entire velocity range.

This measure not only increases the accuracy, but also the reliability of the encoder.

7. General Mounting Instructions

7.1 Delivery Contents

Standard

- RIK 4 scanning head (according to the ordered specification)
- Graduated disk (according to the ordered specification)
- Information sheet

Optional

- ADJUSTMENT TOOL
- Extension cable

7.2 Encoder Mounting Position

- The mounting position of the encoder system is arbitrary.
- The operator of the encoder system is responsible for appropriate design measures to protect the scanning head and graduated disk from contamination.
- In any installation position the graduated disk and scanning window of the scanning head should be easily accessible for cleaning. Prevent contamination and foreign elements from having an influence on the operation!
- The counting direction of the encoder is positive (increasing measuring values) if the scanning head is positioned to the graduated disk like shown in the image below.

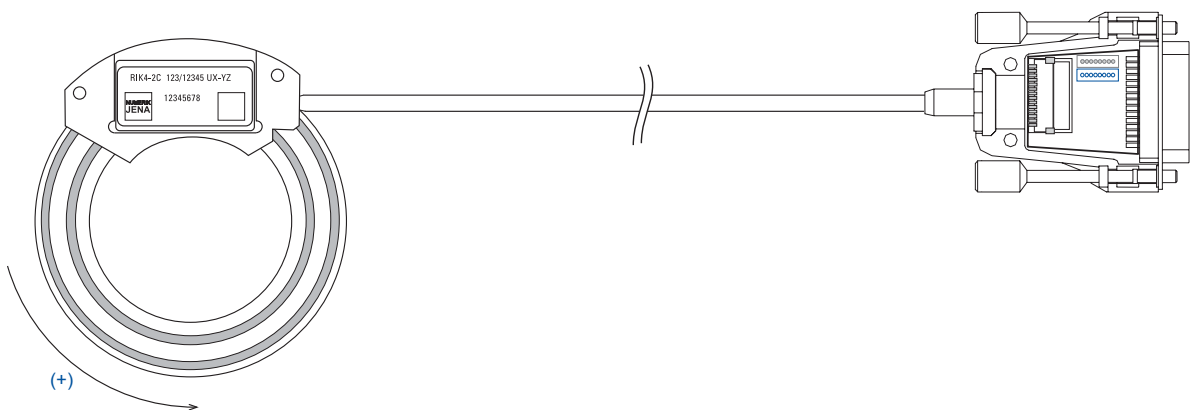

Image 14

7.3 Mounting of the Encoder System

The following shows the assembly of a RIK 4 encoder system. Scanning head and graduated disk must be positioned to each other like shown in the image.

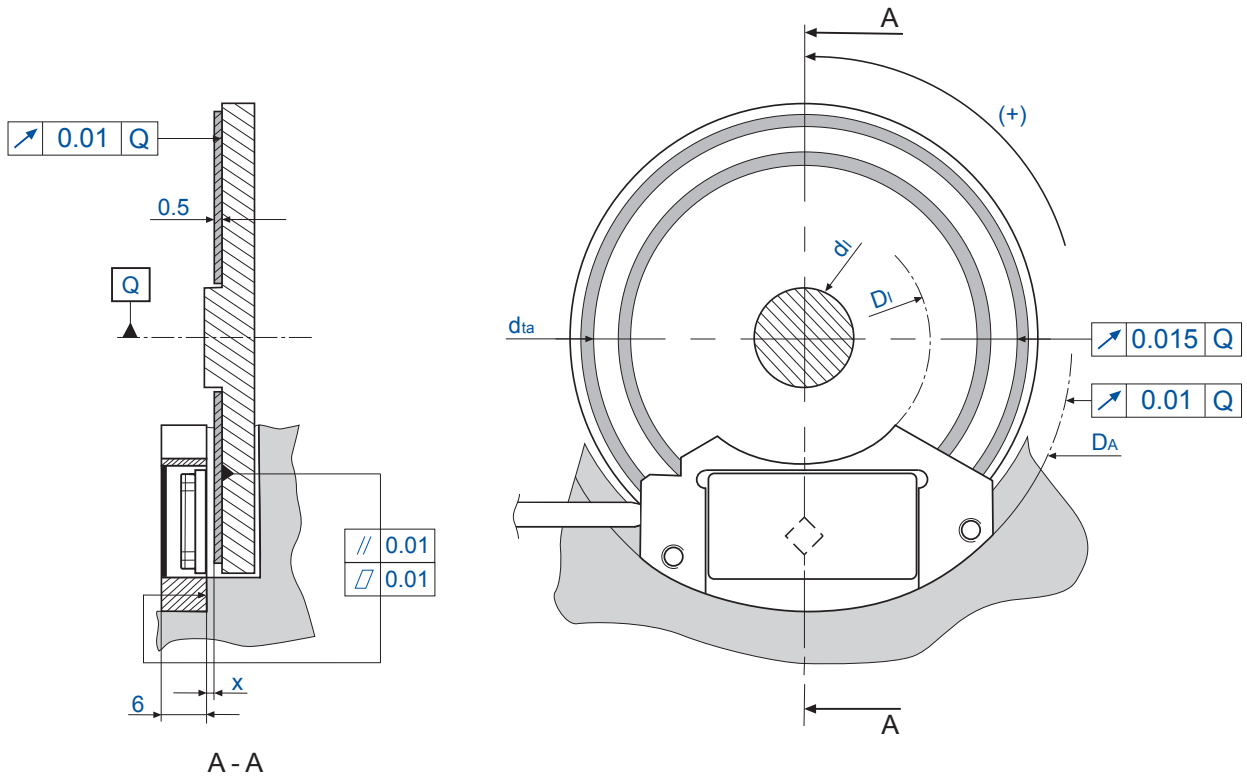

Image 15

- D_A Outside diameter of the stop surface (for scanning head)
- D_I Inside diameter of the stop surface (for scanning head)
- d_i Diameter of the axis
- d_{ta} Outer diameter of the incremental track
- x Working distance (air gap)

Notes on Assembling

The graduated disk must be adjusted regarding the rotational axis Q thus the center diameter of the incremental track d_{ta} observe the eccentricity R.

7.4 Dimensions and Mounting Tolerances

| Type | D_A [mm] | D_I [mm] | d_i [mm] | R [mm] | x |
|------------------|-------------------|--------------------|------------|--------|-----------|
| RS 19/6/3600 | 38 ^{H6} | - | - | 0.015 | 0.5 ±0.02 |
| RS 19/9/3600 | 38 ^{H6} | - | - | | 0.5 ±0.02 |
| RS 29/16/900 | 45 ^{H6} | 16 _{h6} | - | 0.015 | 0.6 ±0.1 |
| RS 29/16/1000 | 45 ^{H6} | 16 _{h6} | - | | 0.7 ±0.05 |
| RS 29/16/4500 | 45 ^{H6} | 16 _{h6} | - | | 0.6 ±0.05 |
| RS 29/20/900 | 45 ^{H6} | 16 _{h6} | - | | 0.6 ±0.1 |
| RS 39/9.97/3600 | 55 ^{H6} | 26 _{h6} | - | 0.015 | 0.4 ±0.05 |
| RS 39/25/1800 | 55 ^{H6} | 26 _{h6} | - | | 0.5 ±0.1 |
| RS 39/25/2048 | 55 ^{H6} | 26 _{h6} | - | | 0.7 ±0.1 |
| RS 39/25/3600 | 55 ^{H6} | 26 _{h6} | - | | 0.4 ±0.05 |
| RS 39/25/6000 | 55 ^{H6} | 26 _{h6} | - | | 0.6 ±0.05 |
| RS 39/30/3600 | 55 ^{H6} | 26 _{h6} | - | | 0.4 ±0.05 |
| RS 45/30/9000 | 64 ^{H6} | 34 _{h6} | - | 0.015 | 0.4 ±0.02 |
| RS 64/48.5/2048 | 82 ^{H6} | 50.8 _{h6} | - | 0.015 | 0.8 ±0.05 |
| RS 64/48.5/4096 | 82 ^{H6} | 50.8 _{h6} | - | | 0.6 ±0.05 |
| RS 64/48.5/9000 | 82 ^{H6} | 50.8 _{h6} | - | | 0.9 ±0.05 |
| RS 64/48.5/10000 | 82 ^{H6} | 50.8 _{h6} | - | | 0.7 ±0.05 |
| RS 92/70/3600 | 110 ^{H6} | 78 _{h6} | - | 0.015 | 0.5 ±0.1 |
| RS 92/70/9000 | 110 ^{H6} | 78 _{h6} | - | | 0.4 ±0.05 |
| RS 92/70/18000 | 110 ^{H6} | 78 _{h6} | - | | 0.4 ±0.05 |
| RS 92/76/3600 | 110 ^{H6} | 78 _{h6} | - | | 0.5 ±0.1 |
| RS 92/80/3600 | 110 ^{H6} | 78 _{h6} | - | | 0.5 ±0.1 |
| RS 142/120/5400 | 160 ^{H6} | 126 _{h6} | - | 0.015 | 0.8 ±0.05 |
| RS 142/120/18000 | 160 ^{H6} | 126 _{h6} | - | | 1.2 ±0.05 |
| RS 142/122/5400 | 160 ^{H6} | 126 _{h6} | - | | 0.8 ±0.05 |
| RS 142/128/18000 | 160 ^{H6} | 126 _{h6} | - | | 1.2 ±0.05 |
| RS 192/160/24000 | 210 ^{H6} | 180 _{h6} | - | 0.015 | 1.1 ±0.05 |

(regarding to image 18)

Chart 7

- D_A Outside diameter of the stop surface (for scanning head)
- D_I Inside diameter of the stop surface (for scanning head)
- d_i Diameter of the axis
- R Radial eccentricity - outer diameter of the incremental track
- x Working distance (air gap)

7.5 Mounting of the Graduated Disk

To prevent deformation of the graduated disk by external forces it is recommended to glue the disk to a hub (see image 16). Additionally the mounting and mechanical adjustment to a shaft will be simplified.

The use of a rotary table for mounting will be recommended. For optical vernier adjustment of the graduated disk an adjustment microscope with line marking in the intermediate image plane should be used.

Recommended Mounting Steps:

- 1 If necessary, clean all mounting surfaces before mounting by following the instructions in chapter 9 “Cleaning”.
- 2 Center and fix the hub to the rotary table.
- 3 Apply an evenly spreaded adhesive layer to the bottom of the graduated disk. The use of a two-component adhesive, e.g. “Epicol 230004” or an adhesive with similar properties is recommended. Use an appropriate tool, e.g. a dispenser.
- 4 Place the graduated disk on the hub carefully and center it primarily according to the outer diameter of the disk.
- 5 Focus the edge of the graduated disk by using the adjustment microscope. Rotate the graduated disk and determine the location of the minimum deviation **a** and the maximum deviation **b** of the concentricity (see image 17).
- 6 Focus the location of the minimum deviation **a** again and move the graduated disk carefully by half the amount of the difference between deviation **a** and deviation **b**. By doing so the centre of the incremental track and the pivot of the shaft will be aligned.
- 7 Weight down the graduated disk by using an appropriate loading (see image 18) and let the adhesive cure for approximately 1 hour. Please prevent any damage or scratching of the graduated disk by using an appropriate padding between disk and loading.
- 8 Focus the outer diameter of the incremental track of the graduated disk for vernier adjustment. Rotate the disk and determine the location of the minimum deviation **a** and the maximum deviation **b** again.
- 9 Repeat as well as described in step 6. Examine the concentricity and repeat step 6 as often as necessary to reach the required concentricity deviation. Let the adhesive cure (e.g. “Epicol 230004”, curing time = 24 hours at room temperature).
- 10 Finally fix and center the hub to the shaft.

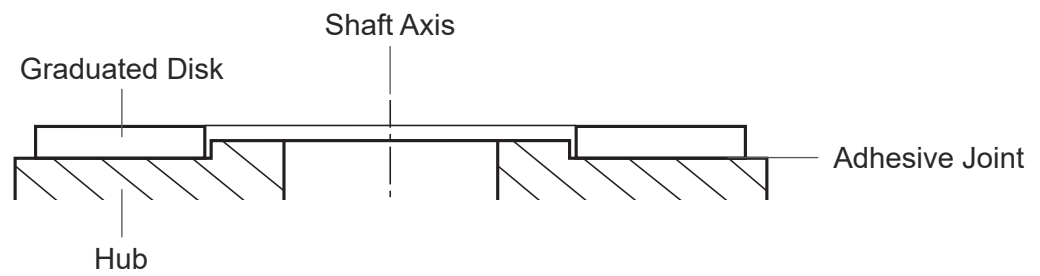

Image 16

Centering of the Graduated Disk with an Adjustment Microscope

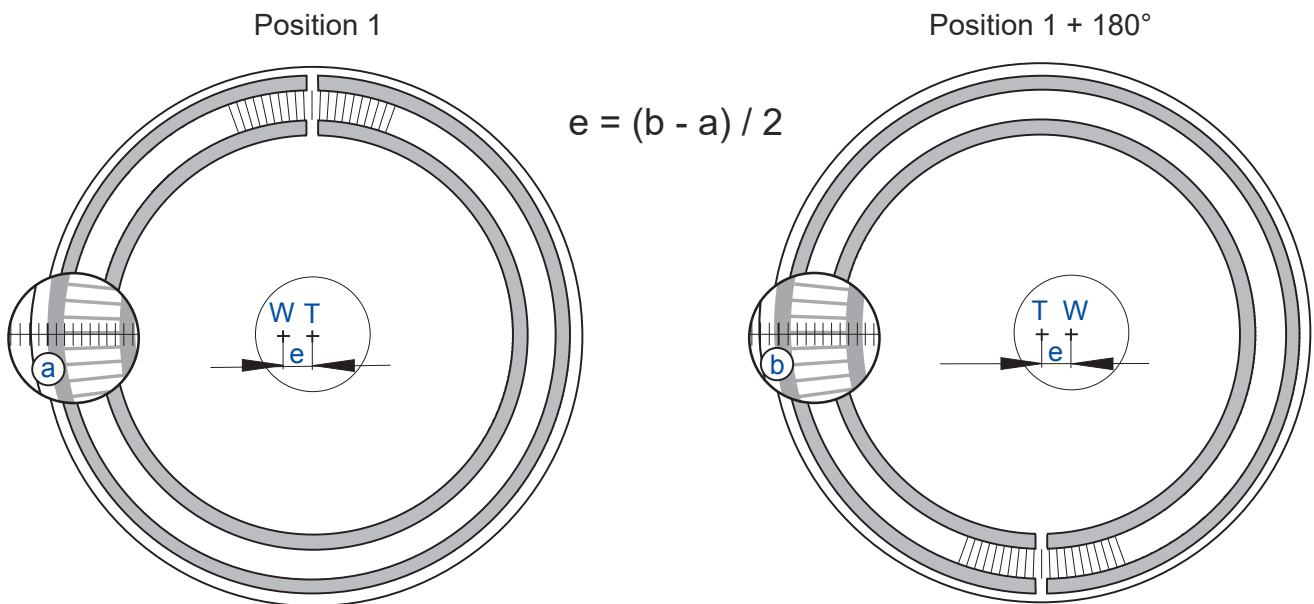

Image 17

- W Center of the axis
- T Center of the incremental track
- e Centering error
- a Minimum deviation
- b Maximum deviation

Mounting Example with Loading After Glueing the Graduated Disk

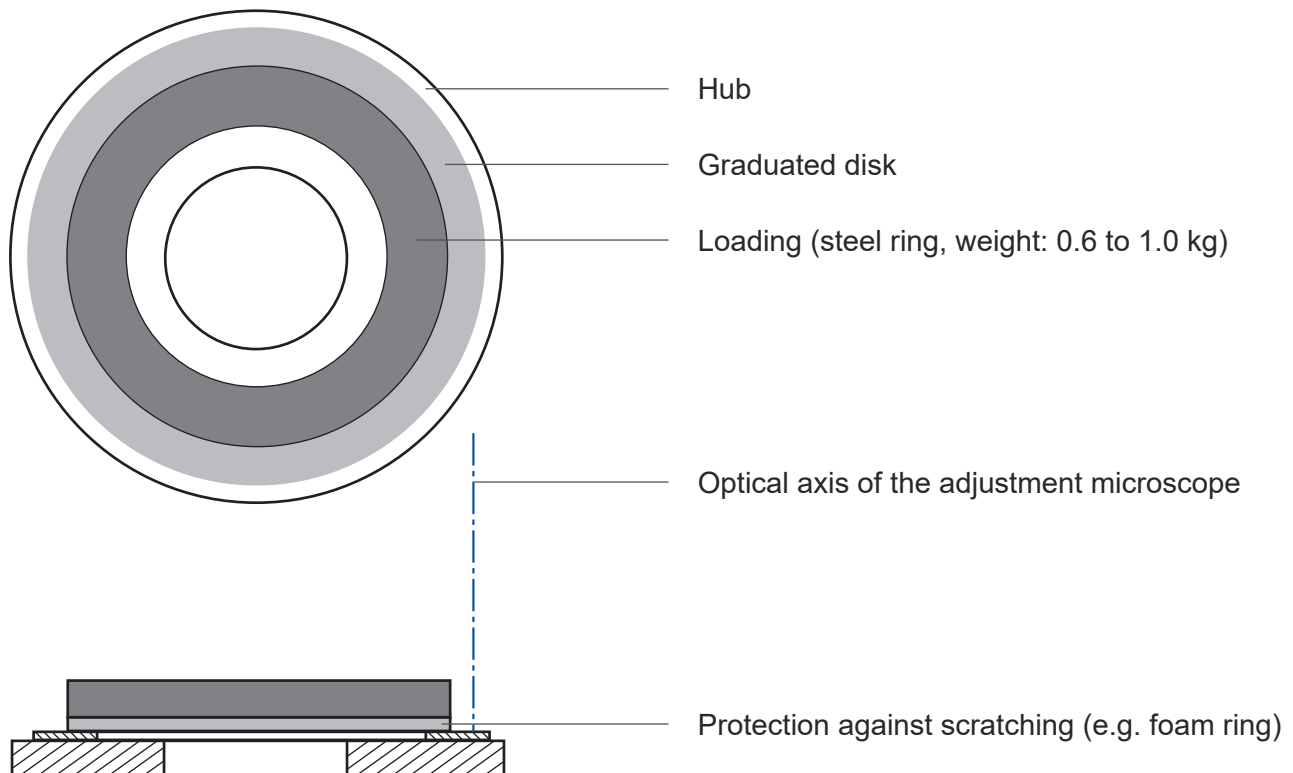

Image 18

Mounting Instructions

- Remove any residue of adhesive which appeared during the mounting procedure from hub and graduated disk immediately.
- Clean the surfaces by following the instructions in chapter 9 “Cleaning”.
- Please prevent any damage or scratching of the graduated disk while removing the loading. The surface of the graduated disk is very scratch-sensitive.
- Please pay attention to the data sheets and notes of the adhesive manufacturer!

Notes

NUMERIK JENA offers the mechanical mounting as well as the adjustment of the graduated disk to a customized hub as a service. The manufacturing of the customized hub can be done by NUMERIK JENA also.

The hub must be designed principally as prescribed in the following image.

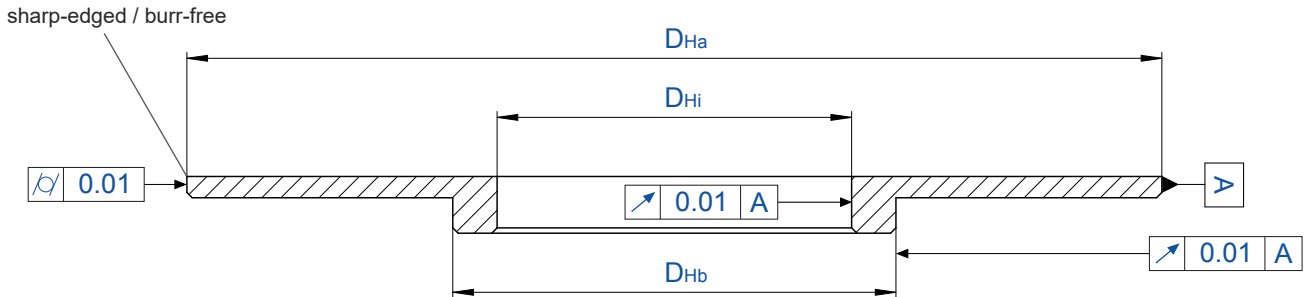

Image 19

- D_{Ha} Outside diameter of the hub
- D_{Hi} Inside diameter of the hub
- D_{Hb} Adjustment diameter of the hub

The inside as well as the outside diameter must be designed as prescribed in the following:

- $D_{Ha} \geq$ Outside diameter of the graduated disk + 1.0 mm
- $D_{Hi} \leq$ Inside diameter of the graduated disk - 1.0 mm

The inside diameter D_{Hi} as well as the adjustment diameter D_{Hb} can be used for the mechanical adjustment on a rotary table. For mounting at NUMERIK JENA the diameter must not exceed or exceed the following values:

- D_{Hi} 26 ... 135 mm
- D_{Hb} 30 ... 140 mm

7.6 Mounting of the Scanning Head

- If necessary, clean all mounting surfaces of the scanning head and machine element before mounting by following the instructions in chapter 9 “Cleaning”.
- Remove the protection foil from the scanning window of the scanning head.
- The mechanical mounting of the scanning head can be done in two ways:

Mounting of a Scanning Head with Through-Holes Ø 2.2 mm

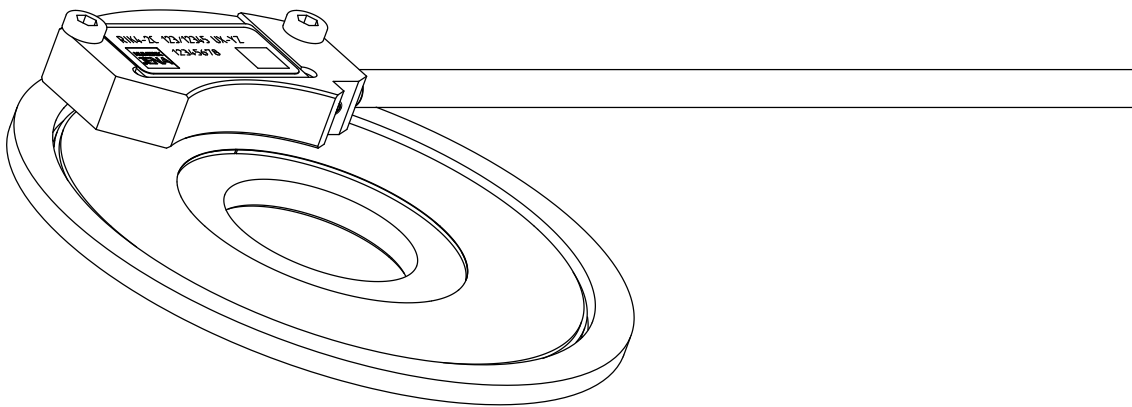

Image 20

Mounting of a Scanning Head with Internal Screw Threads M2.5

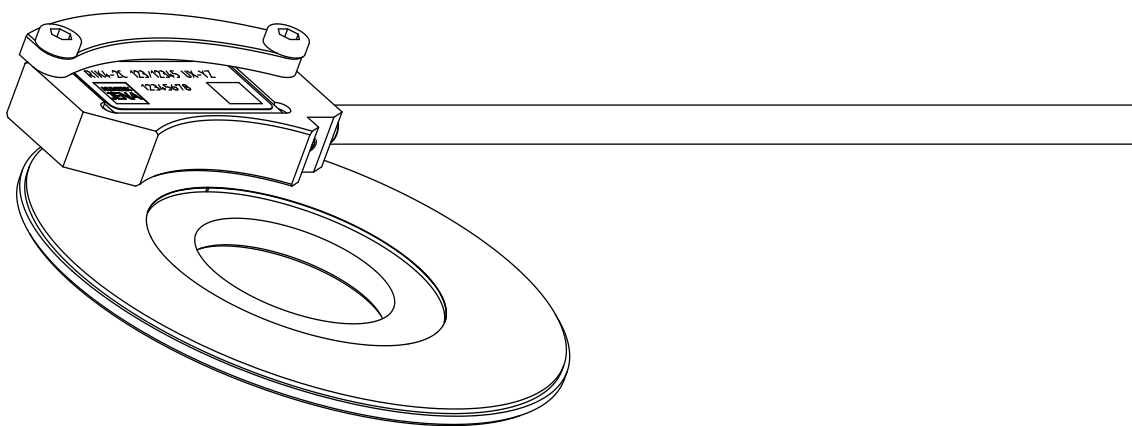

Image 21

-
- Please pay attention to the indicated mechanical mounting tolerances (see point 7.3 and 7.4).
 - Position the encoder cable including a strain relief near the scanning head (see also point 6.9).
 - Connect the encoder cable to the evaluation electronics and pay attention to the pin assignment.
The evaluation electronics must be switched off!
 - After connecting the encoder cable switch the evaluation electronics on and test the functionality.
 - If there are errors in the function or during measurement, please read chapter 10 “Troubleshooting” first. If these information are not helpful for your problem, please contact the technical support of NUMERIK JENA or an authorized subsidiary in your country.

8. Signal Adjustment with ADJUSTMENT TOOL

Before delivery the encoders from NUMERIK JENA will be tested and electronically adjusted under ideal mounting conditions. Furthermore, the sensor modules offer the possibility of an electronic signal adjustment after the mounting into the application. This allows the user optimize the encoder signals regarding to the mechanical mounting conditions (tolerances).

The ADJUSTMENT TOOL and the related EPIFLEX software was designed to simplify and make the signal adjustment more effective.

8.1 Functions of the ADJUSTMENT TOOL

- Representation of the sinusoidal counting signals with amplitude, offset and phase position
- Representation of the position and width of the index signal
- Evaluation of the mechanical mounting conditions
- Automatic signal adjustment and programming of the sensor module
- Electronic readjustment of the amplitude and offset of the sensor signals
- Adjustment of the position and width of the index signal

8.2 Dynamic Offset and Amplitude Control (Online Compensation)

The encoders of NUMERIK JENA are equipped with a dynamic amplitude and offset control (online compensation). The analog diode signals will be corrected to their nominal values in real time. This reduces measuring errors caused by contamination as well as from inaccuracies. The phase position between the sine and cosine signals and the position of the index signal are not influenced by the online compensation.

With help of the EPIFLEX Software the preadjusted nominal values of the online compensation can be influenced.

8.3 Scope of Delivery

- ADJUSTMENT TOOL black box
- Diagnostic cable to connect the measuring system
- USB cable to connect a PC
- USB - D-SUB - adapter cable (15-pin)
- Exchangeable 8-pin plug connectors



Image 22

8.4 EPIFLEX Software

The EPIFLEX software was especially designed for the ADJUSTMENT TOOL. It offers the user versatile possibilities to bring the encoder into service. It also allows the user to display the sensor signals and evaluate them without using an oscilloscope or other expensive hardware. Furthermore it is possible to program respectively optimize the encoder to the existing mounting conditions automatically.

The EPIFLEX software is available for free via download on the NUMERIK JENA website under www.numerikjena.com. Furthermore, one can order the software with an optional USB flash drive.

The EPIFLEX software is suitable for the following operating systems:

- Windows 7, 8, 10 (32 or 64 bit)

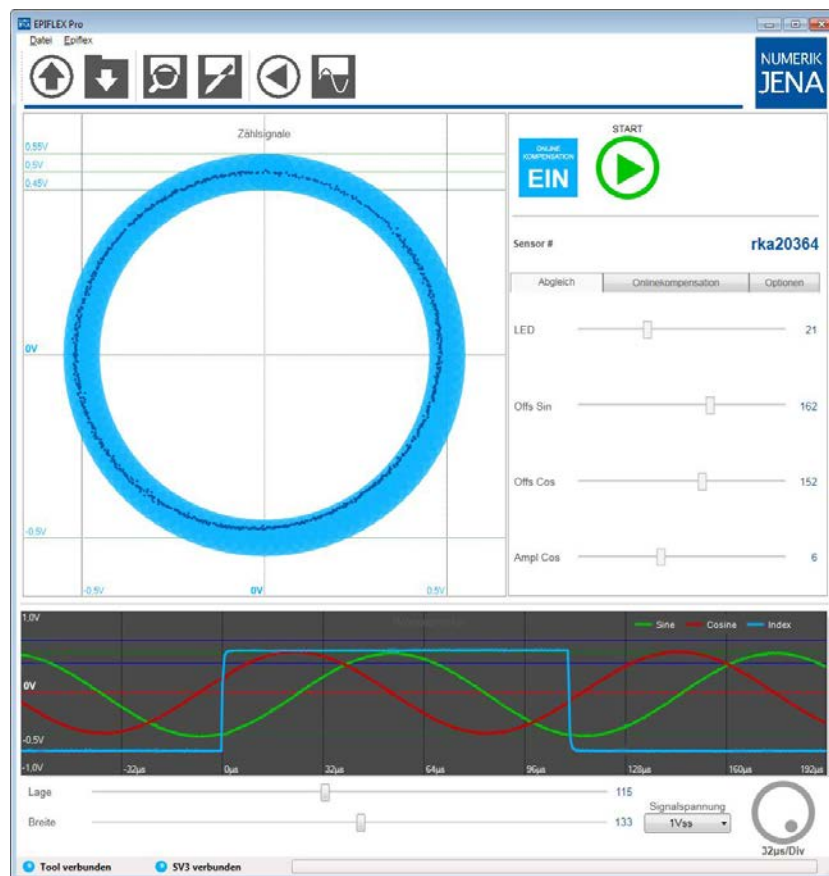

Image 23

Further information about the ADJUSTMENT TOOL and the EPIFLEX software can be found on the NUMERIK JENA website.

9. Cleaning

- The measuring systems from NUMERIK JENA are delivered in a pre-cleaned condition. Re-cleaning of the surfaces is only recommended if they have been contaminated during installation of the components.
- During operation of the measuring system in a plant, occasional cleaning of the sensor surface of the scanning head (scanning window for counting and reference track) or the graduated disk may be necessary, depending on the installation position and the ambient conditions.
- When using the monitoring signal output by the sensor head, the need for cleaning may be indicated.
- When cleaning the components, make sure that deposited particles do not scratch the scanning window of the scanning head or the surface of the graduated disk! The surfaces of the scanning window and the graduated disk are sensitive to scratches and should only be cleaned with extreme care.
- Clean with absorbent cotton or a soft, lint-free cloth using a solvent. Cleaning without a solvent increases the risk of damaging the surfaces. Only isopropanol or acetone is recommended as a solvent. The use of other solvents may damage the surfaces.
- When cleaning the disks surface, adhere to the wiping direction specified in image 24. Wiping across the applied increments increases the risk of damage and can lead to failure of the measuring system.
- Avoid contact between solvents and the adhesive layer! This can cause the adhesive layer to dissolve and thus reduce the adhesive strength or cause the graduated disk to detach completely.
- ATTENTION: Isopropanol and acetone are flammable liquids!

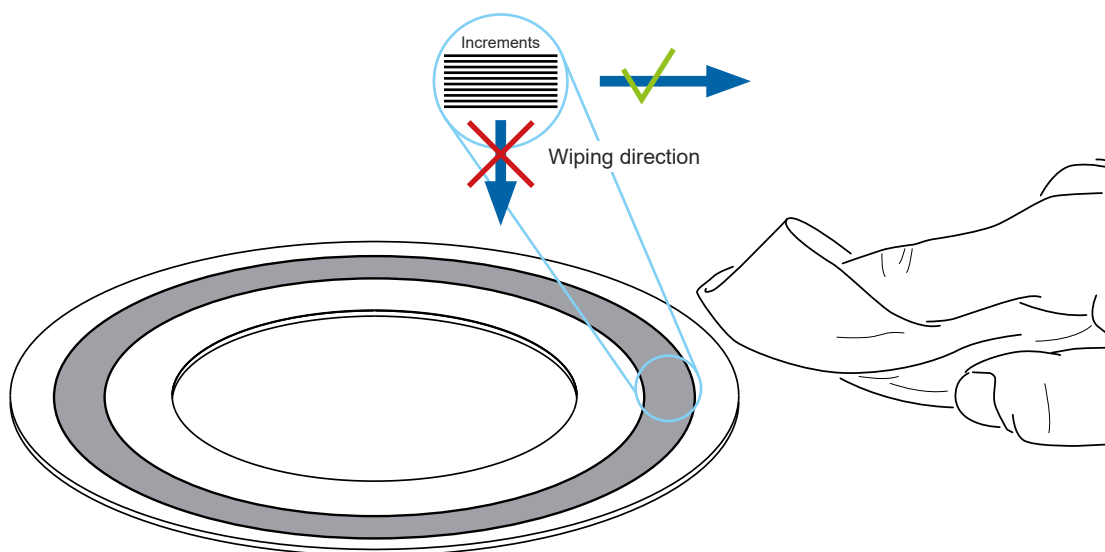

Image 24

10. Troubleshooting

The functions of all scanning heads and accuracy of all scale tapes are tested before the encoders are shipped. However, if troubles or problems should occur, please read the following points in the chart and proceed according these information.

If this is not helpful, please contact the technical support of NUMERIK JENA GmbH or one of our authorized subsidiaries. You will find respective contact data on the NUMERIK JENA webside www.numerikjena.com.

| Error | Possible causes | Solution |
|--|---|--|
| No measuring signal | No power at the scanning head | <ul style="list-style-type: none"> • Check the status of the evaluation electronics • Check the connection assignment between the encoder and the evaluation electronics |
| Error message from the evaluation electronics | Following error due to temporary failure of the measuring signal | <ul style="list-style-type: none"> • Check the assignment of the graduated disk to the scanning head • p.r.n. readjust mechanically • Readjust electronically with ADJUSTMENT TOOL* |
| Rough, loud motor running | Irregular edge separations of the counting signals due to interpolation errors | |
| Counting error (compared to a standard) | Mounting error | |
| No reference signal | Mounting error (results in faulty gating of the reference signal and counting signal) | |
| Reference mark can only be detected from one direction | | |
| Reference mark appears twice | | |
| Not all reference marks are detected | | |
| Failure signal reports (for RS-422) | Mounting error (results in level of the analog signal from the sensor being too low) | Clean the graduated disk (see also chapter 9 „Cleaning“) |
| | Contamination on the graduated disk (results in level of the analog signal from the sensor being too low) | |
| | Encoder function operating error | Contact the technical support of NUMERIK JENA |

Chart 8

* see also chapter 8

11. Ordering Key

11.1 Scanning Head

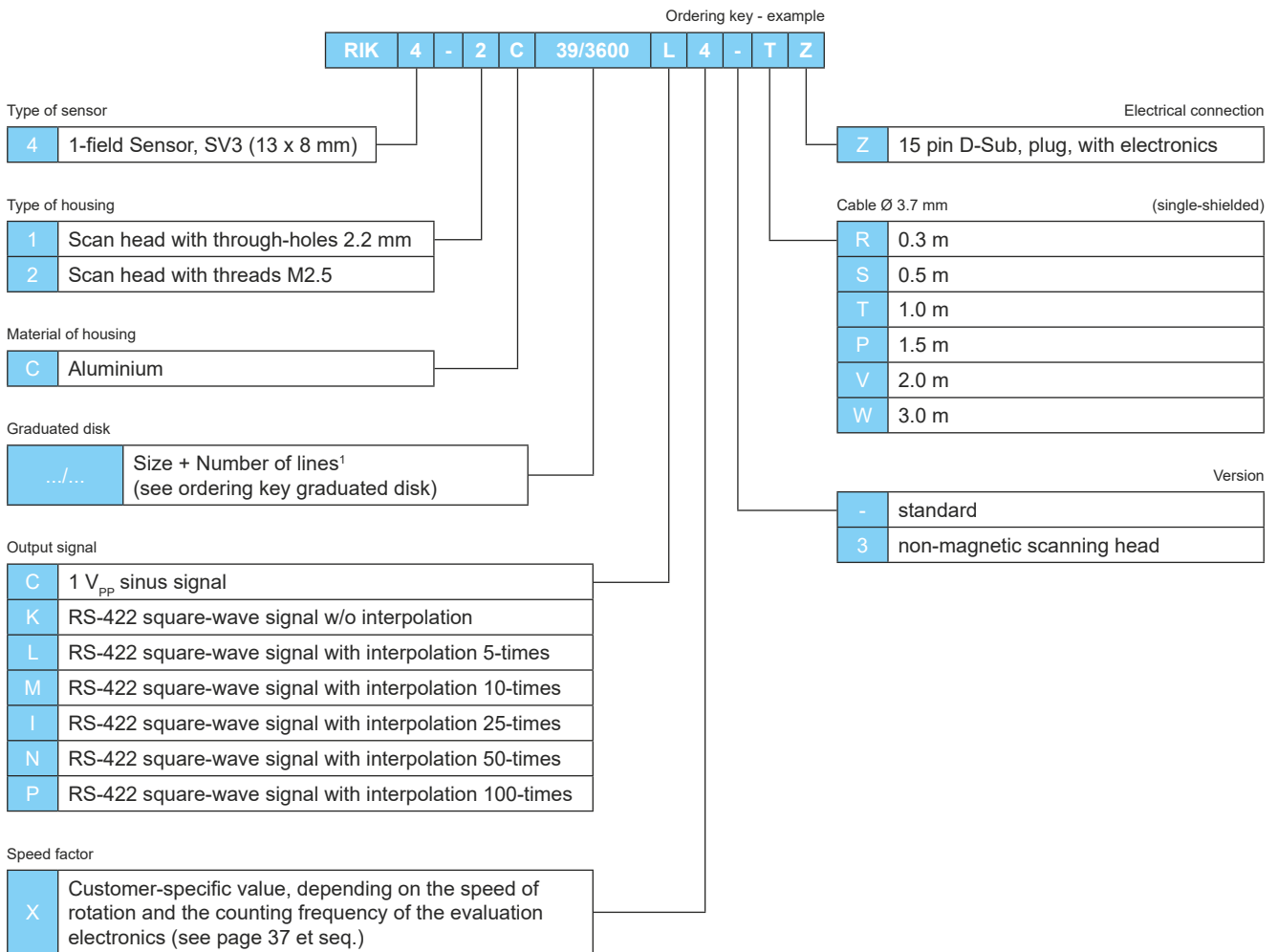

¹ The chosen combination of size + number of lines in the ordering key scanning head must be identical to the chosen graduated disk.

NOTE

Deviations from the standard configurations listed here are possible in principle. We would be happy to work with you to develop your individual solution. Simply get in touch with your local contact person. You will find a corresponding contact list on our website under "Contact".

11.2 Speed Chart for RIK Series

11.2.1 RIK 4 with Op-Amp

The maximum attainable speed of rotation of the encoder is determined by the maximum output frequency of the interpolator and/or the maximum counting frequency of the operator's evaluation electronics (e.g. controller or display).

Please take the suitable values for your application from the following charts and enter it into the corresponding place (for "X") in the ordering key. Pay attention to your chosen interpolation factor and the number of lines of the graduated disk first. If you have found the respective information, please check if your evaluation electronics is able to achieve the needed counting frequency and the maximum speed of rotation. The maximum speed of rotation should not be exceeded.

The maximum scanning frequency of the encoder amounts to 200 kHz standardly, hence the maximum attainable speed of rotation will be derived from that. The op-amp decouples parasitic frequencies and improves the interference immunity of the encoder under unfavorable conditions. The encoders from NUMERIK JENA are available without op-amp also. Thus it is possible to increase the scanning frequency which consequently enables higher speed of rotation.

C Without interpolation factor

| Value for X | Number of lines (Z) | | | | | | | | | | | | | | Min. counting frequency of the evaluation electronics (in MHz) | |
|-------------|---------------------|--------|-------|-------|-------|-------|-------|-------|-------|-------|--------|--------|--------|--------|--|------------------------|
| | 900 | 1,000 | 1,800 | 2,048 | 3,600 | 4,096 | 4,500 | 5,400 | 6,000 | 9,000 | 10,000 | 18,000 | 24,000 | 32,000 | w/o 4-edge evaluation | with 4-edge evaluation |
| 0 | 13,333 | 12,000 | 6,667 | 5,859 | 3,333 | 2,930 | 2,667 | 2,222 | 2,000 | 1,333 | 1,200 | 667 | 500 | 375 | 0.25 | 1 |

L Interpolation factor = 5

| Value for X | Number of lines (Z) | | | | | | | | | | | | | | Min. counting frequency of the evaluation electronics (in MHz) | |
|-------------|---------------------|--------|-------|-------|-------|-------|-------|-------|-------|-------|--------|--------|--------|--------|--|------------------------|
| | 900 | 1,000 | 1,800 | 2,048 | 3,600 | 4,096 | 4,500 | 5,400 | 6,000 | 9,000 | 10,000 | 18,000 | 24,000 | 32,000 | w/o 4-edge evaluation | with 4-edge evaluation |
| 1 | 2,222 | 2,000 | 1,111 | 977 | 556 | 488 | 444 | 370 | 333 | 222 | 200 | 111 | 83 | 63 | 0.25 | 1 |
| 2 | 4,444 | 4,000 | 2,222 | 1,953 | 1,111 | 977 | 889 | 741 | 667 | 444 | 400 | 222 | 167 | 125 | 0.50 | 2 |
| Y | 6,667 | 6,000 | 3,333 | 2,930 | 1,667 | 1,465 | 1,333 | 1,111 | 1,000 | 667 | 600 | 333 | 250 | 188 | 0.75 | 3 |
| 3 | 8,889 | 8,000 | 4,444 | 3,906 | 2,222 | 1,953 | 1,778 | 1,481 | 1,333 | 889 | 800 | 444 | 333 | 250 | 1.00 | 4 |
| Z | 13,333 | 12,000 | 6,667 | 5,859 | 3,333 | 2,930 | 2,667 | 2,222 | 2,000 | 1,333 | 1,200 | 667 | 500 | 375 | 1.50 | 6 |

M Interpolation factor = 10

| Value for X | Number of lines (Z) | | | | | | | | | | | | | | Min. counting frequency of the evaluation electronics (in MHz) | |
|-------------|---------------------|--------|-------|-------|-------|-------|-------|-------|-------|-------|--------|--------|--------|--------|--|------------------------|
| | 900 | 1,000 | 1,800 | 2,048 | 3,600 | 4,096 | 4,500 | 5,400 | 6,000 | 9,000 | 10,000 | 18,000 | 24,000 | 32,000 | w/o 4-edge evaluation | with 4-edge evaluation |
| 1 | 1,111 | 1,000 | 556 | 448 | 278 | 244 | 222 | 185 | 167 | 111 | 100 | 56 | 42 | 31 | 0.25 | 1 |
| 2 | 2,222 | 2,000 | 1,111 | 977 | 556 | 488 | 444 | 370 | 333 | 222 | 200 | 111 | 83 | 63 | 0.50 | 2 |
| Y | 3,333 | 3,000 | 1,667 | 1,465 | 833 | 732 | 667 | 556 | 500 | 333 | 300 | 167 | 125 | 94 | 0.75 | 3 |
| 3 | 4,444 | 4,000 | 2,222 | 1,953 | 1,111 | 977 | 889 | 741 | 667 | 444 | 400 | 222 | 167 | 125 | 1.00 | 4 |
| Z | 6,667 | 6,000 | 3,333 | 2,930 | 1,667 | 1,465 | 1,333 | 1,111 | 1,000 | 667 | 600 | 333 | 250 | 188 | 1.50 | 6 |
| 4 | 8,889 | 8,000 | 4,444 | 3,906 | 2,222 | 1,953 | 1,778 | 1,481 | 1,333 | 889 | 800 | 444 | 333 | 250 | 2.00 | 8 |
| 5 | 13,333 | 12,000 | 6,667 | 5,859 | 3,333 | 2,930 | 2,667 | 2,222 | 2,000 | 1,333 | 1,200 | 667 | 500 | 375 | 3.00 | 12 |

I Interpolation factor = 25

| Value for X | Number of lines (Z) | | | | | | | | | | | | | | Min. counting frequency of the evaluation electronics (in MHz) | |
|-------------|---------------------|-------|-------|-------|-------|-------|-------|-------|-------|-------|--------|--------|--------|--------|--|------------------------|
| | 900 | 1,000 | 1,800 | 2,048 | 3,600 | 4,096 | 4,500 | 5,400 | 6,000 | 9,000 | 10,000 | 18,000 | 24,000 | 32,000 | w/o 4-edge evaluation | with 4-edge evaluation |
| | [rpm] | | | | | | | | | | | | | | | |
| 1 | 444 | 400 | 222 | 195 | 111 | 98 | 89 | 74 | 67 | 44 | 40 | 22 | 17 | 13 | 0.25 | 1 |
| 2 | 889 | 800 | 444 | 391 | 222 | 195 | 178 | 148 | 133 | 89 | 80 | 44 | 33 | 25 | 0.50 | 2 |
| Y | 1,333 | 1,200 | 667 | 586 | 333 | 293 | 267 | 222 | 200 | 133 | 120 | 67 | 50 | 38 | 0.75 | 3 |
| 3 | 1,778 | 1,600 | 889 | 781 | 444 | 391 | 356 | 296 | 267 | 178 | 160 | 89 | 67 | 50 | 1.00 | 4 |
| Z | 2,667 | 2,400 | 1,333 | 1,172 | 667 | 586 | 533 | 444 | 400 | 267 | 240 | 133 | 100 | 75 | 1.50 | 6 |
| 4 | 3,556 | 3,200 | 1,778 | 1,563 | 889 | 781 | 711 | 593 | 533 | 356 | 320 | 178 | 133 | 100 | 2.00 | 8 |
| 5 | 5,333 | 4,800 | 2,667 | 2,344 | 1,333 | 1,172 | 1,067 | 889 | 800 | 533 | 480 | 267 | 200 | 150 | 3.00 | 12 |
| 6 | 7,111 | 6,400 | 3,556 | 3,125 | 1,778 | 1,563 | 1,422 | 1,185 | 1,067 | 711 | 640 | 356 | 267 | 200 | 4.00 | 16 |
| 7 | 8,889 | 8,000 | 4,444 | 3,906 | 2,222 | 1,953 | 1,778 | 1,481 | 1,333 | 889 | 800 | 444 | 333 | 250 | 5.00 | 20 |
| 8 | 10,667 | 9,600 | 5,333 | 4,688 | 2,677 | 2,344 | 2,133 | 1,778 | 1,600 | 1,067 | 960 | 533 | 400 | 300 | 6.00 | 24 |

N Interpolation factor = 50

| Value for X | Number of lines (Z) | | | | | | | | | | | | | | Min. counting frequency of the evaluation electronics (in MHz) | |
|-------------|---------------------|-------|-------|-------|-------|-------|-------|-------|-------|-------|--------|--------|--------|--------|--|------------------------|
| | 900 | 1,000 | 1,800 | 2,048 | 3,600 | 4,096 | 4,500 | 5,400 | 6,000 | 9,000 | 10,000 | 18,000 | 24,000 | 32,000 | w/o 4-edge evaluation | with 4-edge evaluation |
| | [rpm] | | | | | | | | | | | | | | | |
| 1 | 222 | 200 | 111 | 98 | 56 | 49 | 44 | 37 | 33 | 22 | 20 | 11 | 8 | 6 | 0.25 | 1 |
| 2 | 444 | 400 | 222 | 195 | 111 | 98 | 89 | 74 | 67 | 44 | 40 | 22 | 17 | 13 | 0.50 | 2 |
| Y | 667 | 600 | 333 | 293 | 167 | 146 | 133 | 111 | 100 | 67 | 60 | 33 | 25 | 19 | 0.75 | 3 |
| 3 | 889 | 800 | 444 | 391 | 222 | 195 | 178 | 148 | 133 | 89 | 80 | 44 | 33 | 25 | 1.00 | 4 |
| Z | 1,333 | 1,200 | 667 | 586 | 333 | 293 | 267 | 222 | 200 | 133 | 120 | 67 | 50 | 38 | 1.50 | 6 |
| 4 | 1,778 | 1,600 | 889 | 781 | 444 | 391 | 356 | 296 | 267 | 178 | 160 | 89 | 67 | 50 | 2.00 | 8 |
| 5 | 2,667 | 2,400 | 1,333 | 1,172 | 667 | 586 | 533 | 444 | 400 | 267 | 240 | 133 | 100 | 75 | 3.00 | 12 |
| 6 | 3,556 | 3,200 | 1,778 | 1,563 | 889 | 781 | 711 | 593 | 533 | 356 | 320 | 178 | 133 | 100 | 4.00 | 16 |
| 7 | 4,444 | 4,000 | 2,222 | 1,953 | 1,111 | 977 | 889 | 741 | 667 | 444 | 400 | 222 | 167 | 125 | 5.00 | 20 |
| 8 | 5,333 | 4,800 | 2,677 | 2,344 | 1,333 | 1,172 | 1,067 | 889 | 800 | 533 | 480 | 267 | 200 | 150 | 6.00 | 24 |

P Interpolation factor = 100

| Value for X | Number of lines (Z) | | | | | | | | | | | | | | Min. counting frequency of the evaluation electronics (in MHz) | |
|-------------|---------------------|-------|-------|-------|-------|-------|-------|-------|-------|-------|--------|--------|--------|--------|--|------------------------|
| | 900 | 1,000 | 1,800 | 2,048 | 3,600 | 4,096 | 4,500 | 5,400 | 6,000 | 9,000 | 10,000 | 18,000 | 24,000 | 32,000 | w/o 4-edge evaluation | with 4-edge evaluation |
| | [rpm] | | | | | | | | | | | | | | | |
| 1 | 111 | 100 | 56 | 49 | 28 | 24 | 22 | 19 | 17 | 11 | 10 | 6 | 4 | 3 | 0.25 | 1 |
| 2 | 222 | 200 | 111 | 98 | 56 | 49 | 44 | 37 | 33 | 22 | 20 | 11 | 8 | 6 | 0.50 | 2 |
| Y | 333 | 300 | 167 | 146 | 83 | 73 | 67 | 56 | 50 | 33 | 30 | 17 | 13 | 9 | 0.75 | 3 |
| 3 | 444 | 400 | 222 | 195 | 111 | 98 | 89 | 74 | 67 | 44 | 40 | 22 | 17 | 13 | 1.00 | 4 |
| Z | 667 | 600 | 333 | 293 | 167 | 146 | 133 | 111 | 100 | 67 | 60 | 33 | 25 | 19 | 1.50 | 6 |
| 4 | 889 | 800 | 444 | 391 | 222 | 195 | 178 | 148 | 133 | 89 | 80 | 44 | 33 | 25 | 2.00 | 8 |
| 5 | 1,333 | 1,200 | 667 | 586 | 333 | 293 | 267 | 222 | 200 | 133 | 120 | 67 | 50 | 38 | 3.00 | 12 |
| 6 | 1,778 | 1,600 | 889 | 781 | 444 | 391 | 356 | 296 | 267 | 178 | 160 | 89 | 67 | 50 | 4.00 | 16 |
| 7 | 2,222 | 2,000 | 1,111 | 977 | 556 | 488 | 444 | 370 | 333 | 222 | 200 | 111 | 83 | 63 | 5.00 | 20 |
| 8 | 2,677 | 2,400 | 1,333 | 1,172 | 667 | 586 | 533 | 444 | 400 | 267 | 240 | 133 | 100 | 75 | 6.00 | 24 |

11.2.2 RIK 4 without Op-Amp

The maximum scanning frequency of the encoder without op-amp amounts to 500 kHz, hence the maximum attainable traversing speed will be derived from that.

C (1 VSS) or K (RS 422) Without interpolation factor

| Value for X | Number of lines (Z) | | | | | | | | | | | | | | Min. counting frequency of the evaluation electronics (in MHz) | |
|-------------|---------------------|--------|--------|--------|-------|-------|-------|-------|-------|-------|--------|--------|--------|--------|--|------------------------|
| | 900 | 1,000 | 1,800 | 2,048 | 3,600 | 4,096 | 4,500 | 5,400 | 6,000 | 9,000 | 10,000 | 18,000 | 24,000 | 32,000 | w/o 4-edge evaluation | with 4-edge evaluation |
| | [rpm] | | | | | | | | | | | | | | | |
| for C: A | 33,333 | 30,000 | 16,667 | 14,648 | 8,333 | 7,324 | 6,667 | 5,556 | 5,000 | 3,333 | 3,000 | 1,667 | 1,250 | 938 | 0.5 | 2 |
| for K: 0 | | | | | | | | | | | | | | | | |

L Interpolation factor = 5

| Value for X | Number of lines (Z) | | | | | | | | | | | | | | Min. counting frequency of the evaluation electronics (in MHz) | |
|-------------|---------------------|--------|--------|--------|-------|-------|-------|-------|-------|-------|--------|--------|--------|--------|--|------------------------|
| | 900 | 1,000 | 1,800 | 2,048 | 3,600 | 4,096 | 4,500 | 5,400 | 6,000 | 9,000 | 10,000 | 18,000 | 24,000 | 32,000 | w/o 4-edge evaluation | with 4-edge evaluation |
| | [rpm] | | | | | | | | | | | | | | | |
| B | 2,222 | 2,000 | 1,111 | 977 | 556 | 488 | 444 | 370 | 333 | 222 | 200 | 111 | 83 | 63 | 0.25 | 1 |
| C | 4,444 | 4,000 | 2,222 | 1,953 | 1,111 | 977 | 889 | 741 | 667 | 444 | 400 | 222 | 167 | 125 | 0.50 | 2 |
| D | 6,667 | 6,000 | 3,333 | 2,930 | 1,667 | 1,465 | 1,333 | 1,111 | 1,000 | 667 | 600 | 333 | 250 | 188 | 0.75 | 3 |
| E | 8,889 | 8,000 | 4,444 | 3,906 | 2,222 | 1,953 | 1,778 | 1,481 | 1,333 | 889 | 800 | 444 | 333 | 250 | 1.00 | 4 |
| G | 13,333 | 12,000 | 6,667 | 5,859 | 3,333 | 2,930 | 2,667 | 2,222 | 2,000 | 1,333 | 1,200 | 667 | 500 | 375 | 1.50 | 6 |
| 4 | 17,778 | 16,000 | 8,889 | 7,813 | 4,444 | 3,906 | 3,556 | 2,963 | 2,667 | 1,778 | 1,600 | 889 | 667 | 500 | 2.00 | 8 |
| 5 | 26,667 | 24,000 | 13,333 | 11,719 | 6,667 | 5,859 | 5,333 | 4,444 | 4,000 | 2,667 | 2,400 | 1,333 | 1,000 | 750 | 3.00 | 12 |
| 6 | 33,333 | 30,000 | 16,667 | 14,648 | 8,333 | 7,324 | 6,667 | 5,556 | 5,000 | 3,333 | 3,000 | 1,667 | 1,250 | 938 | 4.00 | 16 |

M Interpolation factor = 10

| Value for X | Number of lines (Z) | | | | | | | | | | | | | | Min. counting frequency of the evaluation electronics (in MHz) | |
|-------------|---------------------|--------|--------|--------|-------|-------|-------|-------|-------|-------|--------|--------|--------|--------|--|------------------------|
| | 900 | 1,000 | 1,800 | 2,048 | 3,600 | 4,096 | 4,500 | 5,400 | 6,000 | 9,000 | 10,000 | 18,000 | 24,000 | 32,000 | w/o 4-edge evaluation | with 4-edge evaluation |
| | [rpm] | | | | | | | | | | | | | | | |
| B | 1,111 | 1,000 | 556 | 448 | 278 | 244 | 222 | 185 | 167 | 111 | 100 | 56 | 42 | 31 | 0.25 | 1 |
| C | 2,222 | 2,000 | 1,111 | 977 | 556 | 488 | 444 | 370 | 333 | 222 | 200 | 111 | 83 | 63 | 0.50 | 2 |
| D | 3,333 | 3,000 | 1,667 | 1,465 | 833 | 732 | 667 | 556 | 500 | 333 | 300 | 167 | 125 | 94 | 0.75 | 3 |
| E | 4,444 | 4,000 | 2,222 | 1,953 | 1,111 | 977 | 889 | 741 | 667 | 444 | 400 | 222 | 167 | 125 | 1.00 | 4 |
| G | 6,667 | 6,000 | 3,333 | 2,930 | 1,667 | 1,465 | 1,333 | 1,111 | 1,000 | 667 | 600 | 333 | 250 | 188 | 1.50 | 6 |
| R | 8,889 | 8,000 | 4,444 | 3,906 | 2,222 | 1,953 | 1,778 | 1,481 | 1,333 | 889 | 800 | 444 | 333 | 250 | 2.00 | 8 |
| S | 13,333 | 12,000 | 6,667 | 5,859 | 3,333 | 2,930 | 2,667 | 2,222 | 2,000 | 1,333 | 1,200 | 667 | 500 | 375 | 3.00 | 12 |
| 6 | 17,778 | 16,000 | 8,889 | 7,813 | 4,444 | 3,906 | 3,556 | 2,963 | 2,667 | 1,778 | 1,600 | 889 | 667 | 500 | 4.00 | 16 |
| 7 | 22,222 | 20,000 | 11,111 | 9,766 | 5,556 | 4,883 | 4,444 | 3,704 | 3,333 | 2,222 | 2,000 | 1,111 | 833 | 625 | 5.00 | 20 |
| 8 | 26,667 | 24,000 | 13,333 | 11,719 | 6,667 | 5,859 | 5,333 | 4,444 | 4,000 | 2,667 | 2,400 | 1,333 | 1,000 | 750 | 6.00 | 24 |

I Interpolation factor = 25

| Value for X | Number of lines (Z) | | | | | | | | | | | | | | Min. counting frequency of the evaluation electronics (in MHz) | |
|-------------|---------------------|-------|-------|-------|-------|-------|-------|-------|-------|-------|--------|--------|--------|--------|--|------------------------|
| | 900 | 1,000 | 1,800 | 2,048 | 3,600 | 4,096 | 4,500 | 5,400 | 6,000 | 9,000 | 10,000 | 18,000 | 24,000 | 32,000 | w/o 4-edge evaluation | with 4-edge evaluation |
| | [rpm] | | | | | | | | | | | | | | | |
| B | 444 | 400 | 222 | 195 | 111 | 98 | 89 | 74 | 67 | 44 | 40 | 22 | 17 | 13 | 0.25 | 1 |
| C | 889 | 800 | 444 | 391 | 222 | 195 | 178 | 148 | 133 | 89 | 80 | 44 | 33 | 25 | 0.50 | 2 |
| D | 1,333 | 1,200 | 667 | 586 | 333 | 293 | 267 | 222 | 200 | 133 | 120 | 67 | 50 | 38 | 0.75 | 3 |
| E | 1,778 | 1,600 | 889 | 781 | 444 | 391 | 356 | 296 | 267 | 178 | 160 | 89 | 67 | 50 | 1.00 | 4 |
| G | 2,667 | 2,400 | 1,333 | 1,172 | 667 | 586 | 533 | 444 | 400 | 267 | 240 | 133 | 100 | 75 | 1.50 | 6 |
| R | 3,556 | 3,200 | 1,778 | 1,563 | 889 | 781 | 711 | 593 | 533 | 356 | 320 | 178 | 133 | 100 | 2.00 | 8 |
| S | 5,333 | 4,800 | 2,667 | 2,344 | 1,333 | 1,172 | 1,067 | 889 | 800 | 533 | 480 | 267 | 200 | 150 | 3.00 | 12 |
| T | 7,111 | 6,400 | 3,556 | 3,125 | 1,778 | 1,563 | 1,422 | 1,185 | 1,067 | 711 | 640 | 356 | 267 | 200 | 4.00 | 16 |
| U | 8,889 | 8,000 | 4,444 | 3,906 | 2,222 | 1,953 | 1,778 | 1,481 | 1,333 | 889 | 800 | 444 | 333 | 250 | 5.00 | 20 |
| V | 10,667 | 9,600 | 5,333 | 4,688 | 2,677 | 2,344 | 2,133 | 1,778 | 1,600 | 1,067 | 960 | 533 | 400 | 300 | 6.00 | 24 |

N Interpolation factor = 50

| Value for X | Number of lines (Z) | | | | | | | | | | | | | | Min. counting frequency of the evaluation electronics (in MHz) | |
|-------------|---------------------|-------|-------|-------|-------|-------|-------|-------|-------|-------|--------|--------|--------|--------|--|------------------------|
| | 900 | 1,000 | 1,800 | 2,048 | 3,600 | 4,096 | 4,500 | 5,400 | 6,000 | 9,000 | 10,000 | 18,000 | 24,000 | 32,000 | w/o 4-edge evaluation | with 4-edge evaluation |
| | [rpm] | | | | | | | | | | | | | | | |
| B | 222 | 200 | 111 | 98 | 56 | 49 | 44 | 37 | 33 | 22 | 20 | 11 | 8 | 6 | 0.25 | 1 |
| C | 444 | 400 | 222 | 195 | 111 | 98 | 89 | 74 | 67 | 44 | 40 | 22 | 17 | 13 | 0.50 | 2 |
| D | 667 | 600 | 333 | 293 | 167 | 146 | 133 | 111 | 100 | 67 | 60 | 33 | 25 | 19 | 0.75 | 3 |
| E | 889 | 800 | 444 | 391 | 222 | 195 | 178 | 148 | 133 | 89 | 80 | 44 | 33 | 25 | 1.00 | 4 |
| G | 1,333 | 1,200 | 667 | 586 | 333 | 293 | 267 | 222 | 200 | 133 | 120 | 67 | 50 | 38 | 1.50 | 6 |
| R | 1,778 | 1,600 | 889 | 781 | 444 | 391 | 356 | 296 | 267 | 178 | 160 | 89 | 67 | 50 | 2.00 | 8 |
| S | 2,667 | 2,400 | 1,333 | 1,172 | 667 | 586 | 533 | 444 | 400 | 267 | 240 | 133 | 100 | 75 | 3.00 | 12 |
| T | 3,556 | 3,200 | 1,778 | 1,563 | 889 | 781 | 711 | 593 | 533 | 356 | 320 | 178 | 133 | 100 | 4.00 | 16 |
| U | 4,444 | 4,000 | 2,222 | 1,953 | 1,111 | 977 | 889 | 741 | 667 | 444 | 400 | 222 | 167 | 125 | 5.00 | 20 |
| V | 5,333 | 4,800 | 2,677 | 2,344 | 1,333 | 1,172 | 1,067 | 889 | 800 | 533 | 480 | 267 | 200 | 150 | 6.00 | 24 |

P Interpolation factor = 100

| Value for X | Number of lines (Z) | | | | | | | | | | | | | | Min. counting frequency of the evaluation electronics (in MHz) | |
|-------------|---------------------|-------|-------|-------|-------|-------|-------|-------|-------|-------|--------|--------|--------|--------|--|------------------------|
| | 900 | 1,000 | 1,800 | 2,048 | 3,600 | 4,096 | 4,500 | 5,400 | 6,000 | 9,000 | 10,000 | 18,000 | 24,000 | 32,000 | w/o 4-edge evaluation | with 4-edge evaluation |
| | [rpm] | | | | | | | | | | | | | | | |
| B | 111 | 100 | 56 | 49 | 28 | 24 | 22 | 19 | 17 | 11 | 10 | 6 | 4 | 3 | 0.25 | 1 |
| C | 222 | 200 | 111 | 98 | 56 | 49 | 44 | 37 | 33 | 22 | 20 | 11 | 8 | 6 | 0.50 | 2 |
| D | 333 | 300 | 167 | 146 | 83 | 73 | 67 | 56 | 50 | 33 | 30 | 17 | 13 | 9 | 0.75 | 3 |
| E | 444 | 400 | 222 | 195 | 111 | 98 | 89 | 74 | 67 | 44 | 40 | 22 | 17 | 13 | 1.00 | 4 |
| G | 667 | 600 | 333 | 293 | 167 | 146 | 133 | 111 | 100 | 67 | 60 | 33 | 25 | 19 | 1.50 | 6 |
| R | 889 | 800 | 444 | 391 | 222 | 195 | 178 | 148 | 133 | 89 | 80 | 44 | 33 | 25 | 2.00 | 8 |
| S | 1,333 | 1,200 | 667 | 586 | 333 | 293 | 267 | 222 | 200 | 133 | 120 | 67 | 50 | 38 | 3.00 | 12 |
| T | 1,778 | 1,600 | 889 | 781 | 444 | 391 | 356 | 296 | 267 | 178 | 160 | 89 | 67 | 50 | 4.00 | 16 |
| U | 2,222 | 2,000 | 1,111 | 977 | 556 | 488 | 444 | 370 | 333 | 222 | 200 | 111 | 83 | 63 | 5.00 | 20 |
| V | 2,677 | 2,400 | 1,333 | 1,172 | 667 | 586 | 533 | 444 | 400 | 267 | 240 | 133 | 100 | 75 | 6.00 | 24 |

11.3 Graduated Disk

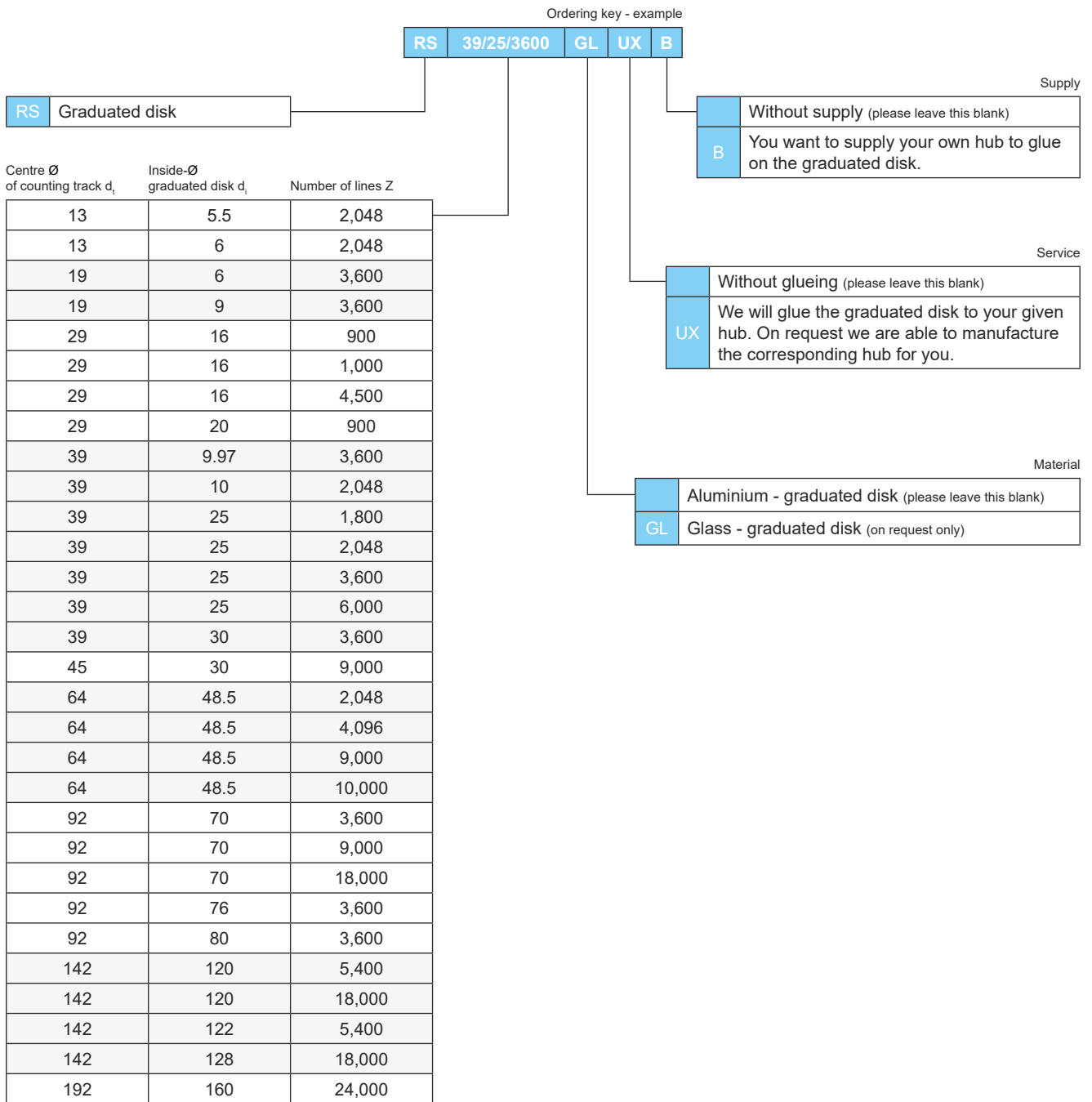

(other sizes on request)

NOTE

Deviations from the standard configurations listed here are possible in principle. We would be happy to work with you to develop your individual solution. Simply get in touch with your local contact person. You will find a corresponding contact list on our website under "Contact".

11.4 ADJUSTMENT TOOL

| Name | Scope of delivery / Description | Order-no. |
|-----------------|--|-----------|
| ADJUSTMENT TOOL | <ul style="list-style-type: none"> • ADJUSTMENT TOOL black box • Diagnostic cable to connect the measuring system • USB cable to connect a PC • USB - D-SUB - adapter cable (15-pin) • Exchangeable 8-pin plug connectors | 344220-33 |

Optional Single Components

| Name | Description | Order-no. |
|--------------------------------------|--|-----------|
| EPIFLEX software - USB flash drive | External flash drive with saved EPIFLEX software | 686802-02 |
| USB - D-SUB - adapter cable (15-pin) | to supply the measuring system with voltage via PC | 341693-0M |
| 8-pin plug connector | to connect the diagnostic cable to the diagnostic socket | 348958-01 |



USB - D-SUB - adapter cable (15-pin)

Image 25

Required components (not included):

- PC with OS Windows 7, 8, 10 (32 or 64 bit)



NUMERIK JENA GmbH
Im Semmicht 4
07751 Jena • Germany
info@numerikjena.com
www.numerikjena.com

