

## Index

<b>1.</b>	<b>Features and Applications</b>	<b>4</b>
<b>2.</b>	<b>Safety</b>	<b>5</b>
2.1	General Information	5
2.2	Notes on Legal Requirements	6
2.3	Environmental Protection and Disposal	6
2.4	Notes on Transport, Storage and Handling	7
2.5	Notes on Operation	8
2.6	Notes on Maintenance	8
<b>3.</b>	<b>Setup of the Rotary Kit Encoder</b>	<b>9</b>
3.1	Setup with Signal Processing in a D-Sub Connector	9
3.2	Setup with Signal Processing on a Connector PCB	9
3.3	Setup without Signal Processing	10
<b>4.</b>	<b>Graduated Disks</b>	<b>11</b>
4.1	Graduated Disks - Types	12
<b>5.</b>	<b>Scanning Head</b>	<b>13</b>
<b>6.</b>	<b>Technical Data</b>	<b>14</b>
6.1	Resolution and Accuracy (Definition)	14
6.2	Mechanical Data	15
6.3	Calculation of the Attainable Speed of Rotation	15
6.4	Electrical Data	16
6.5	Switch-On Behaviour	16
6.6	Ambient Conditions	17
6.7	Cable	17
6.8	Connector PCB	18
6.8.1	Type 1 with Signal Processing	18
6.8.2	Type 2 with Signal Processing	18
6.8.3	Type 2 without Signal Processing	19
6.9	Dimensions Connector Cable with Open Output	19
6.10	Connector Variants	20
6.11	PIN Assignment	21
6.12	PIN Assignment for Connector PCB $X_1$	22
6.13	PIN Assignment for JST Miniature Connector $X_2$ and $X_3$	22
6.14	Electromagnetic Compatibility (EMC)	23
6.15	Shielding Concepts	24
6.16	Voltage Output 1 $V_{PP}$	25
6.17	Square-Wave Output RS-422	26
6.18	Online Compensation (Offset and Amplitude Control)	27

<b>7.</b>	<b>General Mounting Instructions .....</b>	<b>28</b>
7.1	Delivery Contents .....	28
7.2	Encoder Mounting Position .....	28
7.3	Mounting of the Encoder System .....	29
7.3.1	Scanning Head with Frame .....	29
7.3.2	Dimensions and Mounting Tolerances - with Frame .....	30
7.3.3	Scanning Head without Frame .....	31
7.3.4	Dimensions and Mounting Tolerances - without Frame .....	32
7.4	Mounting of the Graduated Disk .....	33
7.5	Mounting of the Scanning Head .....	37
<b>8.</b>	<b>Signal Adjustment with ADJUSTMENT TOOL .....</b>	<b>38</b>
8.1	Functions of the ADJUSTMENT TOOL .....	38
8.2	Dynamic Offset and Amplitude Control (Online Compensation) .....	38
8.3	Scope of Delivery .....	38
8.4	EPIFLEX Software .....	39
<b>9.</b>	<b>Cleaning .....</b>	<b>40</b>
<b>10.</b>	<b>Troubleshooting .....</b>	<b>41</b>
<b>11.</b>	<b>Ordering Key .....</b>	<b>42</b>
11.1	Scanning Head .....	42
11.2	Speed Chart for RIK Series .....	43
11.2.1	Kit R4 with Op-Amp .....	43
11.2.2	Kit R4 without Op-Amp .....	45
11.3	Graduated Disk .....	47
11.4	ADJUSTMENT TOOL .....	48

## 1. Features and Applications

Position encoders in drive systems have to meet high and controversial demands. The demands opposing each other are high accuracy and resolution on the one hand and low mass, small dimensions and high measuring speed on the other hand.

- The concentration of multiple axes in rotation in very tight spaces, such as in semiconductor-producing machines, requires the miniaturization of the drives, bearings and encoders.
- High machining speeds and therefore high accelerations make low masses of the components in motion essential.

The optical RIK 4 incremental encoders from NUMERIK JENA are equipped with features which are supposed to fulfill these high requirements in an ideal way.

- Due to an interpolation circuitry, a resolutions down to 0.135 arc seconds is possible without any additional electronics.
- The permissible speed of rotation for a sinusoidal signal output amounts up to 22,000 rpm.
- The short-range position errors (interpolation errors) were significantly reduced by introducing an electronic compensation of amplitude and offset deviations of the coarse signals. This compensation functions without following error in all velocity ranges.
- The Kit encoder series was especially developed for customized applications and offers a large variety of configuration possibilities.

Additional features:

- Compact size and ultra flat design
- Customizable sensor frames and housings available
- Large mounting tolerances
- Low mass moment of inertia of the graduated disk
- High measuring speed
- Online compensation (dynamic offset and amplitude control)
- Signal interpolation up to 100-times
- Possibility of electronic signal adjustment (signal optimization after mounting)

**Applications:**

- Automation technology
- Rotary axes
- Drive systems, especially direct drives and torque motors
- Instruments and machines used in semiconductor industry
- Robot and handling technology
- High-precision engineering
- Metrology
- Medical technology

## 2. Safety

### 2.1 General Information

- Make sure to familiarize yourself thoroughly with the contents of these installation instructions before installing and starting up the encoder!
- Please contact the support of NUMERIK JENA GmbH or an authorized representation for further information. Please visit the NUMERIK JENA website to get the contact information.
- NUMERIK JENA GmbH is not liable for damages caused by unauthorized handling of the encoders. Any unauthorized handling leads to forfeiture of all warranty claims.
- The encoders are guaranteed to function if the mounting and operating conditions are maintained as stated in these mounting instructions.
- Make sure to follow the right sequence of the mounting steps during mounting.
- NUMERIK JENA GmbH does not assume any liability for any damages or operating errors caused by incorrect installation or operation.
- The stated tolerances must be maintained in order to achieve the accuracies listed in the specifications!
- If the machine tolerances exceed the tolerances stated in the mounting instructions, errors can occur in both the operation and during measuring. NUMERIK JENA GmbH assumes no liability for this.
- Please refer to the operating manuals and safety instructions included with the devices to ensure the reliable operation of the encoder systems, especially pertaining to:
  - Auxiliary electronic units
  - Counters
  - Displays
  - Controllers
  - Encoders
  - Base mechanical devices (machine tools)
- Connect NUMERIK JENA encoders only to subsequent electronics whose power supply is generated from PELV systems (EN 50178).
- Please pay attention to the safety instructions and warning symbols!



Danger to the device or to the function of the device!



Pull the plug!



Highly inflammable!

## 2.2 Notes on Legal Requirements

- The NUMERIK JENA encoders conform to EC standards and carry the CE mark.
- NUMERIK JENA encoders fulfill the requirements of the (German) Product Safety Act (ProdSG) from November 8<sup>th</sup>, 2011.
- NUMERIK JENA encoders fulfill the requirements of standard IEC 61010-1 only if the power is supplied from a secondary circuit with current limitation as per IEC 61010 (3rd Ed.), Section 9.4 or with power limitation as per IEC 62368-1 (2nd Ed.), section 6.2.2.5 PS2 or from a Class 2 secondary circuit as specified in UL1310.\*
- This user manual supersedes all previous editions, which thereby become invalid. The basis for ordering from NUMERIK JENA is always the user manual edition valid when the contract is made.
- Standards (ISO, EN, etc.) apply only where explicitly stated in the user manual.
- NUMERIK JENA has tested its products to ensure the use of non-hazardous materials in accordance with the European Directives 2011/65/EU (RoHS). The EU Declaration of Conformity can be requested at the following web address:

**<https://www.numerikjena.com/numerikjena/contact/>**

## 2.3 Environmental Protection and Disposal

Environmental damage due to incorrect disposal of the product, accessories or peripherals!

- Do not dispose in domestic waste.
- Dispose only by authorized collection points. Electrical waste and electronic components are subject to special-waste regulations.
- Observe the applicable country-specific regulations.

More detailed information on legal regulations can be obtained from competent authorities.

\* In place of IEC 61010-1 (3rdEd.), Section 9.4, the corresponding sections of standards DIN EN 61010-1, EN61010-1, UL 61010-1 and CAN/CSA-C22.2 No. 61010-1 can be applied and in place of IEC 62368-1 (2nd Ed.), section 6.2.2.5 PS2 the corresponding sections of standards DIN EN62368-1, EN62368-1, UL62368-1, CAN/CSA-C22.2 No. 62368-1 can be applied.

## 2.4 Notes on Transport, Storage and Handling



- Please use the original packaging for transportation and storage only!
- After receiving the measuring system please check the packaging and the seal for damages first! Once opened, scratches or contaminations on the graduated disk cannot be complained anymore.
- Handle the graduated disk carefully! Its surface is sensitive to scratching.
- Small surface errors evident at the time of shipping are due to the production process. These errors are no indication for a quality defect and do not affect the encoder's functionality.
- Handle the aluminum disk carefully please and protect it especially against mechanical deformation. Unevenness of the disk influences the correct operation of the encoder.



Image 1

## 2.5 Notes on Operation



- Do not connect or disconnect plugs if the power is on!
- Only operate the encoder with the supply voltage stated in this product data sheet.
- Connect NUMERIK JENA encoders only to subsequent electronics whose power supply is generated from PELV systems (EN 50178).
- Comply with applicable PIN assignment if auxiliary electronic units are connected (e.g. controller or display)!
- Integrate exposed encoders in instruments, devices or machines in such a way that these are protected against contamination.
- Protect the graduated disk against mechanical damage.
- Protect the scanning head against shock, impact and humidity.

## 2.6 Notes on Maintenance



- The encoder requires no maintenance whatsoever, but must be cleaned occasionally, depending on the ambient conditions.
- Modifications and repairs of the encoder may only be carried out by NUMERIK JENA GmbH or appropriately authorized persons.
- NUMERIK JENA GmbH is not liable for damages caused by unauthorized handling of the encoder. All warranty claims are forfeited by unauthorized handling.
- Exposed measuring systems are sensitive to contamination, especially the disk surface and the scanning windows for the counting and reference tracks on the scanning head.
- Particularly critical are rough and irregular contamination and deposits (e.g. oil, grease or water).
- The user has to protect the encoder from contamination by way of appropriate design measures.
- **When cleaning the encoder, ensure that no solvent flows under the graduated disk!**
- **When cleaning the components, ensure that the scanning window and graduated disk are not scratched by any deposited particles!**
- **Please also pay attention to the notes in chapter 9 „Cleaning“.**

### 3. Setup of the Rotary Kit Encoder

#### 3.1 Setup with Signal Processing in a D-Sub Connector

This setup consists of the following components:

- EPIFLEX sensor module glued into a very flat frame
- Graduated disk with counting track and index
- Connector PCB to connect flex cable with round cable of the connector
- Connector with integrated electronics ( $1 V_{PP}$  or RS-422) and cable

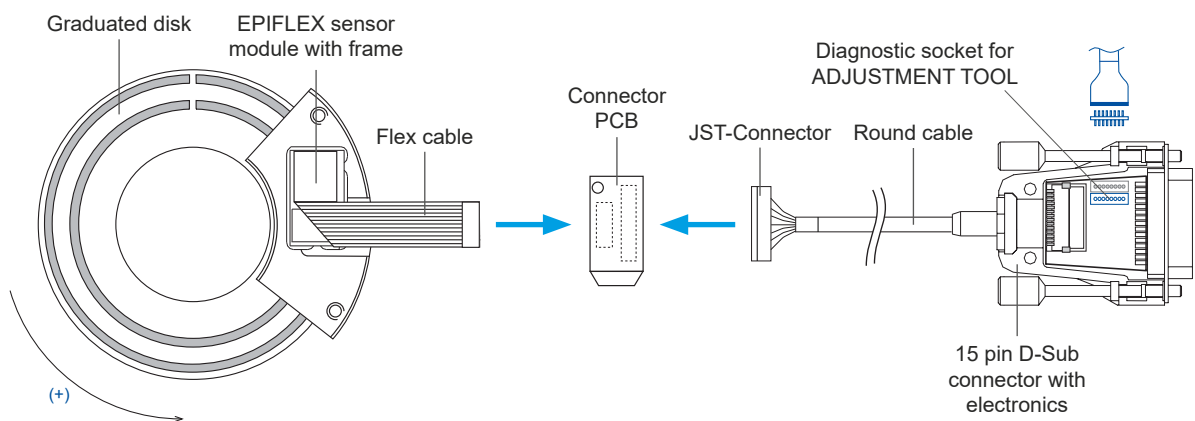

Image 2

#### 3.2 Setup with Signal Processing on a Connector PCB

This setup consists of the following components:

- EPIFLEX sensor module glued into a very flat frame
- Graduated disk with counting track and index
- Connector PCB with integrated electronics ( $1 V_{PP}$  or RS-422)
- Connector with cable

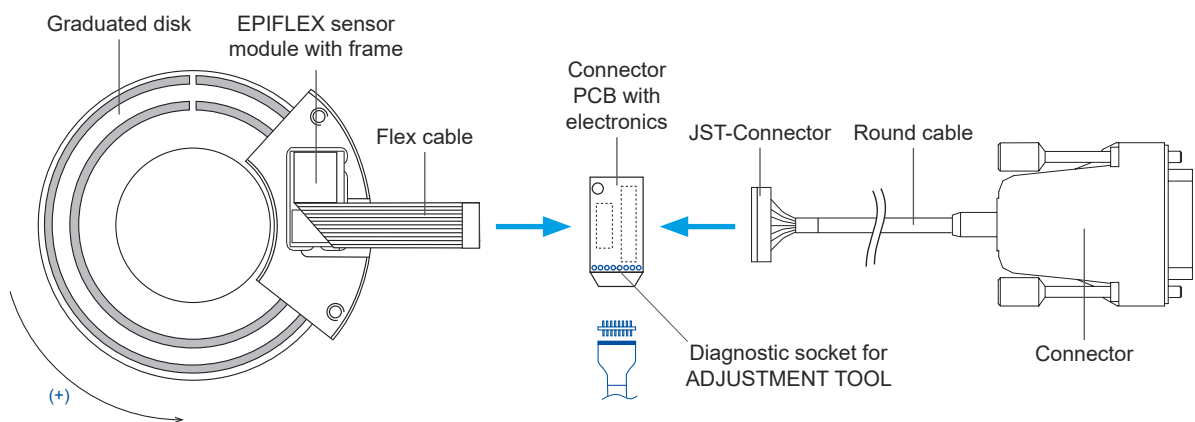

Image 3

### 3.3 Setup without Signal Processing

This setup consists of the following components:

- EPIFLEX sensor module glued into a very flat frame
- Graduated disk with counting track and index

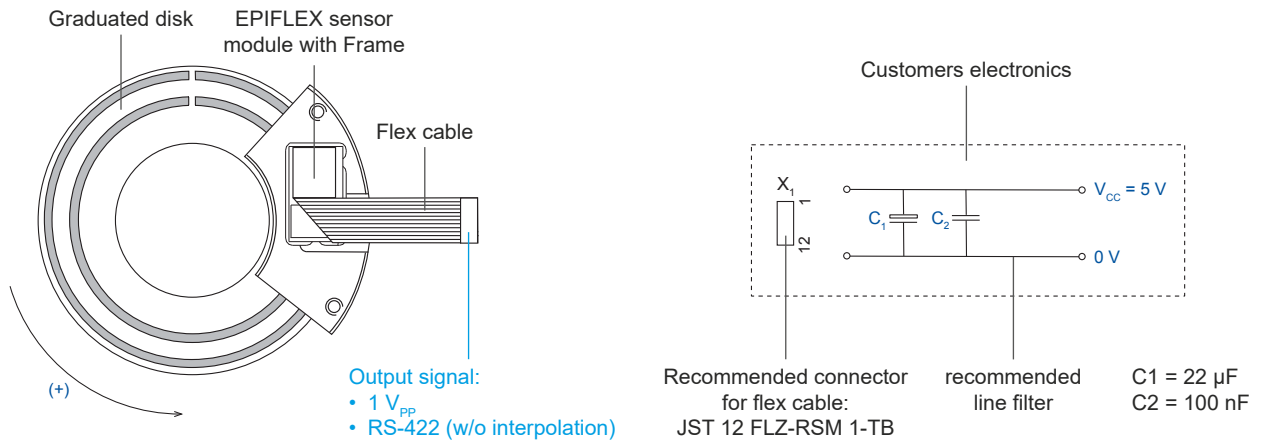

Image 4

**Attention:** To adjust this Kit R4 setup electronically it is necessary to integrate the following circuitry. The connection between the ADJUSTMENT TOOL and the PCB will be done with an 8 pin plug connector (included with the ADJUSTMENT TOOL).

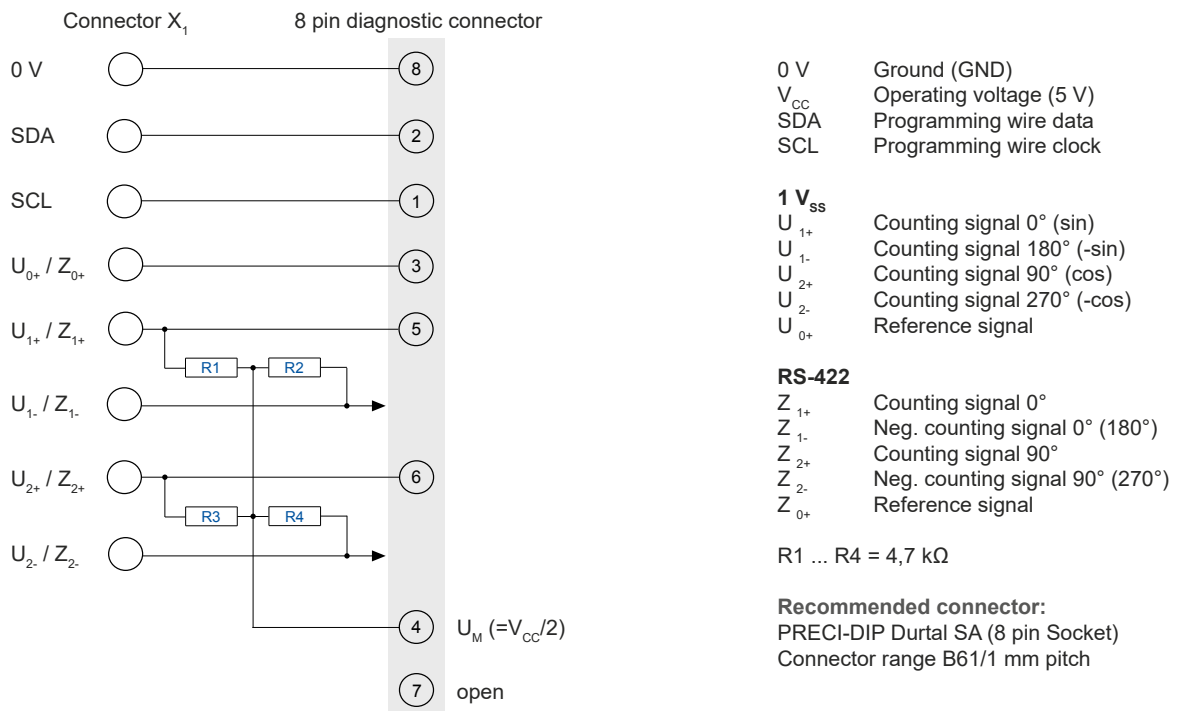

Image 5

#### 4. Graduated Disks

The graduated disks from NUMERIK JENA are available in different sizes and versions. Hereto we have a big selection of obtainable graduated disks in supply but on request we also manufacture at customer's option.

Our graduated disks are made of an aluminium alloy. They are also available in glass on request.

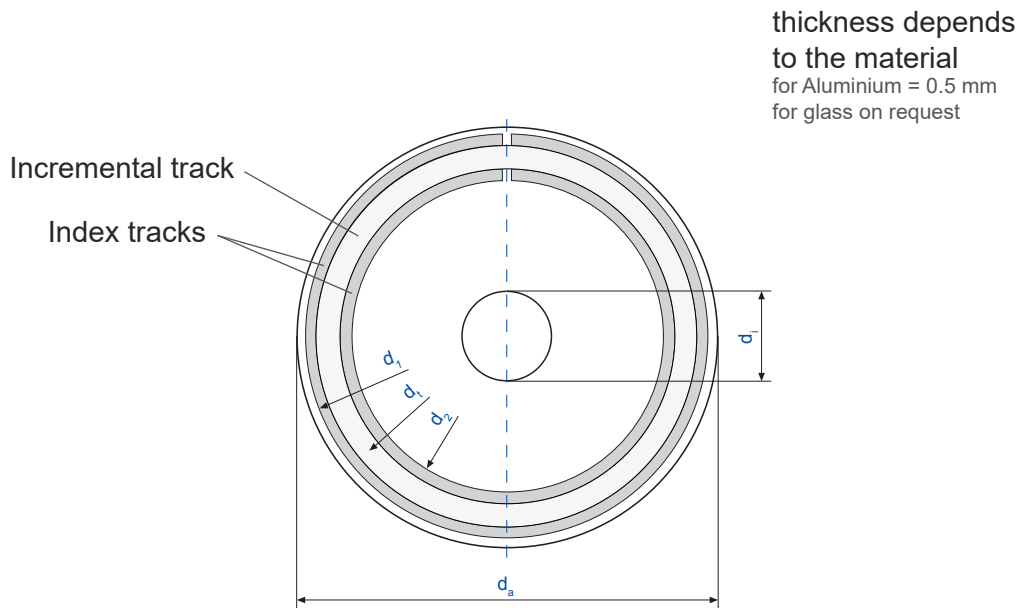

Image 6

$d_i$	Inside diameter of the graduated disk
$d_a$	Outside diameter of the graduated disk
$d_t$	Center diameter of the incremental track
$d_1$	Outside diameter of the index track
$d_2$	Inside diameter of the index track
Z	Number of lines of the graduated disk

## 4.1 Graduated Disks - Types

Type	$d_i$ [mm]	$d_a$ [mm]	$d_t$ [mm]	$d_1$ [mm]	$d_2$ [mm]	$d_L$ [mm]	$d$ [mm]	Z
RS 13/5.5/2048	5.5 + 0.03	19 <sup>0</sup> <sub>-0.5</sub>	13	18	8	-	-	2,048
RS 13/6/2048	6 + 0.03	19 <sup>0</sup> <sub>-0.5</sub>	13	18	8	-	-	2,048
RS 19/6/3600	6 + 0.1	26 <sup>-0.2</sup> <sub>-0.5</sub>	19	24	14	-	-	3,600
RS 19/9/3600	9 + 0.1	26 <sup>-0.2</sup> <sub>-0.5</sub>	19	24	14	-	-	3,600
RS 29/16/900	16 + 0.1	36 <sup>-0.2</sup> <sub>-0.5</sub>	29	34	24	-	-	900
RS 29/16/1000	16 + 0.1	36 <sup>-0.2</sup> <sub>-0.5</sub>	29	34	24	-	-	1,000
RS 29/16/4500	16 + 0.1	36 <sup>-0.2</sup> <sub>-0.5</sub>	29	34	24	-	-	4,500
RS 29/20/900	20 + 0.1	36 <sup>-0.2</sup> <sub>-0.5</sub>	29	34	24	-	-	900
RS 39/9,97/3600	25 + 0.1	46 <sup>-0.2</sup> <sub>-0.5</sub>	39	44	34	-	-	3,600
RS 39/25/1800	25 + 0.1	46 <sup>-0.2</sup> <sub>-0.5</sub>	39	44	34	-	-	1,800
RS 39/25/2048	25 + 0.1	46 <sup>-0.2</sup> <sub>-0.5</sub>	39	44	34	-	-	2,048
RS 39/25/3600	25 + 0.1	46 <sup>-0.2</sup> <sub>-0.5</sub>	39	44	34	-	-	3,600
RS 39/25/6000	25 + 0.1	46 <sup>-0.2</sup> <sub>-0.5</sub>	39	44	34	-	-	6,000
RS 39/30/3600	30 + 0.1	46 <sup>-0.2</sup> <sub>-0.5</sub>	39	44	34	-	-	3,600
RS 45/30/9000	30 + 0.1	54 <sup>-0.2</sup> <sub>-0.5</sub>	45	50	40	-	-	9,000
RS 64/48,5/2048	48,5 + 0.1	71 <sup>-0.2</sup> <sub>-0.5</sub>	64	69	59	-	-	2,048
RS 64/48,5/4096	48,5 + 0.1	71 <sup>-0.2</sup> <sub>-0.5</sub>	64	69	59	-	-	4,096
RS 64/48,5/9000	48,5 + 0.1	71 <sup>-0.2</sup> <sub>-0.5</sub>	64	69	59	-	-	9,000
RS 64/48,5/10000	48,5 + 0.1	71 <sup>-0.2</sup> <sub>-0.5</sub>	64	69	59	-	-	10,000
RS 92/70/3600	70 + 0.1	100 <sup>-0.2</sup> <sub>-0.5</sub>	92	97	87	-	-	3,600
RS 92/70/9000	70 + 0.1	100 <sup>-0.2</sup> <sub>-0.5</sub>	92	97	87	-	-	9,000
RS 92/70/18000	70 + 0.1	100 <sup>-0.2</sup> <sub>-0.5</sub>	92	97	87	-	-	18,000
RS 92/76/3600	76 + 0.1	100 <sup>-0.2</sup> <sub>-0.5</sub>	92	97	87	-	-	3,600
RS 92/80/3600	80 + 0.1	105 <sup>-0.2</sup> <sub>-0.5</sub>	92	97	87	-	-	3,600
RS 142/120/5400	120 + 0.2	150 <sup>-0.2</sup> <sub>-0.5</sub>	142	147	137	-	-	5,400
RS 142/120/18000	120 + 0.2	150 <sup>-0.2</sup> <sub>-0.5</sub>	142	147	137	-	-	18,000
RS 142/122/5400	122 + 0.2	150 <sup>-0.2</sup> <sub>-0.5</sub>	142	147	137	-	-	5,400
RS 142/128/18000	128 + 0.2	150 <sup>-0.2</sup> <sub>-0.5</sub>	142	147	137	-	-	18,000
RS 192/160/24000	160 + 0.2	199 <sup>-0.2</sup> <sub>-0.5</sub>	192	197	187	-	-	24,000

(other sizes on request)

Chart 1

## 5. Scanning Head

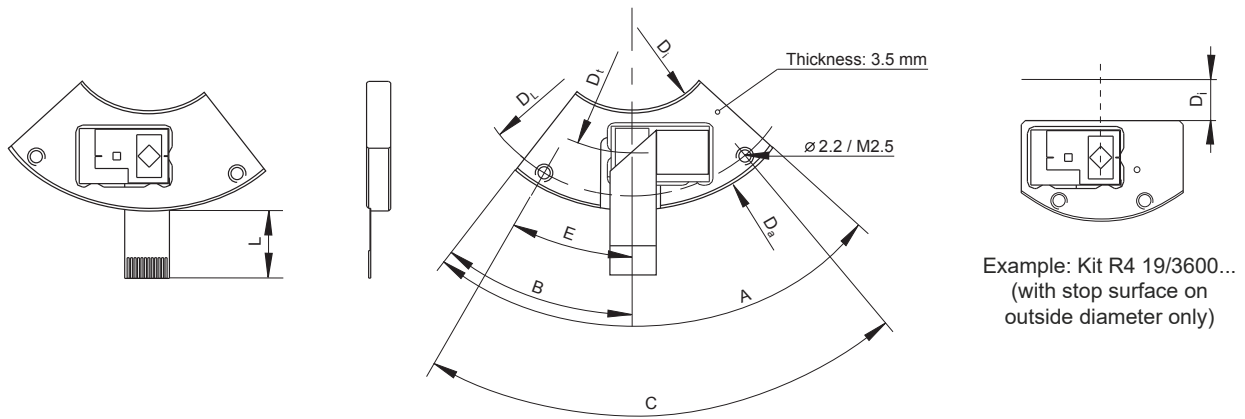

Image 7

Type	$D_a$ [mm]	$D_t$ [mm]	$D_i$ [mm]	$D_L$ [mm]	A	B	C	E
MF 13	-	13	2,5*	-	-	-	-	-
MF 19	38 <sub>h6</sub>	19	4*	34 ±0.1	24 mm	12 mm	44°	22°
MF 29	45 <sub>h6</sub>	29	16 <sup>H6</sup>	41 ±0.1	120°	60°	82°	34°
MF 39	55 <sub>h6</sub>	39	26 <sup>H6</sup>	51 ±0.1	86°	38°	70°	30°
MF 45	64 <sub>h6</sub>	45	34 <sup>H6</sup>	60 ±0.1	66°	33°	56°	28°
MF 64	82 <sub>h6</sub>	64	50.8 <sup>H6</sup>	77 ±0.1	54°	27°	44°	22°
MF 92	110 <sub>h6</sub>	92	78 <sup>H6</sup>	106 ±0.1	40°	20°	34°	17°
MF 142	160 <sub>h6</sub>	142	126 <sup>H6</sup>	156 ±0.1	26°	13°	22°	11°
MF 192	210 <sub>h6</sub>	192	180 <sup>H6</sup>	206 ±0.1	15°	7.5°	10°	5°

\* distance to the center, do not use as datum dimension

Chart 2

$D_a$  Outside diameter of the scanning head  
 $D_i$  Inside diameter of the scanning head  
 $L$  Length of the flex cable (35 mm, 55 mm or 75 mm)

$D_t$  Center diameter of the counting track  
 $D_L$  Hole spacing of borings for mounting screws

## 6. Technical Data

### 6.1 Resolution and Accuracy (Definition)

Basically one has to differentiate between the resolution and the accuracy of a measuring system. The two parameters are not directly interdependent and may differ from each other.

#### Resolution

Resolution "A" is defined as the smallest angular value that is still detected by the evaluating electronics (display, control) when the graduated disk is turned relative to the scanning head. The resolution can be calculated using the following formula:

$$A = Z \cdot i \cdot N \quad [\text{Increments/Revolution}]$$

$$A = \frac{360^\circ}{Z \cdot i \cdot N} \quad [\text{Degrees}]$$

Z	Number of lines (graduated disk)
i	Interpolation factor of the evaluation electronics (5-times, 10-times, 25-times, 50-times or 100-times)
N	Factor for evaluation mode (counter) N = 1 for single-edge evaluation N = 4 for 4-edge evaluation

#### Accuracy

Accuracy (extremes of direction deviations) is affected by

- graduation errors of the graduated disk
- eccentricity of the graduation relative to the axis bearing
- radial eccentricity of the axis bearing
- deviations in the positions of the graduated disk and the scanning head (mounting tolerances)
- interpolation error in signal processing

The accuracy is largely determined by the eccentricity of the graduation relative to the axis bearing and the radial eccentricity of the axis bearing. The error resulting from these factors is calculated using the following formula:

$$\Delta\phi = \pm 412 \frac{e}{D}$$

$\Delta\phi$	Angular error [Arc seconds]
e	Eccentricity of the graduation relative to the rotational axis including the radial eccentricity of the axis bearing [ $\mu\text{m}$ ]
D	Graduation diameter of the graduated disk [mm]

## 6.2 Mechanical Data

Kit R4	
Weight of scan head (w/o cable)	3 - 6 g
Number of counting pulses / rev. (with signal interpolation and 4-edge evaluation)	up to 9,600,000
Available diameter of graduated disks (Ø of graduation) and their weight	<ul style="list-style-type: none"> <li>• 13 mm / 0.4 g</li> <li>• 19 mm / 0.6 g</li> <li>• 29 mm / 1.1 g</li> <li>• 39 mm / 1.6 g</li> <li>• 45 mm / 1.9 g</li> <li>• 64 mm / 2.7 g</li> <li>• 92 mm / 5.4 g</li> <li>• 142 mm / 8.2 g</li> <li>• 192 mm / 15.2 g</li> </ul>

Chart 3

## 6.3 Calculation of the Attainable Speed of Rotation

The maximum attainable speed of rotation of the encoder is determined by the maximum output frequency of the interpolator and/or the maximum counting frequency of the operator's evaluation electronics.

In order to avoid counting errors, the interpolator's output frequency is matched to the counting frequency of the operator's evaluation electronics.

This adaptation is possible in discrete frequency steps.

The maximum attainable speed of rotation ( $n_{\max}$ ) is calculated according to the following formula:

$$n_{\max} = \frac{f \cdot 60}{i \cdot SF \cdot 4 \cdot Z} \quad [\text{rpm}]$$

f	Clock frequency of the counter [Hz]
i	Interpolation factor (5-times, 10-times, 25-times, 50-times or 100-times)
SF	Safety factor = 1.5
4	4-edge evaluation
Z	Number of lines (Graduated disk)

## 6.4 Electrical Data

Kit R4	
Scanning frequency	max. 500 kHz
Output Interfaces	
Voltage output	1 V <sub>PP</sub>
Square wave output	RS-422 with interpolation up to 100-times
Supply voltage	5 V ±10%
Current consumption for sensors with sensor amplifier „SV 3“	
Voltage output	≤80 mA*
Square wave output	≤210 mA*
Current consumption for sensors with sensor amplifier „SV 4“	
Voltage output	≤50 mA*
Square wave output	≤150 mA*
Cable	
Cable diameter	3.7 mm oder 5.1 mm (double shielded)
Permissible bending radius	<ul style="list-style-type: none"> <li>occasional flexing ~8 mm</li> <li>constant flexing ~40 mm</li> </ul>
Length from scan head to the D-Sub connector	3 m (standard: 0.3 m, 0.5 m, 1.0 m, 1.5 m, 2.0 m, 3.0 m)
Length from D-Sub connector to the controller	max. 100 m (The necessary supply voltage must be ensured!)

\* with 120 Ω load resistance

Chart 4

## 6.5 Switch-On Behaviour

During power-up procedure of the encoder system the level of power voltage and signal lines must be below 250 mV.



If the encoder system will be powered-up at a residual voltage between a range of 250 and 400 mV, internal sensor parameter will not set correctly. This will lead to incorrect encoder signals.

This behaviour has to be observed especially during reset routines of controllers.

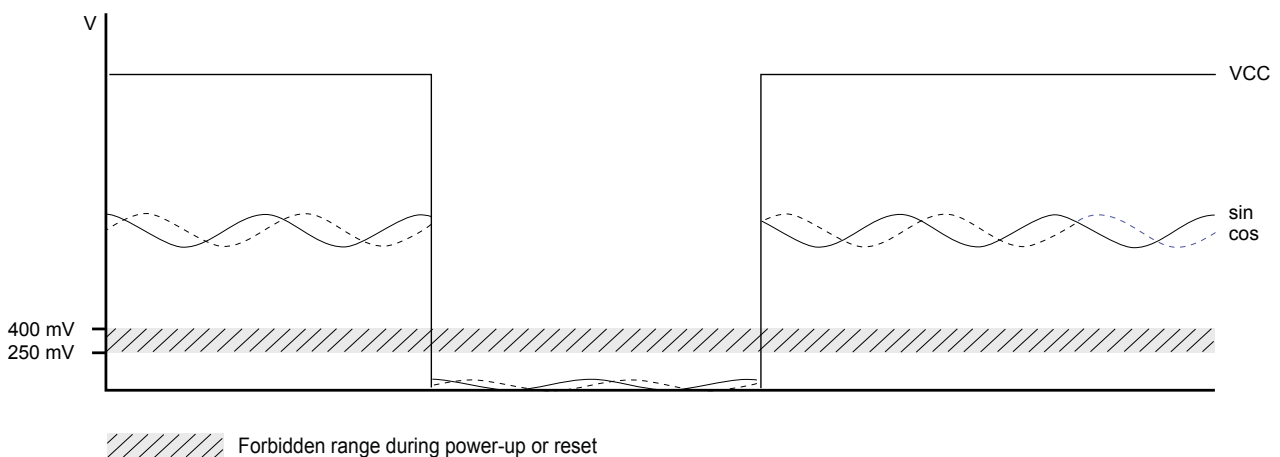

Image 8

## 6.6 Ambient Conditions

	Kit R4
Operating temperature range	0°C to +55°C (+32°F to +131°F)
Storage temperature range	-20°C to +70°C (-4°F to +158°F)
Vibration (50 Hz ... 2,000 Hz)	≤200 ms <sup>-2</sup> (20 g)
Shock (11 ms)	≤400 ms <sup>-2</sup> (40 g)
Humidity	≤93% relative humidity (no condensation forming)

Chart 5

## 6.7 Cable

### Scanning Head Cable (connection cable from connector PCB to D-Sub connector)

- Provide a strain relief for the cable near the connector PCB.
- The encoder cables and connecting cables must be laid away from sources of interference (e.g. mains cables, fuses, motors, magnetic valves or power supplies). Normally a distance of ≥100 mm will be sufficient.
- Install the cable in a way that it cannot be damaged by the rotating hub. Please pay attention to the permissible bending radius (see also point 6.4!

### Extension Cable (connection cable from D-Sub connector to controller)

- Use preferably original extension cables made by NUMERIK JENA. This guarantees an optimum compatibility with the encoders and ensures a maximum protection against electromagnetic interferences.
- Please consult the technical support of NUMERIK JENA before using selfmanufactured extension cables.
- Do not install any other signal lines in the encoder cable!

## 6.8 Connector PCB

### 6.8.1 Type 1 with Signal Processing

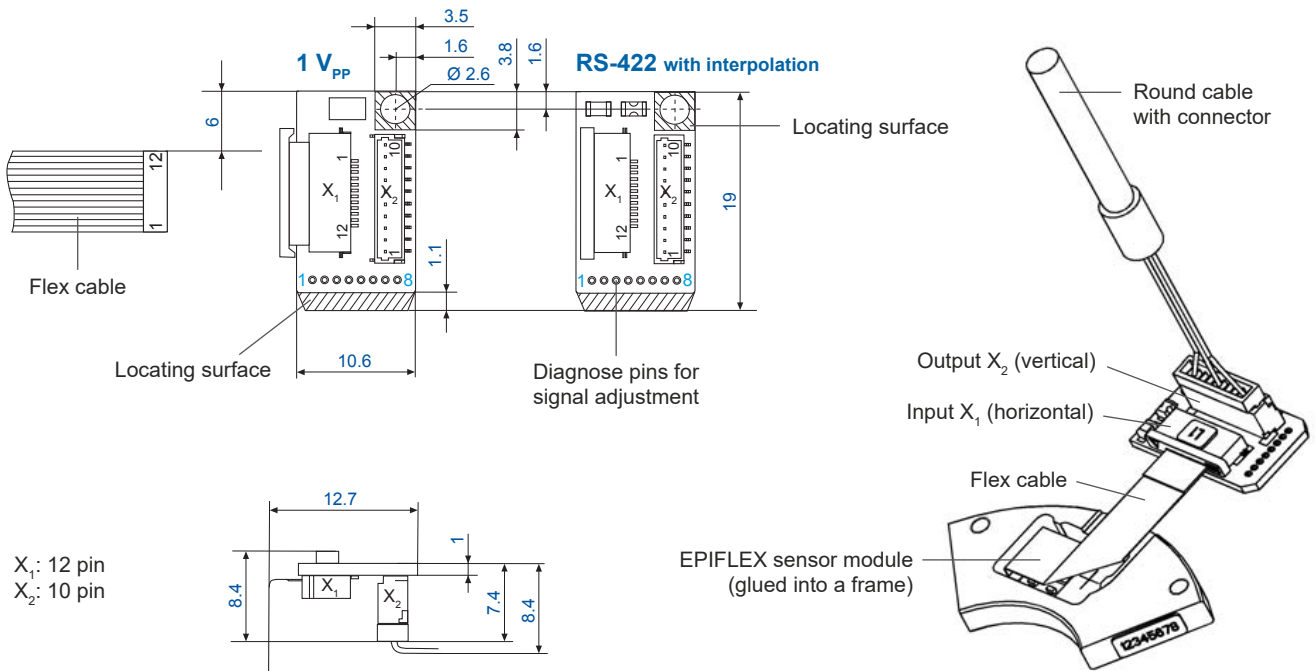

Image 9

### 6.8.2 Type 2 with Signal Processing

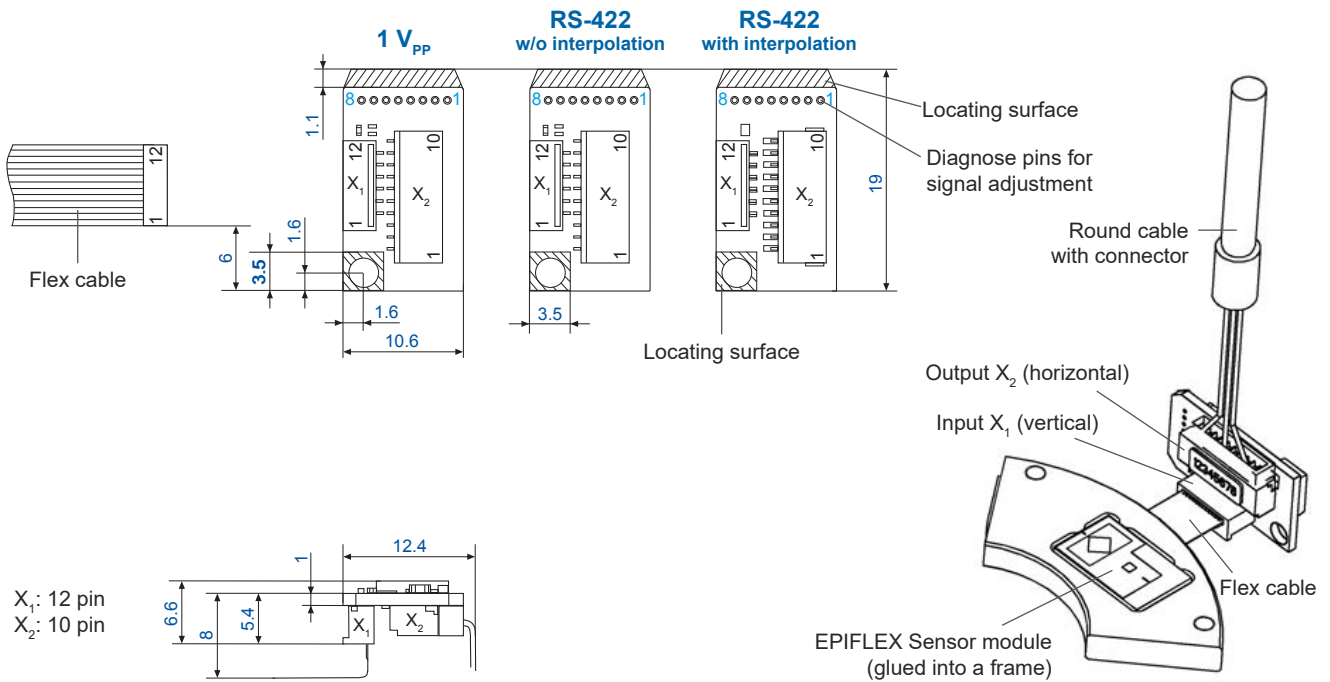

Image 10



## 6.10 Connector Variants

Type	Image connector	Pins
15-pin D-Sub		
9-pin D-Sub		
12-pin round connector M23 (Plastic-coated connector)		

Chart 6

## 6.11 PIN Assignment

### 15 pin D-Sub Connector

PIN	1	2	3	4	5	6	7	8	9	10	11	12	13	14	15	Housing
1 V <sub>PP</sub>	-	-	-	U <sub>0-</sub>	U <sub>2-</sub>	U <sub>1-</sub>	-	5V	0V	-	-	U <sub>0+</sub>	U <sub>2+</sub>	U <sub>1+</sub>	Inner shield	Outer shield
RS 422	-	-	NAS	Z <sub>0-</sub>	Z <sub>2-</sub>	Z <sub>1-</sub>	-	5V	0V	-	AS	Z <sub>0+</sub>	Z <sub>2+</sub>	Z <sub>1+</sub>	Inner shield*	Outer shield
Cable Ø 3.7 mm	-	-	vt	pk	rd	bn	-	bu	wh	-	ye	gy	bk	gn	-	-
Cable Ø 5.1 mm	-	-	vt	pk	rd	ye	-	bn	wh	-	bk	gy	bu	gn	wh/gy	-

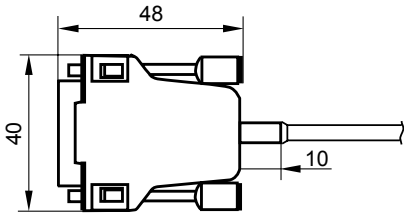
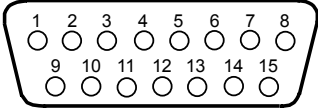
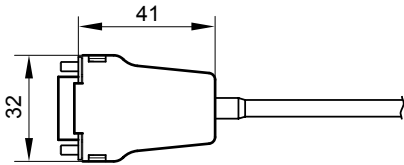
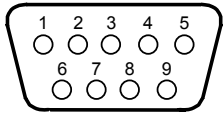
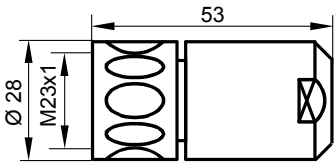
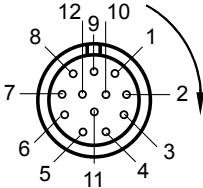
\* for signal processing in the 15-pin D-sub connector

### 9 pin D-Sub Connector

PIN	1	2	3	4	5	6	7	8	9	Housing
1 V <sub>PP</sub>	U <sub>1-</sub>	0V	U <sub>2-</sub>	Inner shield*	U <sub>0-</sub>	U <sub>1+</sub>	5V	U <sub>2+</sub>	U <sub>0+</sub>	Outer shield
RS 422	Z <sub>1-</sub>	0V	Z <sub>2-</sub>	NAS	Z <sub>0-</sub>	Z <sub>1+</sub>	5V	Z <sub>2+</sub>	Z <sub>0+</sub>	Outer shield
Cable Ø 3.7 mm	bn	wh	rd	vt	pk	gn	bu	bk	gy	-
Cable Ø 5.1 mm	ye	wh	rd	vt	pk	gn	bn	bu	gy	-

\* in the case of 1 V<sub>PP</sub> the violet wire remains unused, the inner shield (extended with wire color white/green) will be connected instead

### 12 pin Round Connector

PIN	1	2*	3	4	5	6	7	8	9	10*	11*	12*	Housing
1 V <sub>PP</sub>	U <sub>2-</sub>	5V	U <sub>0+</sub>	U <sub>0-</sub>	U <sub>1+</sub>	U <sub>1-</sub>	-	U <sub>2+</sub>	Inner shield	0V	0V	5V	Outer shield
RS 422	Z <sub>2-</sub>	5V	Z <sub>0+</sub>	Z <sub>0-</sub>	Z <sub>1+</sub>	Z <sub>1-</sub>	NAS	Z <sub>2+</sub>	-	0V	0V	5V	Outer shield
Cable Ø 3.7 mm	rd	bl	gy	pk	gn	bn	vt	bk	wh/gn	wh	wh	bu	-
Cable Ø 5.1 mm	rd	bn	gy	pk	gn	ye	vt	bu	-	wh	wh	br	-

\* PIN 2 and 12 bridged, PIN 10 and 11 bridged

#### 1 V<sub>PP</sub>

U<sub>1+</sub> Counting signal 0° (sin)  
 U<sub>1-</sub> Counting signal 180° (-sin)  
 U<sub>2+</sub> Counting signal 90° (cos)  
 U<sub>2-</sub> Counting signal 270° (-cos)  
 U<sub>0+</sub> Reference signal  
 U<sub>0-</sub> Neg. reference signal

0V Ground (GND)  
 5V Operating voltage (U<sub>B</sub>)  
 AS Error signal (monitoring signal)  
 NAS Neg. error signal

NAS high: Input signal within the tolerance range  
 NAS low: Input signal outside the tolerance range (check measuring system!)

#### RS 422

Z<sub>1+</sub> Counting signal 0°  
 Z<sub>1-</sub> Neg. counting signal 0° (180°)  
 Z<sub>2+</sub> Counting signal 90°  
 Z<sub>2-</sub> Neg. counting signal 90° (270°)  
 Z<sub>0+</sub> Reference signal  
 Z<sub>0-</sub> Neg. reference signal

SCL Programming wire clock  
 SDA Programming wire data

## 6.12 PIN Assignment for Connector PCB X<sub>1</sub>

PIN	1	2	3	4	5	6	7	8	9	10	11	12
1 V <sub>SS</sub>	SCL	SDA	GND	-	U <sub>1-</sub>	U <sub>1+</sub>	NAS	U <sub>0+</sub>	U <sub>0-</sub>	U <sub>2-</sub>	U <sub>2+</sub>	5V
RS 422	SCL	SDA	GND	-	Z <sub>1-</sub>	Z <sub>1+</sub>	NAS	Z <sub>0+</sub>	Z <sub>0-</sub>	Z <sub>2-</sub>	Z <sub>2+</sub>	5V

## 6.13 PIN Assignment for JST Miniature Connector X<sub>2</sub> and X<sub>3</sub>

### 10 pin JST Miniature Connector

PIN	1	2	3	4	5	6	7	8	9	10	
1 V <sub>PP</sub>	U <sub>2-</sub>	0V	-	U <sub>2+</sub>	U <sub>0-</sub>	-	U <sub>1-</sub>	U <sub>0+</sub>	U <sub>1+</sub>	5V	Inner shield
RS 422	Z <sub>2-</sub>	0V	NAS	Z <sub>2+</sub>	Z <sub>0-</sub>	AS	Z <sub>1-</sub>	Z <sub>0+</sub>	Z <sub>1+</sub>	5V	-
Cable Ø 3.7 mm	rd	wh	vt	bk	pk	ye	bn	gy	gn	bu	-
Cable Ø 5.1 mm	rd	wh	-	bu	pk	-	ye	gy	gn	bn	wh/gn

### 14 pin JST Miniature Connector

PIN	1	2	3	4	5	6	7	8	9	10	11	12	13	14	
1 V <sub>PP</sub>	0V	U <sub>1-</sub>	-	SCL	SDA	-	U <sub>1+</sub>	U <sub>0+</sub>	U <sub>2-</sub>	5V	U <sub>2+</sub>	U <sub>0-</sub>	S2	S1	Inner shield
RS 422	0V	Z <sub>1-</sub>	NAS	SCL	SDA	-	Z <sub>1+</sub>	Z <sub>0+</sub>	Z <sub>2-</sub>	5V	Z <sub>2+</sub>	Z <sub>0-</sub>	S2	S1	
Cable Ø 5.1 mm	wh	ye	vt	bk	bn/gn	-	gn	gy	rd	bn	bu	pk	wh/ye	ye/bn	wh/gn

#### 1 V<sub>PP</sub>

U<sub>1+</sub> Counting signal 0° (sin)  
 U<sub>1-</sub> Counting signal 180° (-sin)  
 U<sub>2+</sub> Counting signal 90° (cos)  
 U<sub>2-</sub> Counting signal 270° (-cos)  
 U<sub>0+</sub> Reference signal  
 U<sub>0-</sub> Neg. reference signal

0V Ground (GND)  
 5V Operating voltage (U<sub>B</sub>)  
 AS Error signal (monitoring signal)  
 NAS Neg. error signal

NAS high: Input signal within the tolerance range  
 NAS low: Input signal outside the tolerance range (check measuring system!)

#### RS 422

Z<sub>1+</sub> Counting signal 0°  
 Z<sub>1-</sub> Neg. counting signal 0° (180°)  
 Z<sub>2+</sub> Counting signal 90°  
 Z<sub>2-</sub> Neg. counting signal 90° (270°)  
 Z<sub>0+</sub> Reference signal  
 Z<sub>0-</sub> Neg. reference signal

SCL Programming wire clock  
 SDA Programming wire data

## 6.14 Electromagnetic Compatibility (EMC)



Please observe the following to ensure maximum protection against electrical and magnetic fields:

- The encoder must be mounted to a galvanic conductive surface. The mounting surfaces, the threads of the mounting screws and the threads in the machine must be free from electrically non-conductive coatings.
- Maintain the NUMERIK JENA shielding concept for the measuring system!
- Shielding for encoders without connectors:
  - When connected directly with the evaluation electronics, ensure that the external shield of the cable is well grounded
  - If cable connectors (e.g. terminal strips, etc.) are used, connect the external shields of the cables with each other and with the shielding of the cable connector
- When using additional electronics, connect the housing electrically conducting to ensure good galvanic conductivity. For insulated installation the housing should be connected at the shortest distance by an additional potential equalization line (Cu line with cross section  $\geq 6 \text{ mm}^2$ ) with the machine's protective ground.
- Please contact the NUMERIK JENA support or that of the appropriate manufacturer if you experience any problems when working with specific display or control units.

## 6.15 Shielding Concepts

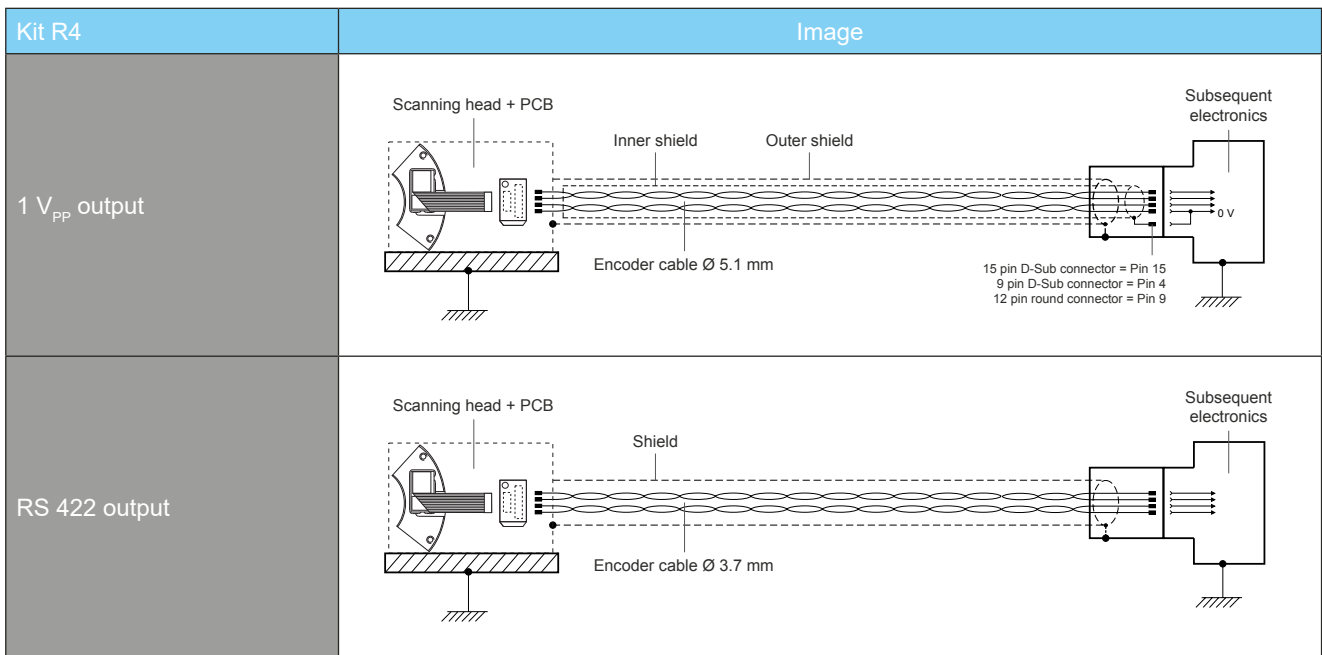

Chart 7

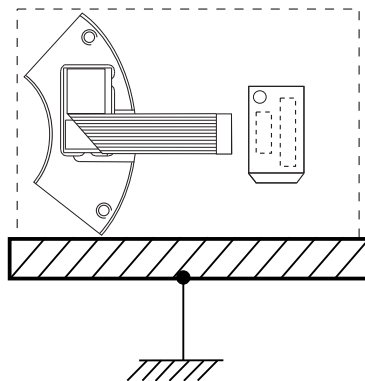

Image 13

**ATTENTION!** The user has to assure an EMC-compatible shielding of the scanning head and the PCB!

## 6.16 Voltage Output 1 V<sub>PP</sub>

### Optimal Connection Circuit

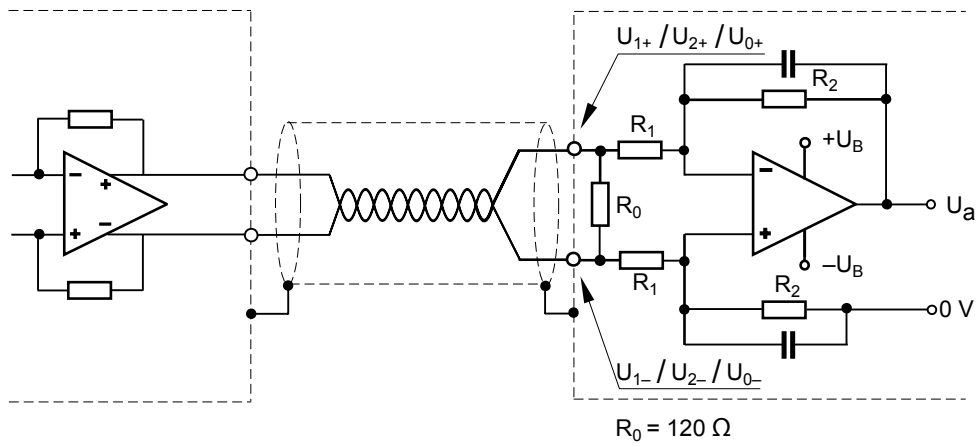

Image 14

### Signal Curve

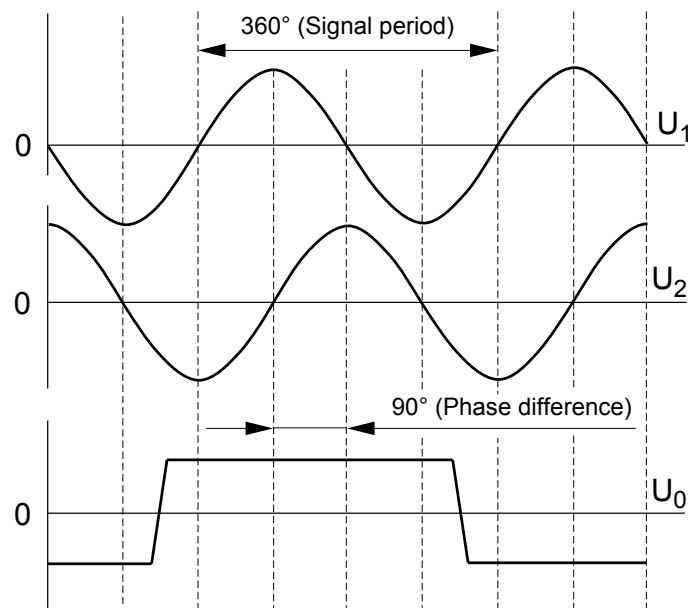

Image 15

Difference signals measured at  $R_0$ :

$$U_1 = U_{1+} - U_{1-} = 0.6 \dots 1.2 V_{PP} \quad (\text{Rated voltage: } 1 V_{PP})$$

$$U_2 = U_{2+} - U_{2-} = 0.6 \dots 1.2 V_{PP} \quad (\text{Rated voltage: } 1 V_{PP})$$

$$U_0 = U_{0+} - U_{0-} = 0.5 \dots 1.2 V \quad (\text{Rated voltage: } 0.8 V)$$

## 6.17 Square-Wave Output RS-422

### Optimal Connection Circuit

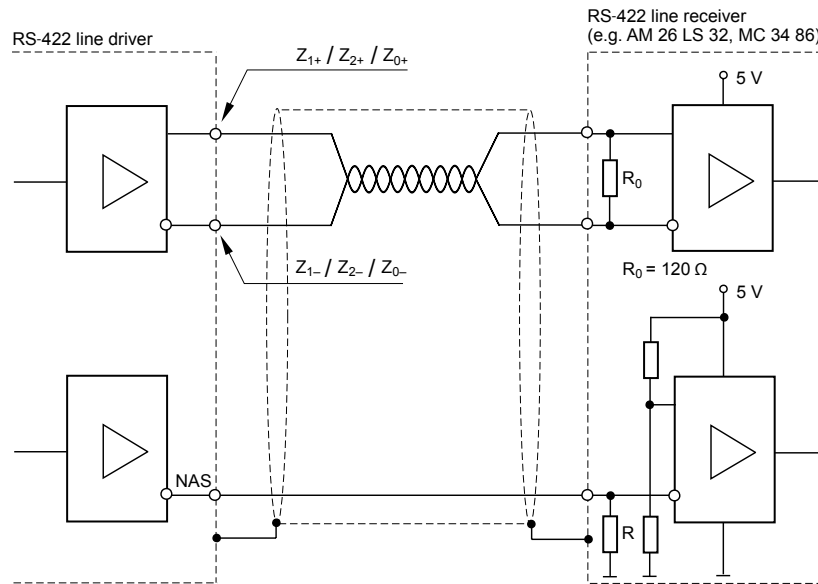

Image 16

### Signal Curve

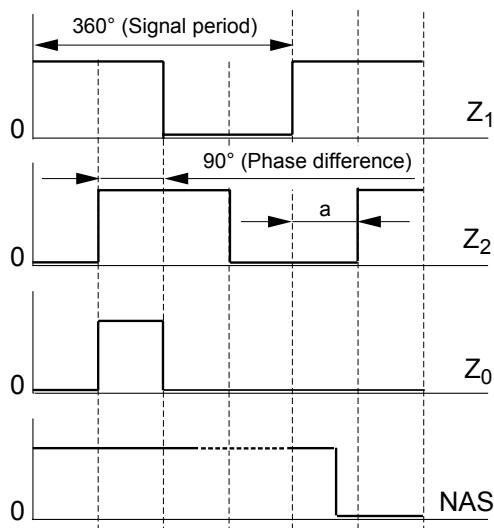

Image 17

#### NAS high:

Encoder functioning properly, input signals within tolerance range

#### NAS low:

Check the measuring system

#### a:

Minimum edge separation as a function of the interpolation factor and traversing speed

In order to avoid electromagnetic interference, the cable adaptation with a terminal resistor of  $R_0 = 120 \Omega$  is necessary. When connecting more than one parallel signal input to an encoder output signal (e.g. linear motors with parallel connection to position controller, speed controller or acceleration controller) ensure that the resulting terminal resistance of these inputs is  $R_{0res} \approx 120 \Omega$ .

## 6.18 Online Compensation (Offset and Amplitude Control)

Contamination and mounting errors lead to interferences in the optical scanning of the graduated disk by the scanning head and so to periodic deformations of the sinusoidal counting track signals, which are exemplified as

- Offset deviations
- Amplitude deviations
- Amplitude differences between the sine and cosine channels and lead to interpolation errors.

### Contaminated Graduated disk

Scanning head signal with contaminated graduated disk before activation of the online compensation.

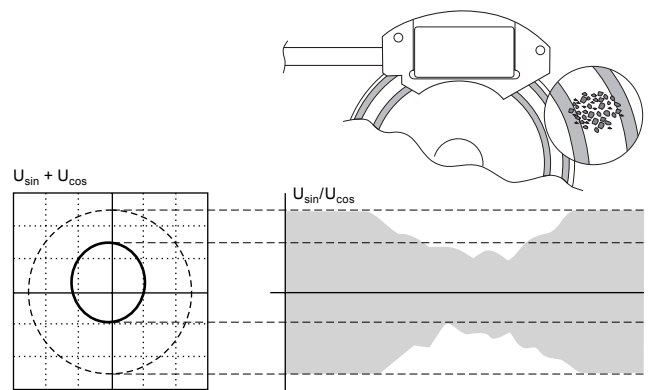

Image 18

### Incorrect Mounting

Scanning head signal with faulty mounting before activation of the online compensation.

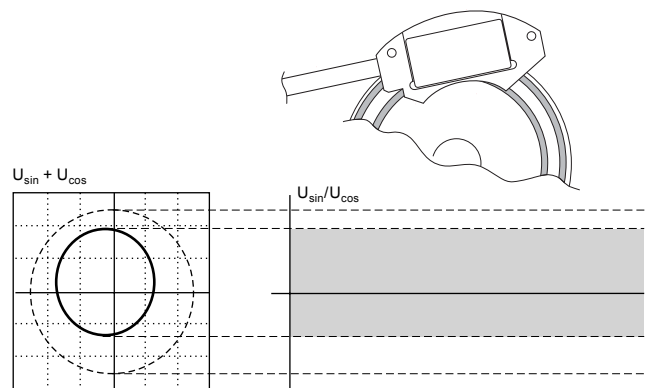

Image 19

### Active Online Compensation

Scanning head signal with contaminated graduated disk and/or faulty mounting after activation of the online compensation.

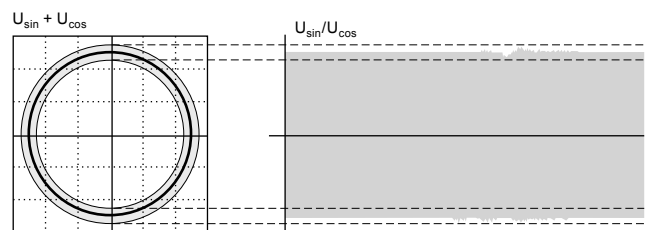

Image 20

Through the online compensation the signals generated by the measuring module are automatically corrected within the sensor without following error over the entire velocity range.

This measure not only increases the accuracy, but also the reliability of the encoder.

## 7. General Mounting Instructions

### 7.1 Delivery Contents

#### Standard

- Kit R4 scanning head (according to the ordered specification)
- Connector PCB (according to the ordered specification)
- Connector incl. cable
- Graduated disk (according to the ordered specification)
- Information sheet

#### Optional

- ADJUSTMENT TOOL
- Extension cable

### 7.2 Encoder Mounting Position



- The mounting position of the encoder system is arbitrary.
- The operator of the encoder system is responsible for appropriate design measures to protect the scanning head and graduated disk from contamination.
- In any installation position the graduated disk and scanning window of the scanning head should be easily accessible for cleaning. Prevent contamination and foreign elements from having an influence on the operation!
- The counting direction of the encoder is positive (increasing measuring values) if the scanning head is positioned to the graduated disk like shown in the image below.

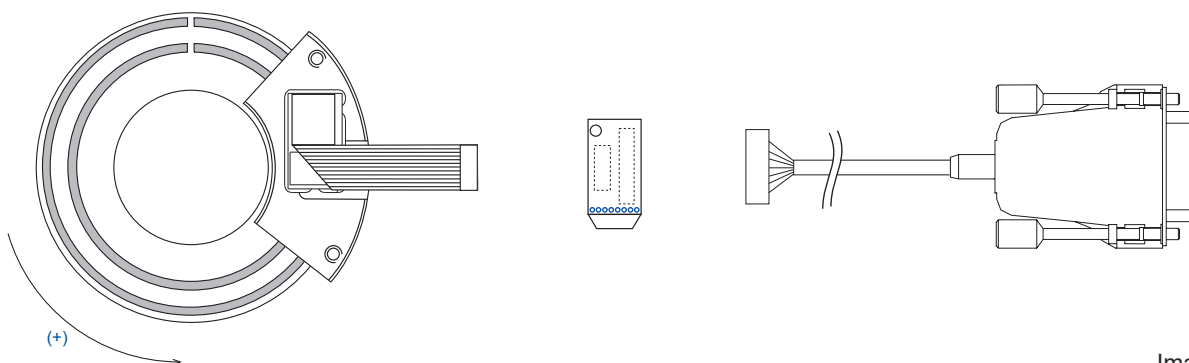

Image 21

## 7.3 Mounting of the Encoder System

### 7.3.1 Scanning Head with Frame

The following shows the assembly of a Kit R4 encoder system. Scanning head and graduated disk must be positioned to each other like shown in the image.

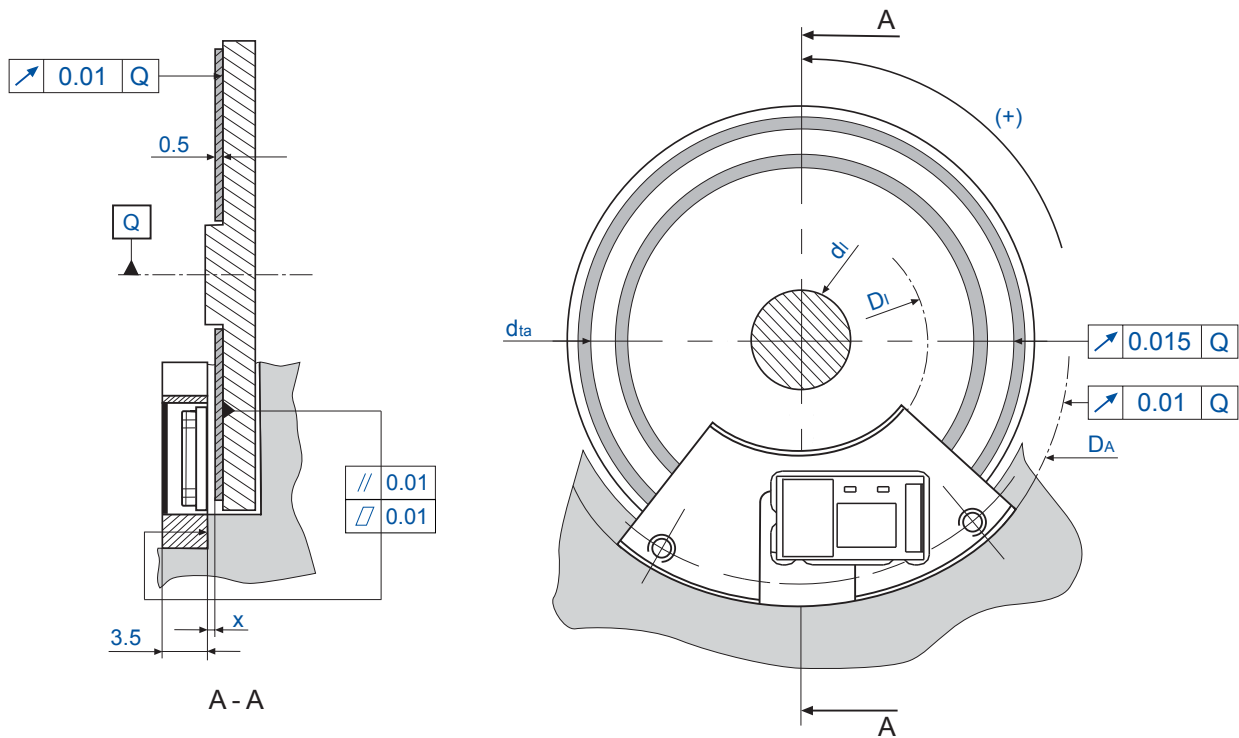

Image 22

- $D_A$  Outside diameter of the stop surface (for scanning head)
- $D_i$  Inside diameter of the stop surface (for scanning head)
- $d_i$  Diameter of the axis
- $d_{ta}$  Outer diameter of the incremental track
- $x$  Working distance (air gap)

#### Notes on Assembling

The graduated disk must be adjusted regarding the rotational axis Q thus the center diameter of the incremental track  $d_{ta}$  observe the eccentricity R.

### 7.3.2 Dimensions and Mounting Tolerances - with Frame

Type	$D_A$ [mm]	$D_I$ [mm]	$d_i$ [mm]	R [mm]	x
RS 13/5.5/2048	-	-	-	0.015	$0.5 \pm 0.03$
RS 13/6/2048	-	-	-		$0.5 \pm 0.03$
RS 19/6/3600	$38^{H6}$	-	-	0.015	$0.5 \pm 0.02$
RS 19/9/3600	$38^{H6}$	-	-		$0.5 \pm 0.02$
RS 29/16/900	$45^{H6}$	$16_{h6}$	-	0.015	$0.6 \pm 0.1$
RS 29/16/1000	$45^{H6}$	$16_{h6}$	-		$0.7 \pm 0.05$
RS 29/16/4500	$45^{H6}$	$16_{h6}$	-		$0.6 \pm 0.05$
RS 29/20/900	$45^{H6}$	$16_{h6}$	-		$0.6 \pm 0.1$
RS 39/9.97/3600	$55^{H6}$	$26_{h6}$	-	0.015	$0.4 \pm 0.05$
RS 39/25/1800	$55^{H6}$	$26_{h6}$	-		$0.5 \pm 0.1$
RS 39/25/2048	$55^{H6}$	$26_{h6}$	-		$0.7 \pm 0.1$
RS 39/25/3600	$55^{H6}$	$26_{h6}$	-		$0.4 \pm 0.05$
RS 39/25/6000	$55^{H6}$	$26_{h6}$	-		$0.6 \pm 0.05$
RS 39/30/3600	$55^{H6}$	$26_{h6}$	-		$0.4 \pm 0.05$
RS 45/30/9000	$64^{H6}$	$34_{h6}$	-	0.015	$0.4 \pm 0.02$
RS 64/48.5/2048	$82^{H6}$	$50.8_{h6}$	-	0.015	$0.8 \pm 0.05$
RS 64/48.5/4096	$82^{H6}$	$50.8_{h6}$	-		$0.6 \pm 0.05$
RS 64/48.5/9000	$82^{H6}$	$50.8_{h6}$	-		$0.9 \pm 0.05$
RS 64/48.5/10000	$82^{H6}$	$50.8_{h6}$	-		$0.7 \pm 0.05$
RS 92/70/3600	$110^{H6}$	$78_{h6}$	-	0.015	$0.5 \pm 0.1$
RS 92/70/9000	$110^{H6}$	$78_{h6}$	-		$0.4 \pm 0.05$
RS 92/70/18000	$110^{H6}$	$78_{h6}$	-		$0.4 \pm 0.05$
RS 92/76/3600	$110^{H6}$	$78_{h6}$	-		$0.5 \pm 0.1$
RS 92/80/3600	$110^{H6}$	$78_{h6}$	-		$0.5 \pm 0.1$
RS 142/120/5400	$160^{H6}$	$126_{h6}$	-	0.015	$0.8 \pm 0.05$
RS 142/120/18000	$160^{H6}$	$126_{h6}$	-		$1.2 \pm 0.05$
RS 142/122/5400	$160^{H6}$	$126_{h6}$	-		$0.8 \pm 0.05$
RS 142/128/18000	$160^{H6}$	$126_{h6}$	-		$1.2 \pm 0.05$
RS 192/160/24000	$210^{H6}$	$180_{h6}$	-	0.015	$1.1 \pm 0.05$

(regarding to image 22)

Chart 8

- $D_A$  Outside diameter of the stop surface (for scanning head)
- $D_I$  Inside diameter of the stop surface (for scanning head)
- $d_i$  Diameter of the axis
- R Radial eccentricity - outer diameter of the incremental track
- x Working distance (air gap)



### 7.3.4 Dimensions and Mounting Tolerances - without Frame

Typ	L	d <sub>i</sub> [mm]	R [mm]	x
RS 13/5.5/2048	10.5 ±0.01	-	0.015	0.5 ±0.03
RS 13/6/2048	10.5 ±0.01	-		0.5 ±0.03
RS 19/6/3600	13.5 ±0.01	-	0.015	0.5 ±0.02
RS 19/9/3600	13.5 ±0.01	-		0.5 ±0.02
RS 29/16/900	18.5 ±0.01	-	0.015	0.6 ±0.1
RS 29/16/1000	18.5 ±0.01	-		0.7 ±0.05
RS 29/16/4500	18.5 ±0.01	-		0.6 ±0.05
RS 29/20/900	18.5 ±0.01	-		0.6 ±0.1
RS 39/9.97/3600	23.5 ±0.02	-	0.015	0.4 ±0.05
RS 39/25/1800	23.5 ±0.02	-		0.5 ±0.1
RS 39/25/2048	23.5 ±0.02	-		0.7 ±0.1
RS 39/25/3600	23.5 ±0.02	-		0.4 ±0.05
RS 39/25/6000	23.5 ±0.02	-		0.6 ±0.05
RS 39/30/3600	23.5 ±0.02	-		0.4 ±0.05
RS 45/30/9000	26.5 ±0.02	-	0.015	0.4 ±0.02
RS 64/48.5/2048	36.0 ±0.02	-	0.015	0.8 ±0.05
RS 64/48.5/4096	36.0 ±0.02	-		0.6 ±0.05
RS 64/48.5/9000	36.0 ±0.02	-		0.9 ±0.05
RS 64/48.5/10000	36.0 ±0.02	-		0.7 ±0.05
RS 92/70/3600	50.0 ±0.02	-	0.015	0.5 ±0.1
RS 92/70/9000	50.0 ±0.02	-		0.4 ±0.05
RS 92/70/18000	50.0 ±0.02	-		0.4 ±0.05
RS 92/76/3600	50.0 ±0.02	-		0.5 ±0.1
RS 92/80/3600	50.0 ±0.02	-		0.5 ±0.1
RS 142/120/5400	75.0 ±0.02	-	0.015	0.8 ±0.05
RS 142/120/18000	75.0 ±0.02	-		1.2 ±0.05
RS 142/122/5400	75.0 ±0.02	-		0.8 ±0.05
RS 142/128/18000	75.0 ±0.02	-		1.2 ±0.05
RS 192/160/24000	100.0 ±0.05	-	0.015	1.1 ±0.05

(regarding to image 23)

Chart 9

- L Distance from contact surface of the sensor module to the center of the rotational axis
- d<sub>i</sub> Diameter of the axis
- R Radial eccentricity - outer diameter of the incremental track
- x Working distance (air gap)

## 7.4 Mounting of the Graduated Disk

To prevent deformation of the graduated disk by external forces it is recommended to glue the disk to a hub (see image 24). Additionally the mounting and mechanical adjustment to a shaft will be simplified.

The use of a rotary table for mounting will be recommended. For optical vernier adjustment of the graduated disk an adjustment microscope with line marking in the intermediate image plane should be used.

### Recommended Mounting Steps:

- 1 If necessary, clean all mounting surfaces before mounting by following the instructions in chapter 9 "Cleaning".
- 2 Center and fix the hub to the rotary table.
- 3 Apply an evenly spreaded adhesive layer to the bottom of the graduated disk. The use of a two-component adhesive, e.g. "Epicol 230004" or an adhesive with similar properties is recommended. Use an appropriate tool, e.g. a dispenser.
- 4 Place the graduated disk on the hub carefully and center it primarily according to the outer diameter of the disk.
- 5 Focus the edge of the graduated disk by using the adjustment microscope. Rotate the graduated disk and determine the location of the minimum deviation **a** and the maximum deviation **b** of the concentricity (see image 17).
- 6 Focus the location of the minimum deviation **a** again and move the graduated disk carefully by half the amount of the difference between deviation **a** and deviation **b**. By doing so the centre of the incremental track and the pivot of the shaft will be aligned.
- 7 Weight down the graduated disk by using an appropriate loading (see image 18) and let the adhesive cure for approximately 1 hour. Please prevent any damage or scratching of the graduated disk by using an appropriate padding between disk and loading.
- 8 Focus the outer diameter of the incremental track of the graduated disk for vernier adjustment. Rotate the disk and determine the location of the minimum deviation **a** and the maximum deviation **b** again.
- 9 Repeat as well as described in step 6. Examine the concentricity and repeat step 6 as often as necessary to reach the required concentricity deviation. Let the adhesive cure (e.g. "Epicol 230004", curing time = 24 hours at room temperature).
- 10 Finally fix and center the hub to the shaft.

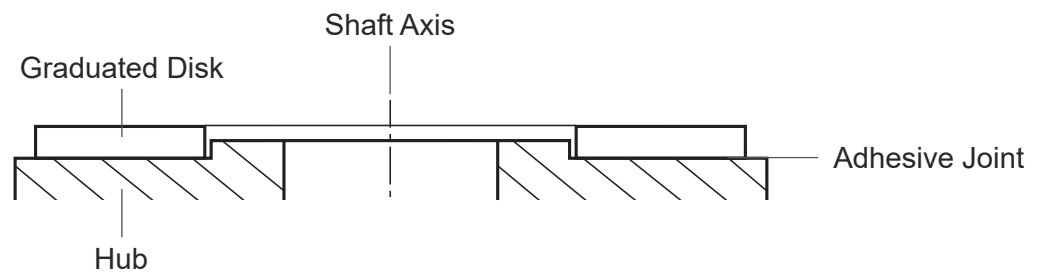

Image 24

### Centering of the Graduated Disk with an Adjustment Microscope

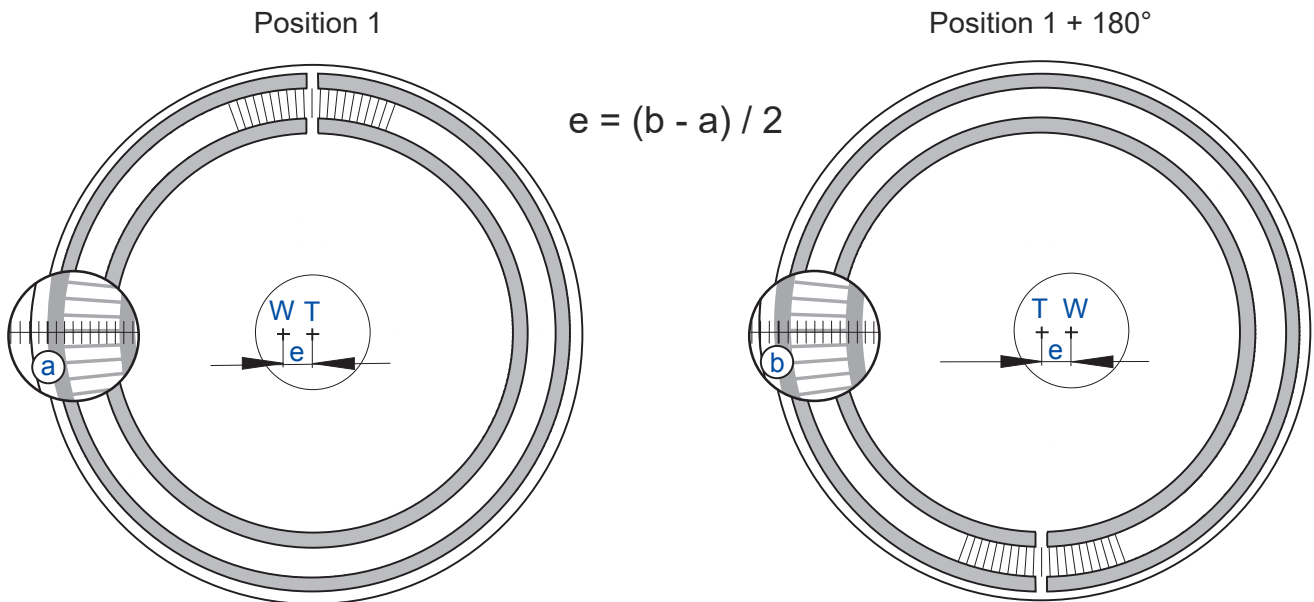

Image 25

- W Center of the axis
- T Center of the incremental track
- e Centering error
- a Minimum deviation
- b Maximum deviation

## Mounting Example with Loading After Glueing the Graduated Disk

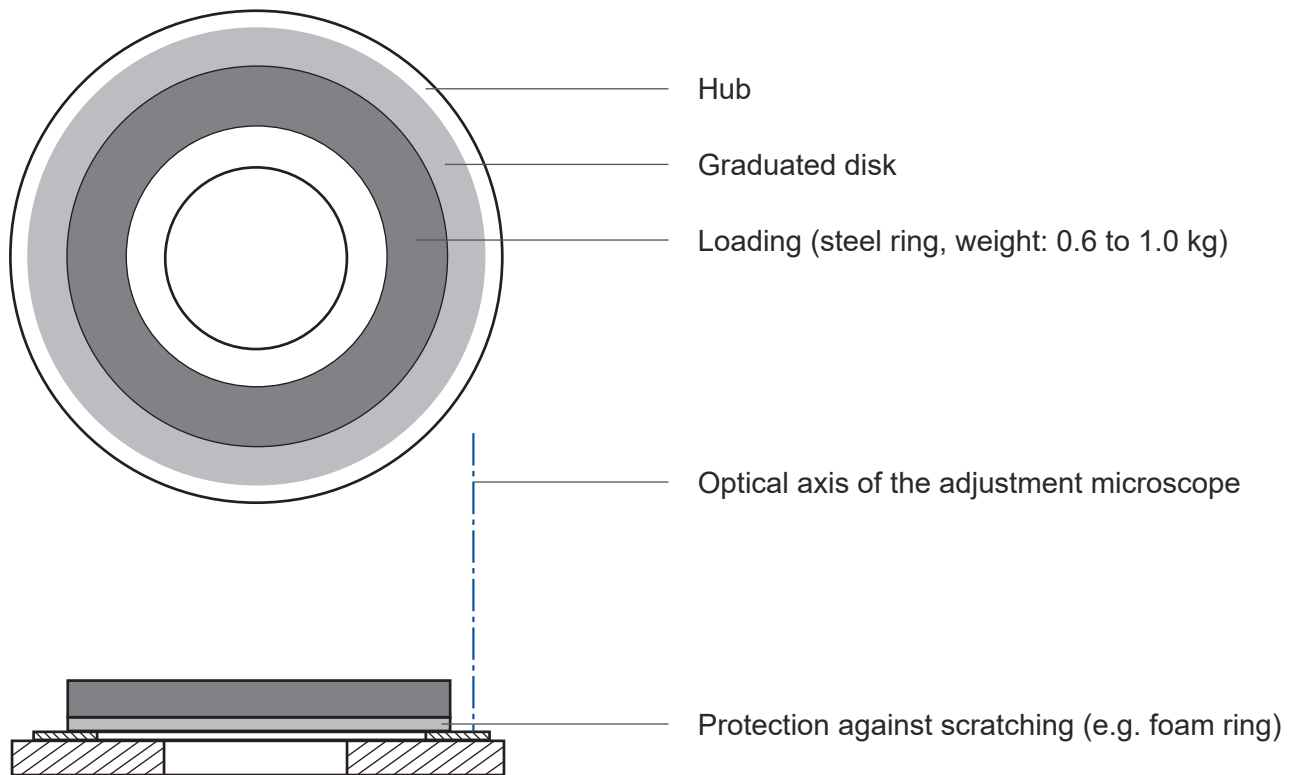

Image 26

### Mounting Instructions

- Remove any residue of adhesive which appeared during the mounting procedure from hub and graduated disk immediately.
- Clean the surfaces by following the instructions in chapter 9 "Cleaning".
- Please prevent any damage or scratching of the graduated disk while removing the loading. The surface of the graduated disk is very scratch-sensitive.
- Please pay attention to the data sheets and notes of the adhesive manufacturer!

## Notes

NUMERIK JENA offers the mechanical mounting as well as the adjustment of the graduated disk to a customized hub as a service. The manufacturing of the customized hub can be done by NUMERIK JENA also.

The hub must be designed principally as prescribed in the following image.

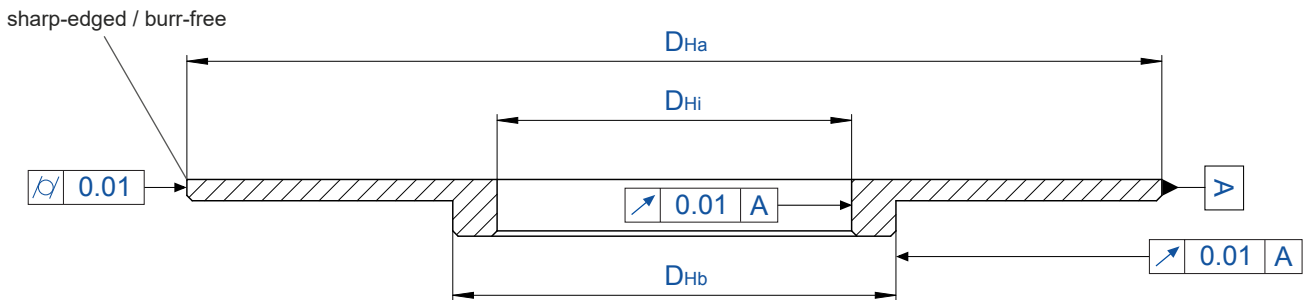

Image 27

- $D_{Ha}$  Outside diameter of the hub
- $D_{Hi}$  Inside diameter of the hub
- $D_{Hb}$  Adjustment diameter of the hub

The inside as well as the outside diameter must be designed as prescribed in the following:

- $D_{Ha} \geq$  Outside diameter of the graduated disk + 1.0 mm
- $D_{Hi} \leq$  Inside diameter of the graduated disk - 1.0 mm

The inside diameter  $D_{Hi}$  as well as the adjustment diameter  $D_{Hb}$  can be used for the mechanical adjustment on a rotary table. For mounting at NUMERIK JENA the diameter must not exceed or exceed the following values:

- $D_{Hi}$  26 ... 135 mm
- $D_{Hb}$  30 ... 140 mm

---

## 7.5 Mounting of the Scanning Head

- If necessary, clean all mounting surfaces of the scanning head and machine element before mounting by following the instructions in chapter 9 “Cleaning”.
- Remove the protection foil from the scanning window of the scanning head.
- Please pay attention to the indicated mechanical mounting tolerances (see page 29 et seq.).
- Position the encoder cable including a strain relief near the scanning head (see also point 6.7).
- Connect the encoder cable to the evaluation electronics and pay attention to the pin assignment.  
**The evaluation electronics must be switched off!**
- After connecting the encoder cable switch the evaluation electronics on and test the functionality.
- If there are errors in the function or during measurement, please read chapter 10 “Troubleshooting” first. If these information are not helpful for your problem, please contact the technical support of NUMERIK JENA or an authorized subsidiary in your country.

## 8. Signal Adjustment with ADJUSTMENT TOOL

Before delivery the encoders from NUMERIK JENA will be tested and electronically adjusted under ideal mounting conditions. Furthermore, the sensor modules offer the possibility of an electronic signal adjustment after the mounting into the application. This allows the user optimize the encoder signals regarding to the mechanical mounting conditions (tolerances).

The ADJUSTMENT TOOL and the related EPIFLEX software was designed to simplify and make the signal adjustment more effective.

### 8.1 Functions of the ADJUSTMENT TOOL

- Representation of the sinusoidal counting signals with amplitude, offset and phase position
- Representation of the position and width of the index signal
- Evaluation of the mechanical mounting conditions
- Automatic signal adjustment and programming of the sensor module
- Electronic readjustment of the amplitude and offset of the sensor signals
- Adjustment of the position and width of the index signal

### 8.2 Dynamic Offset and Amplitude Control (Online Compensation)

The encoders of NUMERIK JENA are equipped with a dynamic amplitude and offset control (online compensation). The analog diode signals will be corrected to their nominal values in real time. This reduces measuring errors caused by contamination as well as from inaccuracies. The phase position between the sine and cosine signals and the position of the index signal are not influenced by the online compensation.

With help of the EPIFLEX Software the preadjusted nominal values of the online compensation can be influenced.

### 8.3 Scope of Delivery

- ADJUSTMENT TOOL black box
- Diagnostic cable to connect the measuring system
- USB cable to connect a PC
- USB - D-SUB - adapter cable (15-pin)
- Exchangeable 8-pin plug connectors



Image 28

## 8.4 EPIFLEX Software

The EPIFLEX software was especially designed for the ADJUSTMENT TOOL. It offers the user versatile possibilities to bring the encoder into service. It also allows the user to display the sensor signals and evaluate them without using an oscilloscope or other expensive hardware. Furthermore it is possible to program respectively optimize the encoder to the existing mounting conditions automatically.

**The EPIFLEX software is available for free via download on the NUMERIK JENA website under [www.numerikjena.com](http://www.numerikjena.com).**

The EPIFLEX software is suitable for the following operating systems:

- Windows 7, 8, 10 (32 or 64 bit)

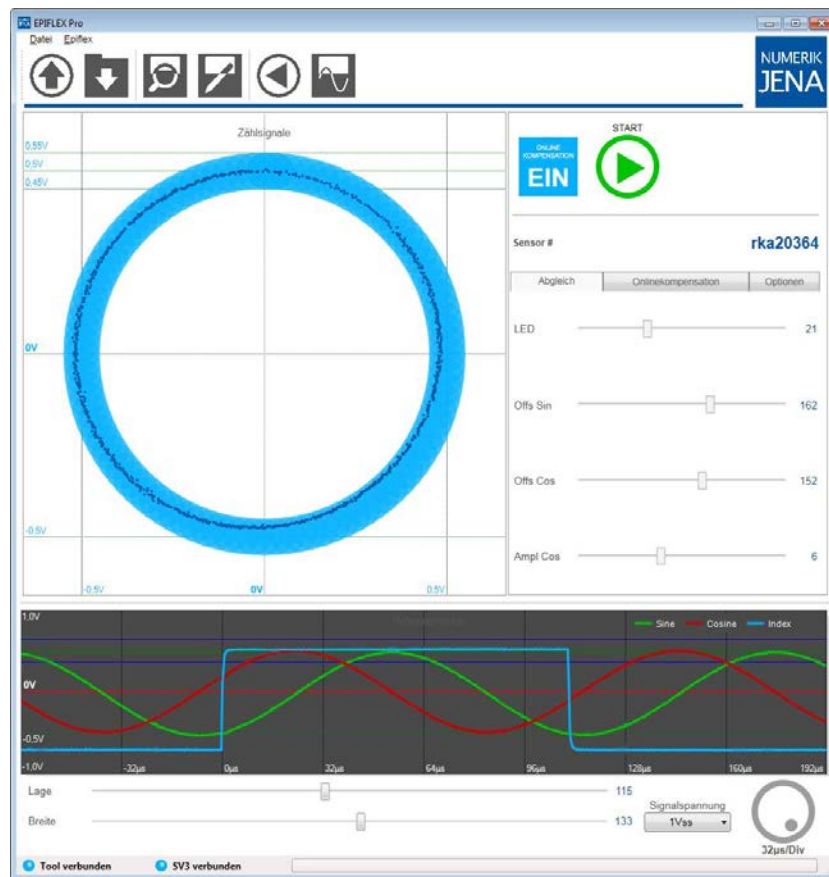

Image 29

Further information about the ADJUSTMENT TOOL and the EPIFLEX software can be found on the NUMERIK JENA website.

## 9. Cleaning

- The measuring systems from NUMERIK JENA are delivered in a pre-cleaned condition. Re-cleaning of the surfaces is only recommended if they have been contaminated during installation of the components.
- During operation of the measuring system in a plant, occasional cleaning of the sensor surface of the scanning head (scanning window for counting and reference track) or the graduated disk may be necessary, depending on the installation position and the ambient conditions.
- When using the monitoring signal output by the sensor head, the need for cleaning may be indicated.
- When cleaning the components, make sure that deposited particles do not scratch the scanning window of the scanning head or the surface of the graduated disk! The surfaces of the scanning window and the graduated disk are sensitive to scratches and should only be cleaned with extreme care.
- Clean with absorbent cotton or a soft, lint-free cloth using a solvent. Cleaning without a solvent increases the risk of damaging the surfaces. Only isopropanol or acetone is recommended as a solvent. The use of other solvents may damage the surfaces.
- When cleaning the disks surface, adhere to the wiping direction specified in image 24. Wiping across the applied increments increases the risk of damage and can lead to failure of the measuring system.
- Avoid contact between solvents and the adhesive layer! This can cause the adhesive layer to dissolve and thus reduce the adhesive strength or cause the graduated disk to detach completely.
- ATTENTION: Isopropanol and acetone are flammable liquids!

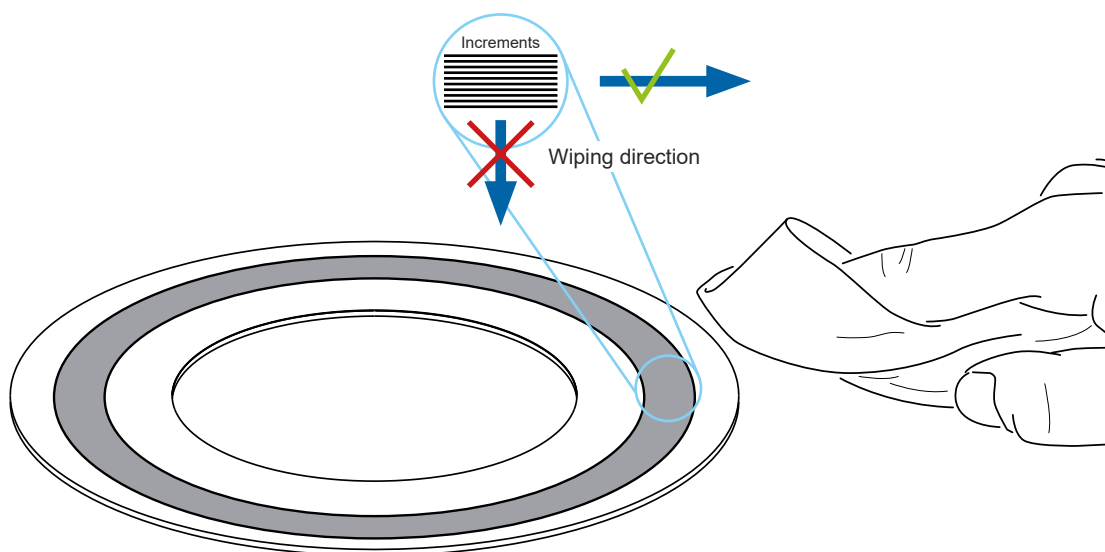

Image 30

## 10. Troubleshooting

The functions of all scanning heads and accuracy of all scale tapes are tested before the encoders are shipped. However, if troubles or problems should occur, please read the following points in the chart and proceed according these information.

If this is not helpful, please contact the technical support of NUMERIK JENA GmbH or one of our authorized subsidiaries. You will find respective contact data on the NUMERIK JENA webside [www.numerikjena.com](http://www.numerikjena.com).

Error	Possible causes	Solution
No measuring signal	No power at the scanning head	<ul style="list-style-type: none"> <li>• Check the status of the evaluation electronics</li> <li>• Check the connection assignment between the encoder and the evaluation electronics</li> </ul>
Error message from the evaluation electronics	Following error due to temporary failure of the measuring signal	<ul style="list-style-type: none"> <li>• Check the assignment of the graduated disk to the scanning head</li> <li>• p.r.n. readjust mechanically</li> <li>• Readjust electronically with ADJUSTMENT TOOL*</li> </ul>
Rough, loud motor running	Irregular edge separations of the counting signals due to interpolation errors	
Counting error (compared to a standard)	Mounting error	
No reference signal	Mounting error (results in faulty gating of the reference signal and counting signal)	
Reference mark can only be detected from one direction		
Reference mark appears twice		
Not all reference marks are detected		
Failure signal reports (for RS 422)	Mounting error (results in level of the analog signal from the sensor being too low)	Clean the graduated disk (see also chapter 9 „Cleaning“)
	Contamination on the graduated disk (results in level of the analog signal from the sensor being too low)	
	Encoder function operating error	Contact the technical support of NUMERIK JENA

Chart 10

\* see also chapter 8

## 11. Ordering Key

### 11.1 Scanning Head

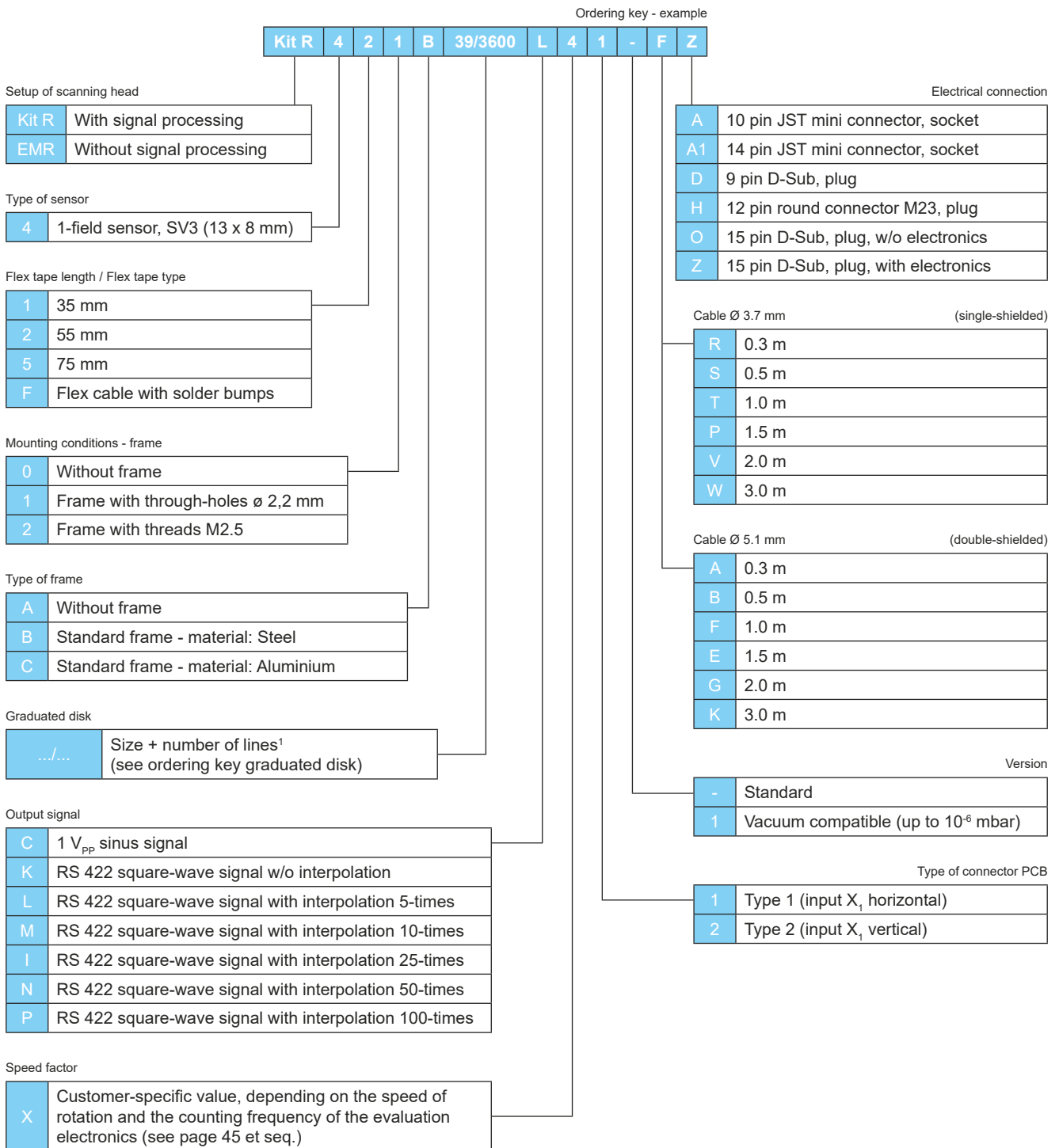

<sup>1</sup> The chosen combination of size + number of lines in the ordering key scanning head must be identical to the chosen graduated disk.

#### NOTE

Deviations from the standard configurations listed here are possible in principle. We would be happy to work with you to develop your individual solution. Simply get in touch with your local contact person. You will find a corresponding contact list on our website under "Contact".

## 11.2 Speed Chart for RIK Series

### 11.2.1 Kit R4 with Op-Amp

The maximum attainable speed of rotation of the encoder is determined by the maximum output frequency of the interpolator and/or the maximum counting frequency of the operator's evaluation electronics (e.g. controller or display).

Please take the suitable values for your application from the following charts and enter it into the corresponding place (for "X") in the ordering key. Pay attention to your chosen interpolation factor and the number of lines of the graduated disk first. If you have found the respective information, please check if your evaluation electronics is able to achieve the needed counting frequency and the maximum speed of rotation. The maximum speed of rotation should not be exceeded.

The maximum scanning frequency of the encoder amounts to 200 kHz standardly, hence the maximum attainable speed of rotation will be derived from that. The op-amp decouples parasitic frequencies and improves the interference immunity of the encoder under unfavorable conditions. The encoders from NUMERIK JENA are available without op-amp also. Thus it is possible to increase the scanning frequency which consequently enables higher speed of rotation.

#### C Without interpolation factor

Value for X	Number of lines (Z)														Min. counting frequency of the evaluation electronics (in MHz)	
	900	1,000	1,800	2,048	3,600	4,096	4,500	5,400	6,000	9,000	10,000	18,000	24,000	32,000	w/o 4-edge evaluation	with 4-edge evaluation
0	13,333	12,000	6,667	5,859	3,333	2,930	2,667	2,222	2,000	1,333	1,200	667	500	375	0.25	1

#### L Interpolation factor = 5

Value for X	Number of lines (Z)														Min. counting frequency of the evaluation electronics (in MHz)	
	900	1,000	1,800	2,048	3,600	4,096	4,500	5,400	6,000	9,000	10,000	18,000	24,000	32,000	w/o 4-edge evaluation	with 4-edge evaluation
1	2,222	2,000	1,111	977	556	488	444	370	333	222	200	111	83	63	0.25	1
2	4,444	4,000	2,222	1,953	1,111	977	889	741	667	444	400	222	167	125	0.50	2
Y	6,667	6,000	3,333	2,930	1,667	1,465	1,333	1,111	1,000	667	600	333	250	188	0.75	3
3	8,889	8,000	4,444	3,906	2,222	1,953	1,778	1,481	1,333	889	800	444	333	250	1.00	4
Z	13,333	12,000	6,667	5,859	3,333	2,930	2,667	2,222	2,000	1,333	1,200	667	500	375	1.50	6

#### M Interpolation factor = 10

Value for X	Number of lines (Z)														Min. counting frequency of the evaluation electronics (in MHz)	
	900	1,000	1,800	2,048	3,600	4,096	4,500	5,400	6,000	9,000	10,000	18,000	24,000	32,000	w/o 4-edge evaluation	with 4-edge evaluation
1	1,111	1,000	556	448	278	244	222	185	167	111	100	56	42	31	0.25	1
2	2,222	2,000	1,111	977	556	488	444	370	333	222	200	111	83	63	0.50	2
Y	3,333	3,000	1,667	1,465	833	732	667	556	500	333	300	167	125	94	0.75	3
3	4,444	4,000	2,222	1,953	1,111	977	889	741	667	444	400	222	167	125	1.00	4
Z	6,667	6,000	3,333	2,930	1,667	1,465	1,333	1,111	1,000	667	600	333	250	188	1.50	6
4	8,889	8,000	4,444	3,906	2,222	1,953	1,778	1,481	1,333	889	800	444	333	250	2.00	8
5	13,333	12,000	6,667	5,859	3,333	2,930	2,667	2,222	2,000	1,333	1,200	667	500	375	3.00	12

**I Interpolation factor = 25**

Value for X	Number of lines (Z)														Min. counting frequency of the evaluation electronics (in MHz)	
	900	1,000	1,800	2,048	3,600	4,096	4,500	5,400	6,000	9,000	10,000	18,000	24,000	32,000	w/o 4-edge evaluation	with 4-edge evaluation
	[rpm]															
1	444	400	222	195	111	98	89	74	67	44	40	22	17	13	0.25	1
2	889	800	444	391	222	195	178	148	133	89	80	44	33	25	0.50	2
Y	1,333	1,200	667	586	333	293	267	222	200	133	120	67	50	38	0.75	3
3	1,778	1,600	889	781	444	391	356	296	267	178	160	89	67	50	1.00	4
Z	2,667	2,400	1,333	1,172	667	586	533	444	400	267	240	133	100	75	1.50	6
4	3,556	3,200	1,778	1,563	889	781	711	593	533	356	320	178	133	100	2.00	8
5	5,333	4,800	2,667	2,344	1,333	1,172	1,067	889	800	533	480	267	200	150	3.00	12
6	7,111	6,400	3,556	3,125	1,778	1,563	1,422	1,185	1,067	711	640	356	267	200	4.00	16
7	8,889	8,000	4,444	3,906	2,222	1,953	1,778	1,481	1,333	889	800	444	333	250	5.00	20
8	10,667	9,600	5,333	4,688	2,677	2,344	2,133	1,778	1,600	1,067	960	533	400	300	6.00	24

**N Interpolation factor = 50**

Value for X	Number of lines (Z)														Min. counting frequency of the evaluation electronics (in MHz)	
	900	1,000	1,800	2,048	3,600	4,096	4,500	5,400	6,000	9,000	10,000	18,000	24,000	32,000	w/o 4-edge evaluation	with 4-edge evaluation
	[rpm]															
1	222	200	111	98	56	49	44	37	33	22	20	11	8	6	0.25	1
2	444	400	222	195	111	98	89	74	67	44	40	22	17	13	0.50	2
Y	667	600	333	293	167	146	133	111	100	67	60	33	25	19	0.75	3
3	889	800	444	391	222	195	178	148	133	89	80	44	33	25	1.00	4
Z	1,333	1,200	667	586	333	293	267	222	200	133	120	67	50	38	1.50	6
4	1,778	1,600	889	781	444	391	356	296	267	178	160	89	67	50	2.00	8
5	2,667	2,400	1,333	1,172	667	586	533	444	400	267	240	133	100	75	3.00	12
6	3,556	3,200	1,778	1,563	889	781	711	593	533	356	320	178	133	100	4.00	16
7	4,444	4,000	2,222	1,953	1,111	977	889	741	667	444	400	222	167	125	5.00	20
8	5,333	4,800	2,677	2,344	1,333	1,172	1,067	889	800	533	480	267	200	150	6.00	24

**P Interpolation factor = 100**

Value for X	Number of lines (Z)														Min. counting frequency of the evaluation electronics (in MHz)	
	900	1,000	1,800	2,048	3,600	4,096	4,500	5,400	6,000	9,000	10,000	18,000	24,000	32,000	w/o 4-edge evaluation	with 4-edge evaluation
	[rpm]															
1	111	100	56	49	28	24	22	19	17	11	10	6	4	3	0.25	1
2	222	200	111	98	56	49	44	37	33	22	20	11	8	6	0.50	2
Y	333	300	167	146	83	73	67	56	50	33	30	17	13	9	0.75	3
3	444	400	222	195	111	98	89	74	67	44	40	22	17	13	1.00	4
Z	667	600	333	293	167	146	133	111	100	67	60	33	25	19	1.50	6
4	889	800	444	391	222	195	178	148	133	89	80	44	33	25	2.00	8
5	1,333	1,200	667	586	333	293	267	222	200	133	120	67	50	38	3.00	12
6	1,778	1,600	889	781	444	391	356	296	267	178	160	89	67	50	4.00	16
7	2,222	2,000	1,111	977	556	488	444	370	333	222	200	111	83	63	5.00	20
8	2,677	2,400	1,333	1,172	667	586	533	444	400	267	240	133	100	75	6.00	24

## 11.2.2 Kit R4 without Op-Amp

The maximum scanning frequency of the encoder without op-amp amounts to 500 kHz, hence the maximum attainable traversing speed will be derived from that.

### C (1 VSS) or K (RS 422) Without interpolation factor

Value for X	Number of lines (Z)														Min. counting frequency of the evaluation electronics (in MHz)	
	900	1,000	1,800	2,048	3,600	4,096	4,500	5,400	6,000	9,000	10,000	18,000	24,000	32,000	w/o 4-edge evaluation	with 4-edge evaluation
	[rpm]															
for C: A	33,333	30,000	16,667	14,648	8,333	7,324	6,667	5,556	5,000	3,333	3,000	1,667	1,250	938	0.5	2
for K: 0																

### L Interpolation factor = 5

Value for X	Number of lines (Z)														Min. counting frequency of the evaluation electronics (in MHz)	
	900	1,000	1,800	2,048	3,600	4,096	4,500	5,400	6,000	9,000	10,000	18,000	24,000	32,000	w/o 4-edge evaluation	with 4-edge evaluation
	[rpm]															
B	2,222	2,000	1,111	977	556	488	444	370	333	222	200	111	83	63	0.25	1
C	4,444	4,000	2,222	1,953	1,111	977	889	741	667	444	400	222	167	125	0.50	2
D	6,667	6,000	3,333	2,930	1,667	1,465	1,333	1,111	1,000	667	600	333	250	188	0.75	3
E	8,889	8,000	4,444	3,906	2,222	1,953	1,778	1,481	1,333	889	800	444	333	250	1.00	4
G	13,333	12,000	6,667	5,859	3,333	2,930	2,667	2,222	2,000	1,333	1,200	667	500	375	1.50	6
4	17,778	16,000	8,889	7,813	4,444	3,906	3,556	2,963	2,667	1,778	1,600	889	667	500	2.00	8
5	26,667	24,000	13,333	11,719	6,667	5,859	5,333	4,444	4,000	2,667	2,400	1,333	1,000	750	3.00	12
6	33,333	30,000	16,667	14,648	8,333	7,324	6,667	5,556	5,000	3,333	3,000	1,667	1,250	938	4.00	16

### M Interpolation factor = 10

Value for X	Number of lines (Z)														Min. counting frequency of the evaluation electronics (in MHz)	
	900	1,000	1,800	2,048	3,600	4,096	4,500	5,400	6,000	9,000	10,000	18,000	24,000	32,000	w/o 4-edge evaluation	with 4-edge evaluation
	[rpm]															
B	1,111	1,000	556	448	278	244	222	185	167	111	100	56	42	31	0.25	1
C	2,222	2,000	1,111	977	556	488	444	370	333	222	200	111	83	63	0.50	2
D	3,333	3,000	1,667	1,465	833	732	667	556	500	333	300	167	125	94	0.75	3
E	4,444	4,000	2,222	1,953	1,111	977	889	741	667	444	400	222	167	125	1.00	4
G	6,667	6,000	3,333	2,930	1,667	1,465	1,333	1,111	1,000	667	600	333	250	188	1.50	6
R	8,889	8,000	4,444	3,906	2,222	1,953	1,778	1,481	1,333	889	800	444	333	250	2.00	8
S	13,333	12,000	6,667	5,859	3,333	2,930	2,667	2,222	2,000	1,333	1,200	667	500	375	3.00	12
6	17,778	16,000	8,889	7,813	4,444	3,906	3,556	2,963	2,667	1,778	1,600	889	667	500	4.00	16
7	22,222	20,000	11,111	9,766	5,556	4,883	4,444	3,704	3,333	2,222	2,000	1,111	833	625	5.00	20
8	26,667	24,000	13,333	11,719	6,667	5,859	5,333	4,444	4,000	2,667	2,400	1,333	1,000	750	6.00	24

### I Interpolation factor = 25

Value for X	Number of lines (Z)														Min. counting frequency of the evaluation electronics (in MHz)	
	900	1,000	1,800	2,048	3,600	4,096	4,500	5,400	6,000	9,000	10,000	18,000	24,000	32,000	w/o 4-edge evaluation	with 4-edge evaluation
	[rpm]															
B	444	400	222	195	111	98	89	74	67	44	40	22	17	13	0.25	1
C	889	800	444	391	222	195	178	148	133	89	80	44	33	25	0.50	2
D	1,333	1,200	667	586	333	293	267	222	200	133	120	67	50	38	0.75	3
E	1,778	1,600	889	781	444	391	356	296	267	178	160	89	67	50	1.00	4
G	2,667	2,400	1,333	1,172	667	586	533	444	400	267	240	133	100	75	1.50	6
R	3,556	3,200	1,778	1,563	889	781	711	593	533	356	320	178	133	100	2.00	8
S	5,333	4,800	2,667	2,344	1,333	1,172	1,067	889	800	533	480	267	200	150	3.00	12
T	7,111	6,400	3,556	3,125	1,778	1,563	1,422	1,185	1,067	711	640	356	267	200	4.00	16
U	8,889	8,000	4,444	3,906	2,222	1,953	1,778	1,481	1,333	889	800	444	333	250	5.00	20
V	10,667	9,600	5,333	4,688	2,677	2,344	2,133	1,778	1,600	1,067	960	533	400	300	6.00	24

### N Interpolation factor = 50

Value for X	Number of lines (Z)														Min. counting frequency of the evaluation electronics (in MHz)	
	900	1,000	1,800	2,048	3,600	4,096	4,500	5,400	6,000	9,000	10,000	18,000	24,000	32,000	w/o 4-edge evaluation	with 4-edge evaluation
	[rpm]															
B	222	200	111	98	56	49	44	37	33	22	20	11	8	6	0.25	1
C	444	400	222	195	111	98	89	74	67	44	40	22	17	13	0.50	2
D	667	600	333	293	167	146	133	111	100	67	60	33	25	19	0.75	3
E	889	800	444	391	222	195	178	148	133	89	80	44	33	25	1.00	4
G	1,333	1,200	667	586	333	293	267	222	200	133	120	67	50	38	1.50	6
R	1,778	1,600	889	781	444	391	356	296	267	178	160	89	67	50	2.00	8
S	2,667	2,400	1,333	1,172	667	586	533	444	400	267	240	133	100	75	3.00	12
T	3,556	3,200	1,778	1,563	889	781	711	593	533	356	320	178	133	100	4.00	16
U	4,444	4,000	2,222	1,953	1,111	977	889	741	667	444	400	222	167	125	5.00	20
V	5,333	4,800	2,677	2,344	1,333	1,172	1,067	889	800	533	480	267	200	150	6.00	24

### P Interpolation factor = 100

Value for X	Number of lines (Z)														Min. counting frequency of the evaluation electronics (in MHz)	
	900	1,000	1,800	2,048	3,600	4,096	4,500	5,400	6,000	9,000	10,000	18,000	24,000	32,000	w/o 4-edge evaluation	with 4-edge evaluation
	[rpm]															
B	111	100	56	49	28	24	22	19	17	11	10	6	4	3	0.25	1
C	222	200	111	98	56	49	44	37	33	22	20	11	8	6	0.50	2
D	333	300	167	146	83	73	67	56	50	33	30	17	13	9	0.75	3
E	444	400	222	195	111	98	89	74	67	44	40	22	17	13	1.00	4
G	667	600	333	293	167	146	133	111	100	67	60	33	25	19	1.50	6
R	889	800	444	391	222	195	178	148	133	89	80	44	33	25	2.00	8
S	1,333	1,200	667	586	333	293	267	222	200	133	120	67	50	38	3.00	12
T	1,778	1,600	889	781	444	391	356	296	267	178	160	89	67	50	4.00	16
U	2,222	2,000	1,111	977	556	488	444	370	333	222	200	111	83	63	5.00	20
V	2,677	2,400	1,333	1,172	667	586	533	444	400	267	240	133	100	75	6.00	24

## 11.3 Graduated Disk

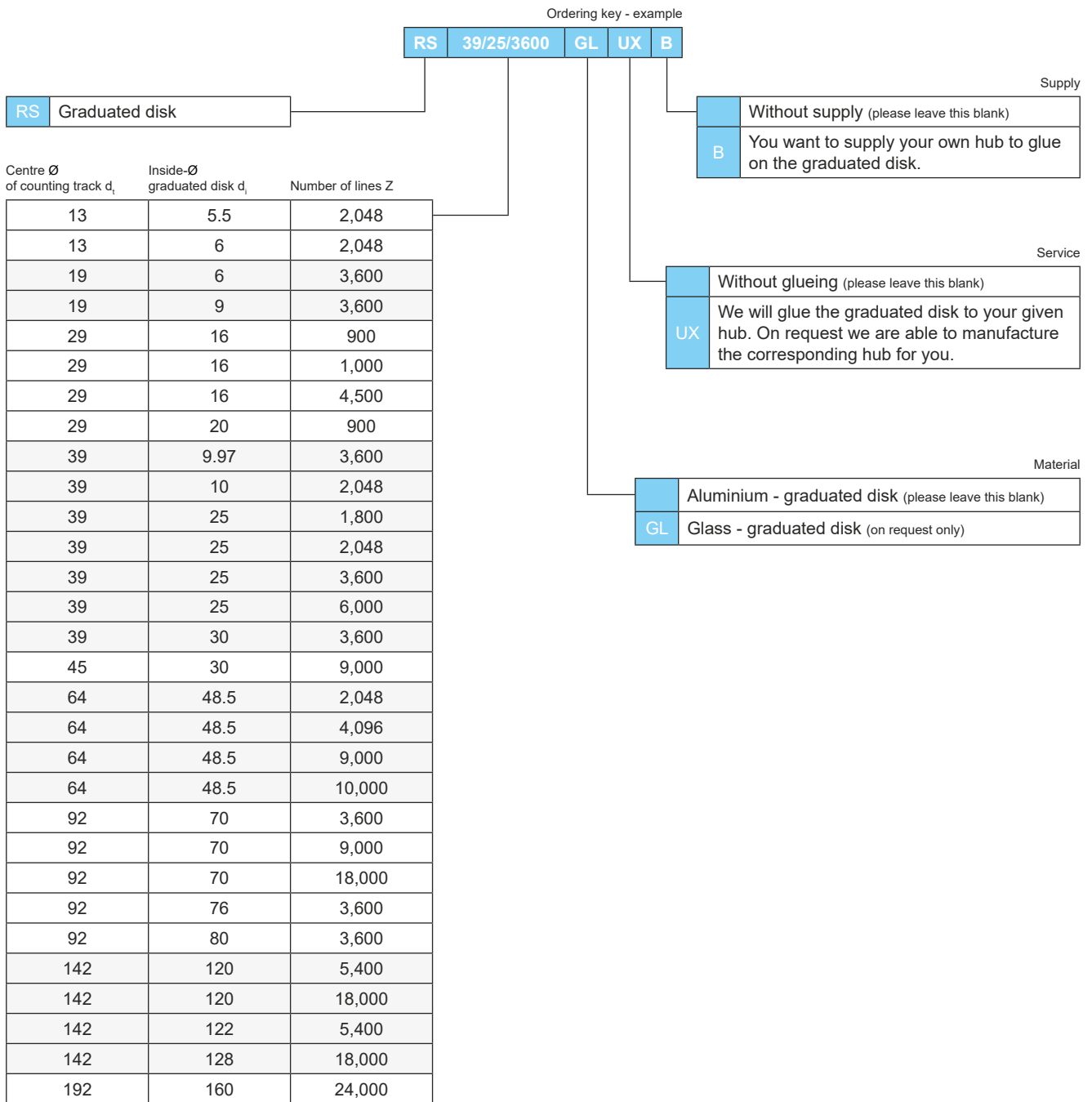

(other sizes on request)

### NOTE

Deviations from the standard configurations listed here are possible in principle. We would be happy to work with you to develop your individual solution. Simply get in touch with your local contact person. You will find a corresponding contact list on our website under "Contact".

## 11.4 ADJUSTMENT TOOL

Name	Scope of delivery / Description	Order-no.
ADJUSTMENT TOOL	<ul style="list-style-type: none"> <li>• ADJUSTMENT TOOL black box</li> <li>• Diagnostic cable to connect the measuring system</li> <li>• USB cable to connect a PC</li> <li>• USB - D-SUB - adapter cable (15-pin)</li> <li>• Exchangeable 8-pin plug connectors</li> </ul>	344220-33

### Optional Single Components

Name	Description	Order-no.
EPIFLEX software - USB flash drive	External flash drive with saved EPIFLEX software	686802-02
USB - D-SUB - adapter cable (15-pin)	to supply the measuring system with voltage via PC	341693-0M
8-pin plug connector	to connect the diagnostic cable to the diagnostic socket	348958-01



USB - D-SUB - adapter cable (15-pin)

Image 31

Required components (not included):

- PC with OS Windows 7, 8, 10 (32 or 64 bit)





**NUMERIK JENA** GmbH  
Im Semmicht 4  
07751 Jena • Germany  
[info@numerikjena.com](mailto:info@numerikjena.com)  
[www.numerikjena.com](http://www.numerikjena.com)

