



Index

1.	Overview	4
2.	Application Examples	4
3.	Safety	5
3.1	General Information	5
3.2	Notes on Legal Requirements	6
3.3	Notes on Transport, Storage and Handling	7
3.4	Notes on Operation	8
3.5	Notes on Maintenance	8
4.	Technical Data	9
4.1	Resolution and Accuracy (Definition)	9
4.2	Mechanical Data	10
4.2.1	Scanning Head	10
4.2.2	Scale Tape	11
4.2.3	SINGLEFLEX and DOUBLEFLEX Scale Tape	11
4.2.4	Cable	13
4.3	Electrical Data	14
4.4	PIN Assignment 15 Pin D-Sub Connector	15
4.5	PIN Assignment 12 Pin JST Mini-Connector	16
4.6	Cable Layout	16
4.7	Electromagnetic Compatibility (EMC)	17
4.8	Shielding Concepts	17
4.9	Ambient Conditions	18
5.	Dimensions and Mounting Conditions	18
5.1	SINGLEFLEX Scale Tape	18
5.2	DOUBLEFLEX Scale Tape	20
5.3	Kit LA Standard Frame - Dimensions	21
6.	Encoder Interfaces	22
6.1	Interface Driver	22
6.2	Interface Driver for EnDat 2.2	22
6.3	EnDat 2.2 Interface	23
6.3.1	Protocol Description	23
6.4	SSI Interface	24
6.4.1	Protocol Description	24
6.4.2	Readout Cycle	24
6.4.3	Multi-Cycle Readout	24
6.5	HIPERFACE Compatible Interface ¹	25
6.5.1	Protocol Description	25
6.5.2	Readout Cycle	25

6.5.3	Device Settings at Delivery	26
6.5.4	Supported Commands	26
6.5.5	Status Codes	27
6.5.6	RS-485 Settings	27
6.5.7	Data field for additional status information	28
6.5.8	Overview error and warning bits	28
6.5.9	Valuation number	28
6.6	BiSS C Interface ²	29
6.6.1	Protocol Description	29
6.6.2	Readout Cycle	29
6.7	Analogue 1 V _{pp} Interface	30
6.8	USB 2.0 Interface	30
6.9	ABSOFLEX USB-Adapter	30
7.	Diagnose and Adjustment Software ABSOFLEX	31
7.1	Installation of the ABSOFLEX Software	31
7.2	Connection of the Measuring System to the ABSOFLEX USB-Adapter	32
7.3	ABSOFLEX - Range of Functions	33
7.4	Evaluation of the Signal Quality	37
7.5	Evaluation of the Mounting Conditions and Automatic Signal Adjustment	38
7.6	Programming of the Logic Zero-Position and Counting Direction	40
8.	General Installation Notes	41
8.1	Delivery Contents	41
8.2	Installation Position	41
8.3	Mounting Steps	42
9.	Cleaning	50
9.1	Measuring System	50
9.2	Scale Tape	50
10.	Troubleshooting	51
10.1	Typical Errors	51
10.2	FAQ	52
10.3	System Check with the ABSOFLEX - Software	53
11.	Ordering Key	54
11.1	Scanning Head	54
11.2	Scale Tape	55

¹ HIPERFACE is a trade mark of SICK Stegmann GmbH

² BiSS is a trade mark of iC-Haus GmbH

1. Overview

Position encoders in drive systems have to meet high and controversial demands, especially in linear drive systems. The demands opposing each other are high accuracy and resolution on the one hand and low mass, small dimensions and high measuring speed on the other hand.

The LAK encoders from NUMERIK JENA are equipped with features that fulfill these high requirements in an ideal manner. The special combination of incremental and absolute encoder does not only guarantee stable operation but also enables high speed measuring with high resolution while still maintaining very small dimensions. Furthermore NUMERIK JENA set great value to customization possibilities during the development. Therefore the LAK measuring system offers a large number of customization options as well as various interfaces:

- Possibility of an electronic adjustment after mounting to reduce static mounting errors
- Kit version for customer-specific housings/frames
- Individual measuring lengths of the scales available (up to 1.20 m)
- Several interfaces usable
- Wide range of supply voltages to compensate conduction losses
- Extensive diagnostic and monitoring functions (e.g. read head temperature)
- High control dynamics due to low calculation time
- Two absolute tracks and two incremental sensors ensure high contamination immunity

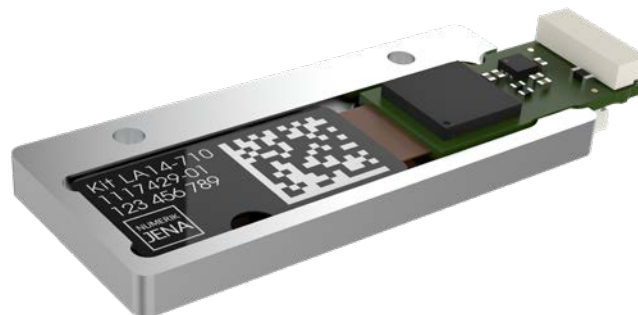

Image 1

2. Application Examples

- Production and inspection machines for the semiconductor industry
- Linear units and linear drives
- Coordinate tables
- Measuring machines and measuring microscopes
- Robotics
- Precision devices in reprography
- Precise machining
- Positioning and measuring devices in medical technology

3. Safety

3.1 General Information

- Make sure to familiarize yourself thoroughly with the contents of these installation instructions before installing and starting up the encoder!
- Please contact the support of NUMERIK JENA GmbH or an authorized representation for further information. Please visit the NUMERIK JENA website to get the contact information.
- NUMERIK JENA GmbH is not liable for damages caused by unauthorized handling of the encoders. Any unauthorized handling leads to forfeiture of all warranty claims.
- The encoders are guaranteed to function if the mounting and operating conditions are maintained as stated in these mounting instructions.
- Make sure to follow the right sequence of the mounting steps during mounting.
- NUMERIK JENA GmbH does not assume any liability for any damages or operating errors caused by incorrect installation or operation.
- The stated tolerances must be maintained in order to achieve the accuracies listed in the specifications!
- If the machine tolerances exceed the tolerances stated in the mounting instructions, errors can occur in both the operation and during measuring. NUMERIK JENA GmbH assumes no liability for this.
- Please refer to the operating manuals and safety instructions included with the devices to ensure the reliable operation of the encoder systems, especially pertaining to:
 - Auxiliary electronic units
 - Counters
 - Displays
 - Controllers
 - Encoders
 - Base mechanical devices (machine tools)
- Please pay attention to the safety instructions and warning symbols!



Danger to the device or to the function of the device!



Pull the plug!



Highly inflammable!

3.2 Notes on Legal Requirements

- The NUMERIK JENA encoders conform to EC standards and carry the CE mark.
- NUMERIK JENA encoders fulfill the requirements of the (German) Product Safety Act (ProdSG) from November 8th, 2011.
- Connect NUMERIK JENA encoders only to subsequent electronics whose power supply is generated from PELV systems (EN 50178).
- NUMERIK JENA encoders fulfill the requirements of standard IEC 61010-1 only if the power is supplied from a secondary circuit with current limitation as per IEC 61010^{3rd Ed.}, Section 9.4 or with power limitation as per IEC 60950-1^{2nd Ed.}, Section 2.5 or from a Class 2 secondary circuit as specified in UL1310.*
- This user manual supersedes all previous editions, which thereby become invalid. The basis for ordering from NUMERIK JENA is always the user manual edition valid when the contract is made.
- Standards (ISO, EN, etc.) apply only where explicitly stated in the user manual.

* In place of IEC 61010-1^{3rd Ed.}, Section 9.4, the corresponding sections of standards DIN EN 61010-1, EN61010-1, UL 61010-1 and CAN/CSA-C22.2 No. 61010-1 can be applied and in place of IEC 60950-1^{2nd Ed.}, Section 2.5 the corresponding sections of standards DIN EN60950-1, EN60950-1, UL60950-1, CAN/CSA-C22.2 No. 60950-1 can be applied.

3.3 Notes on Transport, Storage and Handling



Encoder

- Use the original packaging for transportation only!
- If possible, use the original packaging for storage only.

SINGLEFLEX Scale Tape

- Can be rolled up (minimum bending radius = 140 mm).
- No restrictions regarding to the length.

DOUBLEFLEX Scale Tape

- In no case the DOUBLEFLEX scale tape should be stored, transported or used when rolled up!
- Use only the original packaging for transportation!
 - Lengths up to 3 m - stretched out
 - Lengths above 3 m - tape laid down as a figure eight
- Use the original packaging for storage only!
- Damages to the adhesive layer between the scale tape and carrier tape must absolutely be avoided, since otherwise the measuring properties of the DOUBLEFLEX scale tape are lost.
- Only remove the DOUBLEFLEX scale tape from the packaging on site, directly before mounting.
- Do not separate the scale tape and carrier tape from each other! Avoid any unintentional separation of the scale tape from the carrier tape, even just partial separation.
- Avoid radial or axial offsetting between the scale tape and carrier tape.
- **If the scale tape should become partially or completely separated from the carrier tape - even for just a very short time - simply pressing them together again will not result in sufficient adhesion. In this case neither the operational reliability nor the metrological properties can be guaranteed anymore. Please return the scale tape to NUMERIK JENA GmbH for repair! Unfortunately a repair at the customer site is not possible.**
- When removing the DOUBLEFLEX scale tape from the packaging, the sag must not exceed more than 100 mm.
- After the removal, the greatest distance between two supports must not be more than 800 mm. Scale tapes up to 1,200 mm must be supported approx. 300 mm from the ends and longer scale tapes must be supported correspondingly.

3.4 Notes on Operation



- Do not connect or disconnect plugs if the power is on!
- Only operate the encoder with the supply voltage stated in this product data sheet.
- Comply with applicable PIN assignment if auxiliary electronic units are connected (e.g. controller or display)!
- Integrate exposed encoders in instruments, devices or machines in such a way that these are protected against contamination.
- Protect the scale tape against mechanical damage.
- Protect the scanning head against shock, impact and humidity.

3.5 Notes on Maintenance

- The encoder requires no maintenance whatsoever, but must be cleaned occasionally, depending on the ambient conditions.
- Modifications and repairs of the encoder may only be carried out by NUMERIK JENA GmbH or appropriately authorized persons.
- NUMERIK JENA GmbH is not liable for damages caused by unauthorized handling of the encoder. All warranty claims are forfeited by unauthorized handling.
- Exposed measuring systems are sensitive to contamination, especially the scale surface and the scanning windows on the scanning head.
- Particularly critical are rough and irregular contamination and deposits (e.g. oil, grease or water).
- The user has to protect the encoder from contamination by way of appropriate design measures.



- **When cleaning the encoder, ensure that no solvent flows under the scale tape!**
- **When cleaning the components, ensure that the scanning window and scale tape are not scratched by any deposited particles!**
- **Please also pay attention to the notes in chapter 9 „Cleaning“.**

4. Technical Data

4.1 Resolution and Accuracy (Definition)

Basically one has to differentiate between the resolution and the accuracy of a measuring system. The two parameters are not directly interdependent and may differ from each other.

Resolution

The resolution of linear system describes the least possible displacement of scanning head against the scale which can still be discerned by the evaluation electronics (display, control). It depends on:

- the graduation period of the scale
- the signal interpolation factor (internally or in auxiliary electronic unit)

Accuracy

The accuracy of linear measuring systems is specified in accuracy classes.

The extreme error values for any max. one-meter section of the measured length lie within the specified accuracy class of $\pm a \mu\text{m}$ with respect to their mean value.

For measuring length up to 1 m, the tolerance ($\pm a \mu\text{m}$) refers to the actual measuring lengths. The accuracy applies to a reference temperature of 20°C.

With exposed linear measuring systems, the definition of the accuracy class applies only to the scale. This is called scale accuracy.

4.2 Mechanical Data

4.2.1 Scanning Head

		Kit LA
Dimensions of scan head [mm]	depending on the frame (example: 43.9 x 16 x 5.2)	
Area of sensor glass [mm]	18.7 x 9	
Weight of scan head (w/o cable)	depending on the frame (example: 5.0 g)	
Measuring steps	EnDat 2.2	SSI, HIPERFACE compatible, BiSS C (unidirectional)
	10 nm	1.25 μm 625.0 nm 312.5 nm 156.25 nm 78.125 nm
Max. traversing speed	10 m/s	
Working distance (air gap)	0.85 mm	
Interpolation error	Ideal (perfect mounting conditions)	Typical (within mounting tolerances)
	30 nm _{rms}	50 nm _{rms}
Mounting tolerances scan head with scale tape as reference base	$\Delta Y = \pm 0.5 \text{ mm}$ $\Delta Z = \pm 0.2 \text{ mm}$	$\Delta \varphi X = \pm 0.5^\circ$ $\Delta \varphi Y = \pm 0.5^\circ$ $\Delta \varphi Z = \pm 0.25^\circ$

Chart 1

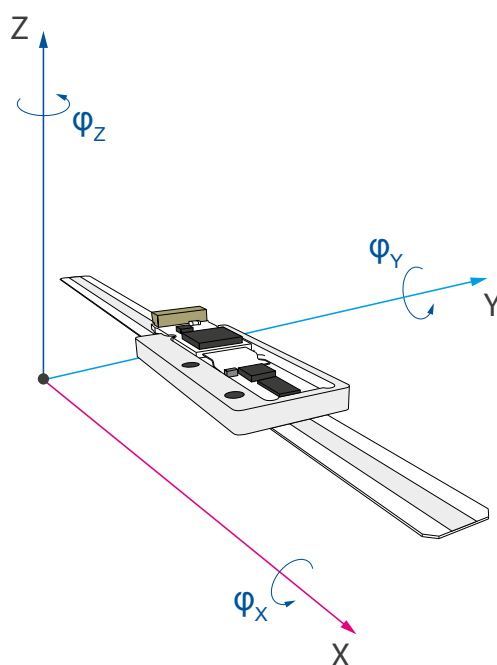

Image 2

4.2.2 Scale Tape

Scale tape	
Material	Stainless steel
Absolute track	Pseudo Random Code (PRC)
Incremental track	20 µm grating period (TP)
Measuring length (ML)	
SINGLEFLEX scale tape	up to 1,20 m (following versions up to 3,8 m)
DOUBLEFLEX* scale tape	up to 1,20 m (following versions up to 3,8 m)
Linear thermal expansion coefficient	
SINGLEFLEX scale tape	$10.6 \times 10^{-6} \text{ K}^{-1}$ (expansion will be influenced by the mounting surface)
DOUBLEFLEX* scale tape	$10.6 \times 10^{-6} \text{ K}^{-1}$
Accuracy class (a)	
SINGLEFLEX, DOUBLEFLEX* scale tape	$\pm 3 \text{ µm}$ (based on a scale tape length of 1 m)

* not suitable for vacuum applications

Chart 2

4.2.3 SINGLEFLEX and DOUBLEFLEX Scale Tape

The steel scale tapes from NUMERIK JENA are available in two different versions:

- SINGLEFLEX
- DOUBLEFLEX (not suitable for vacuum applications)

SINGLEFLEX

The SINGLEFLEX-scale tape consists of a single steel tape with applied incremental and absolute tracks. The scale tape is equipped with a double-sided adhesive tape and can be mounted easily on the machine element.

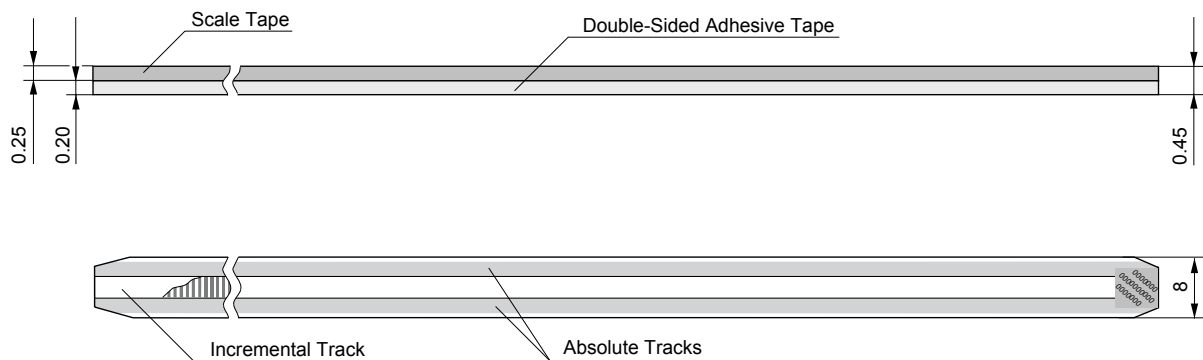

Dimensions in [mm]

Image 3

DOUBLEFLEX

The DOUBLEFLEX-scale tape consists of two superimposed steel tapes. Both of them are divided by a tension uncoupled sheen of oil which ensures the adhesion between the steel tapes. The incremental and absolute tracks are applied on the upper steel tape. The lower steel tape is equipped with a double-sided adhesive tape and can be mounted easily on the machine element.

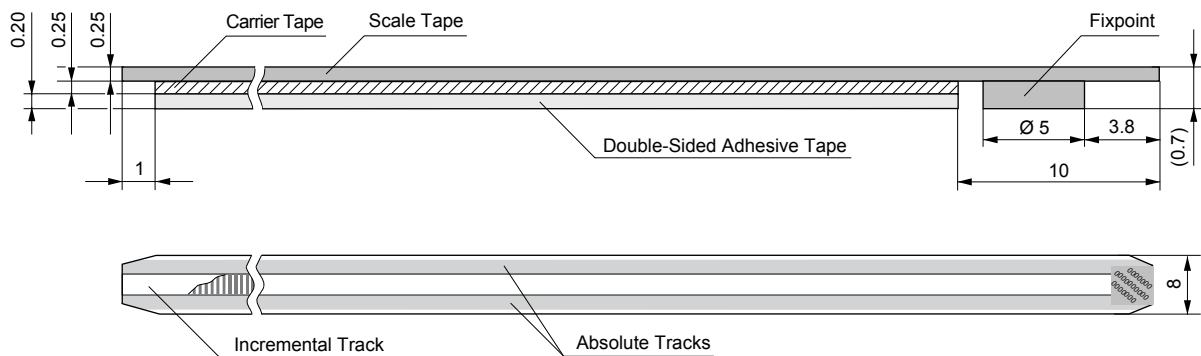

Dimensions in [mm]

Image 4

The two steel tapes are uncoupled mechanically. This ensures that the upper steel tape can expand independently of the lower steel tape due to thermal variations of the ambient temperature. By reference of the ambient temperature and the expansion coefficient of the steel tape it is possible to determine occurring length deviation of the increments. This allows to subtract out the deviation of the measurement results.

4.2.4 Cable

Cable	
Cable diameter	3.7 mm
Permissible bending radius	<ul style="list-style-type: none"> Occasional flexing ~8 mm Constant flexing ~40 mm
From scan head to the D-Sub connector	0.3 m, 0.5 m, 1.0 m, 1.5 m, 2.0 m, 3.0 m (other on request)
From D-Sub connector to the controller (extension cable)	max. 100 m (The necessary supply voltage must be ensured!)

Chart 3

Scanning Head Cable (Connection Cable from Scanning Head to D-Sub Connector)

- Please mount the scanning head preferably on the rigid part and the scale tape on the mobile part of the machine. If this is not possible, provide a strain relief for the cable near the scanning head.
- The encoder cables and connecting cables must be laid away from sources of interference (e.g. mains cables, fuses, motors, magnetic valves or power supplies). Normally a distance of ≥ 100 mm will be sufficient.
- Install the cable in a way that it cannot be damaged by the moving carriage. Please pay attention to the permissible bending radius!

Extension Cable (Connection Cable from D-Sub Connector to Controller)

- Use preferably original extension cables made by NUMERIK JENA. This guarantees an optimum compatibility with the encoders and ensures a maximum protection against electromagnetic interferences.
- Please consult the technical support of NUMERIK JENA before using selfmanufactured extension cables.
- Do not install any other signal lines in the encoder cable!

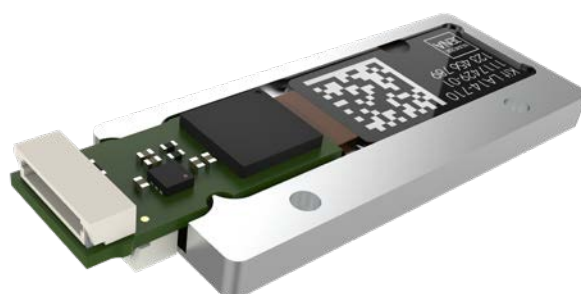

Image 5

4.3 Electrical Data

EnDat 2.2			
Parameter	Min.	Typ.	Max.
Supply voltage (at connector)	3,6 V	5,0 V	14,0 V
Current consumption*	-	285 mA	300 mA
Power Consumption*	-	1,425 W	4,2 W
Calculation time	≤5 μs		
Max. boot time at power-on	300 ms		
Output interfaces	Serial: • EnDat 2.2 Usable simultaneously: • USB 2.0 (diagnostics and user interface)		

Chart 4

SSI, HIPERFACE compatible, BiSS C (unidirectional)			
Parameter	Min.	Typ.	Max.
Supply voltage (at scanning head)	3,5 V	5,0 V	5,5 V
Current consumption*	-	100 mA	125 mA
Power Consumption*	-	500 mW	687,5 mW
Calculation time	≤1 μs		
Max. boot time at power-on	300 ms		
Output interfaces	Serial: • SSI • HIPERFACE compatible interface ¹ • BiSS C (unidirectional) interface ² Usable simultaneously: • USB 2.0 (diagnostics and user interface) • 1 V _{PP} (SIN+, COS+, SIN-, COS-) ³		

Chart 5

* Current and power consumption are dependent on used interfaces due to load variation on internal driver modules.

¹ HIPERFACE is a trade mark of SICK Stegmann GmbH

² BiSS is a trade mark of iC-Haus GmbH

4.4 PIN Assignment 15 Pin D-Sub Connector

EnDat 2.2																
PIN	1	2	3	4	5	6	7	8	9	10	11	12	13	14	15	Housing
Signal	-	0 V	-	5 V	DAT+	-	USBD-	CLK+	-	-	-	-	DAT-	USBD+	CLK-	Shield

Each differential pair of wires is twisted, Cable-Ø = 3.7 mm

Chart 6



Image 6

SSI, HIPERFACE compatible, BiSS C (unidirectional)																
PIN	1	2	3	4	5	6	7	8	9	10	11	12	13	14	15	Housing
Signal	U_{1+}	0 V	U_{2+}	5 V	DAT+	-	USBD-	CLK+	U_{1-}	-	U_{2-}	-	DAT-	USBD+	CLK-	Shield
Color	green	blue	white green	brown green	grey	-	black	violet	brown	-	white	-	pink	red	yellow	-

Each differential pair of wires is twisted, Cable-Ø = 3.7 mm

Chart 7



Image 7

4.5 PIN Assignment 12 Pin JST Mini-Connector

PIN X ₁	1	2	3	4	5	6						
PIN X ₂							1	2	3	4	5	6
Signal	U ₂₋	U ₂₊	U ₁₋	U ₁₊	USBD-	USBD+	Sdata-	Sdata+	Sclk-	Sclk+	5 V	0 V
Color	white	white green	brown	green	black	red	pink	grey	yellow	violet	brown green	blue
PIN X ₃	1	2	3	4	5	6	7	8	9	10	11	12

Each differential pair of wires is twisted.

Chart 8

1 V_{PP}

U₁₊ Counting signal 0° (sin)

U₁₋ Counting signal 180° (-sin)

U₂₊ Counting signal 90° (cos)

U₂₋ Counting signal 270° (-cos)

0 V Ground (GND)

5 V Operating voltage (U_B)

4.6 Cable Layout

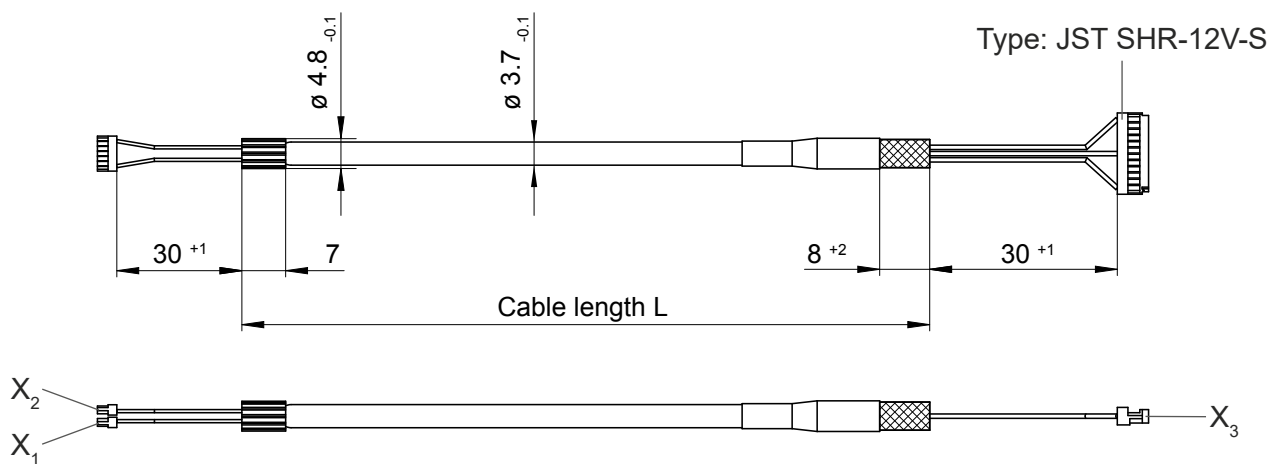

Tolerance cable length L: L < 1 m: L + 10 mm
L > 1 m: L + 30 mm

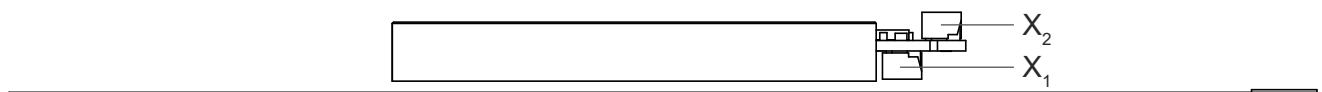

Image 8

4.7 Electromagnetic Compatibility (EMC)



Please observe the following to ensure maximum protection against electrical and magnetic fields:

- The encoder must be mounted to a galvanic conductive surface. The mounting surfaces, the threads of the mounting screws and the threads in the machine must be free from electrically non-conductive coatings.
- Maintain the NUMERIK JENA shielding concept for the measuring system (see also Image 9)!
- Shielding for encoders without connectors:
 - When connected directly with the evaluation electronics, ensure that the external shield of the cable is well grounded
 - If cable connectors (e.g. terminal strips, etc.) are used, connect the external shields of the cables with each other and with the shielding of the cable connector
- When using additional electronics, connect the housing electrically conducting to ensure good galvanic conductivity. For insulated installation the housing should be connected at the shortest distance by an additional potential equalization line (Cu line with cross section $\geq 6 \text{ mm}^2$) with the machine's protective ground.
- Please contact the NUMERIK JENA support or that of the appropriate manufacturer if you experience any problems when working with specific display or control units.

4.8 Shielding Concepts

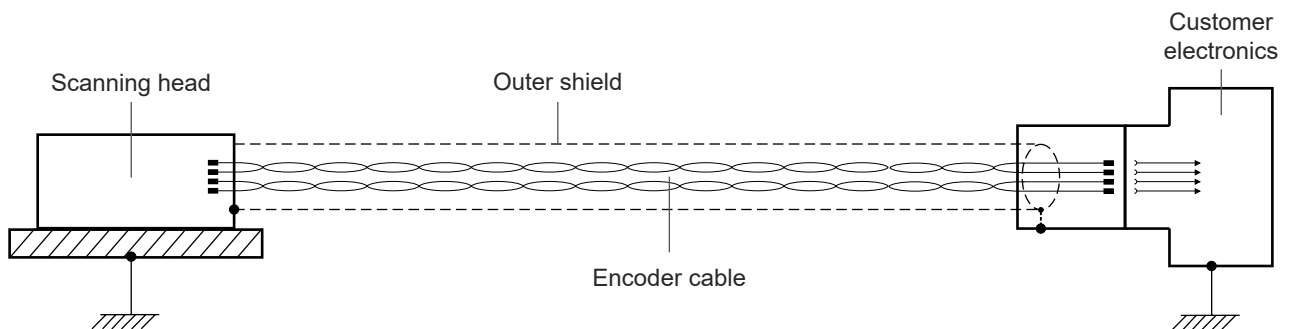

Image 9

4.9 Ambient Conditions

	LAK
Operating temperature range	0°C to +55°C (+32°F to +131°F)
Storage temperature range	-20°C to +70°C (-4°F to +158°F)
Vibration (50 Hz ... 2,000 Hz)	≤200 ms ⁻² (20 g)
Shock (11 ms)	≤400 ms ⁻² (40 g)
Humidity	93% relative humidity (non-condensing)

Chart 9

5. Dimensions and Mounting Conditions

5.1 SINGLEFLEX Scale Tape

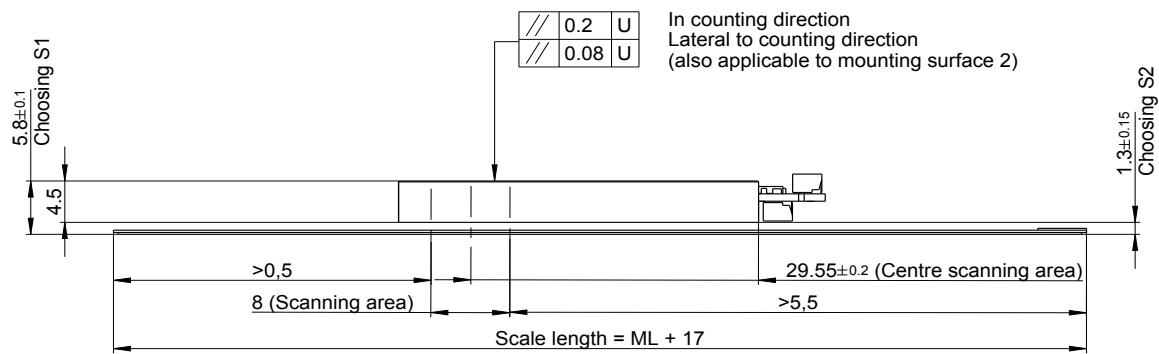

Example Kit LA with Standard Frame

M =

	0.03 / Mounting surface (S)
--	-----------------------------

U =

	0.05/100
	0.05 F

F	Machine guideway
U	Ground surface that supports SINGLEFLEX, DOUBLEFLEX scale tape
S	Mounting surface
M	Mounting surface of the machine for chosen mounting surface S1 or S2
ML	Measuring length

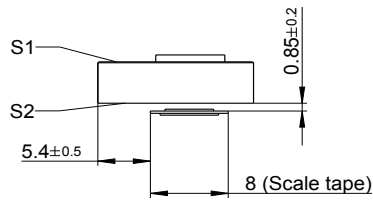

Example Kit LA with Standard Frame

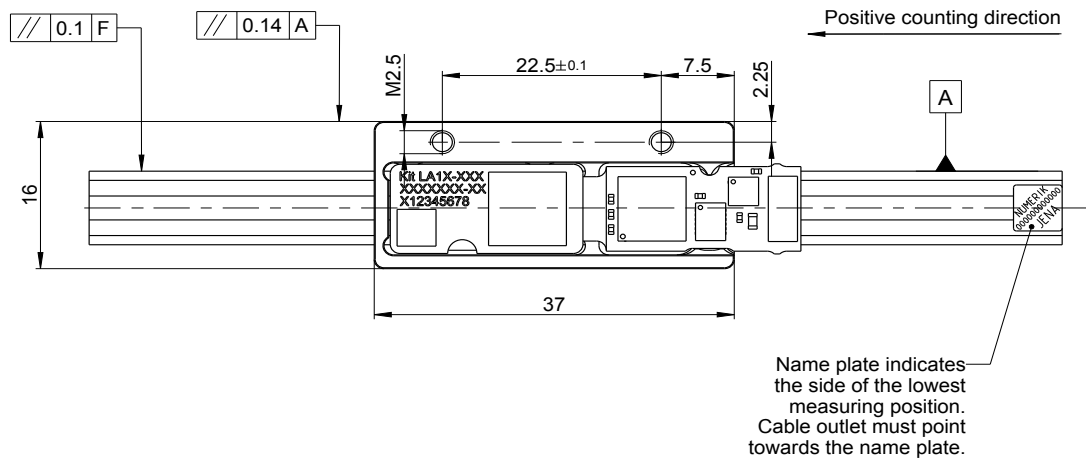

M =  0.03 / Mounting surface (S)

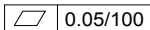
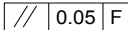
U = 
 0.05 F

F	Machine guideway
U	Ground surface that supports SINGLEFLEX, DOUBLEFLEX scale tape
S	Mounting surface
M	Mounting surface of the machine for chosen mounting surface S1 or S2
ML	Measuring length

5.2 DOUBLEFLEX Scale Tape

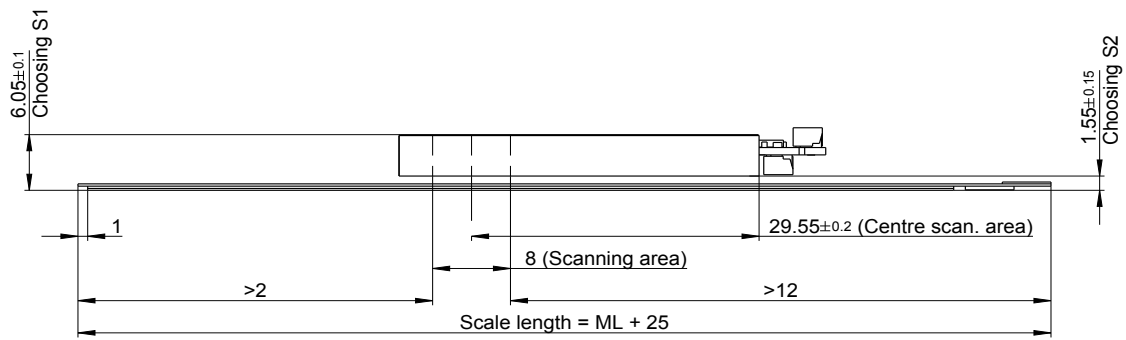

Example Kit LA with Standard Frame

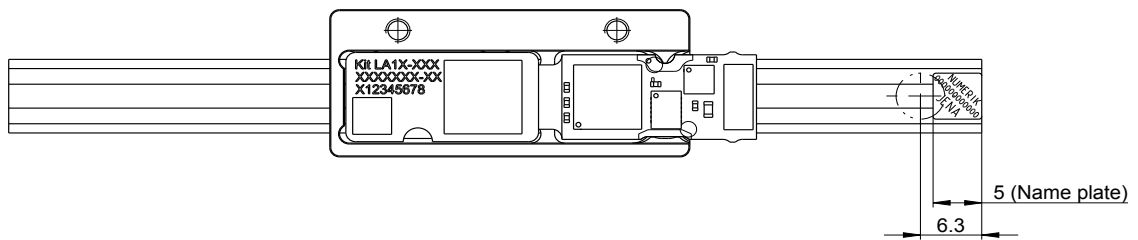

ML - measuring length

5.3 Kit LA Standard Frame - Dimensions

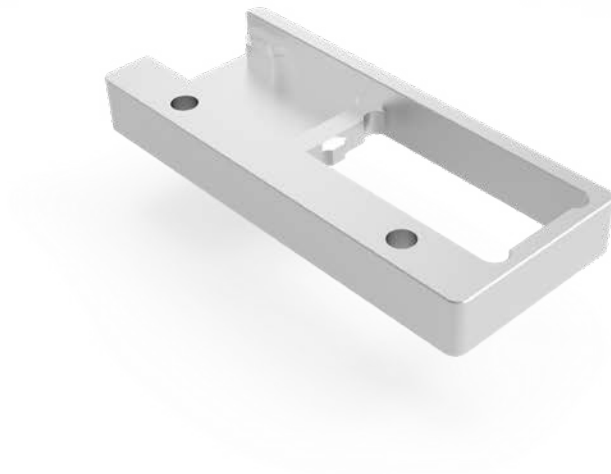
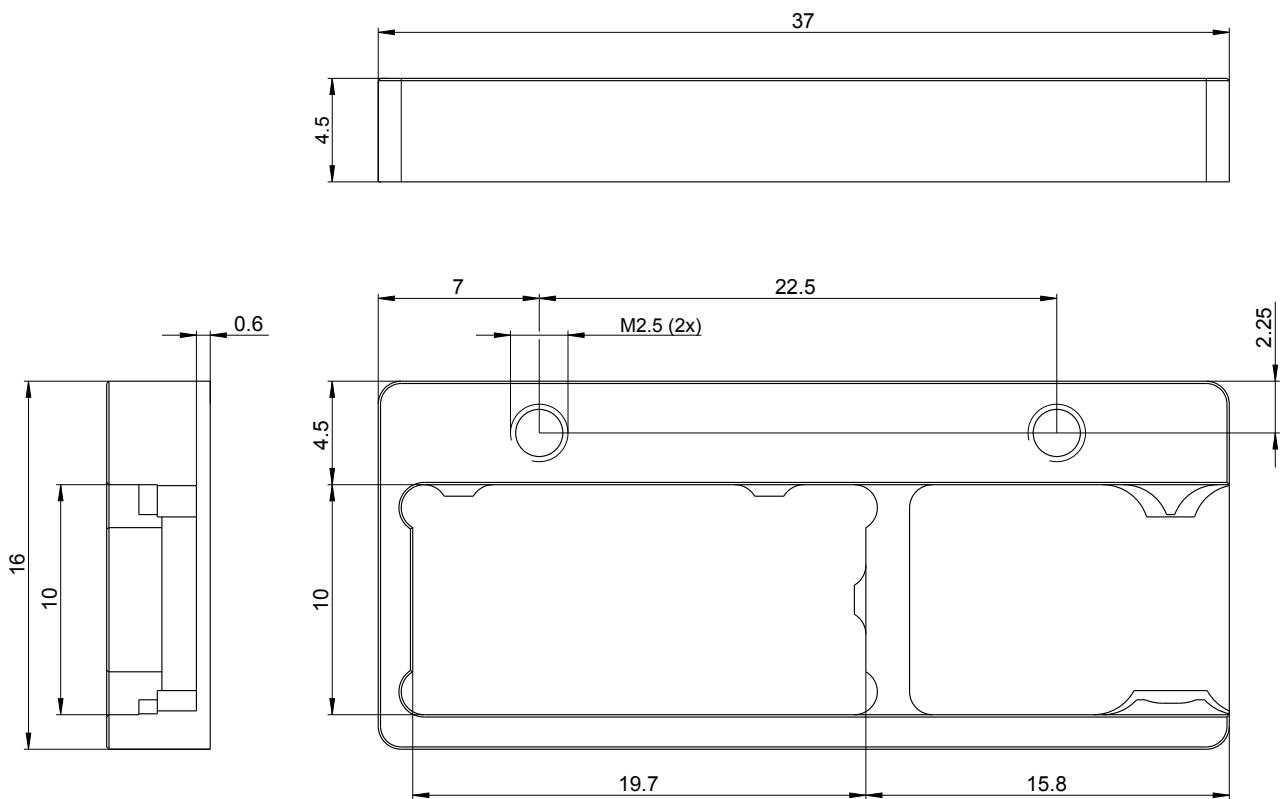

Image 10



6. Encoder Interfaces

6.1 Interface Driver

The interface driver circuit is displayed in the following figure. The differential transmission lines have to be terminated on the customer's side (Typ.: $R = 120 \Omega$).

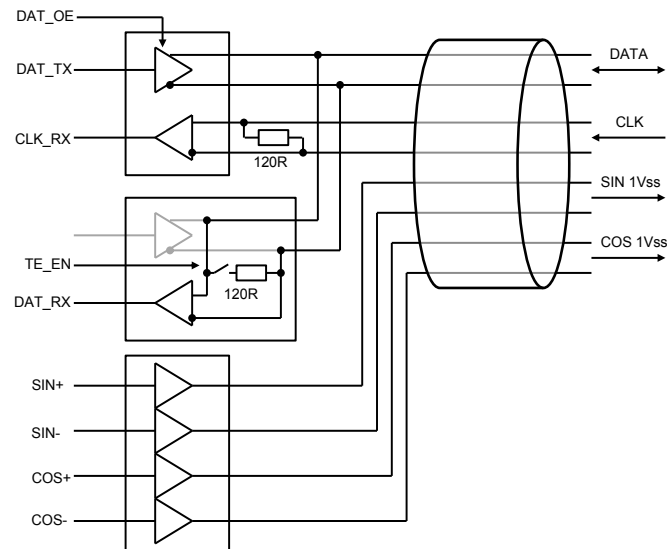

Image 11

6.2 Interface Driver for EnDat 2.2

The interface driver circuit is displayed in the following figure. The differential transmission lines have to be terminated on the customer's side (Typ.: $R = 120 \Omega$).

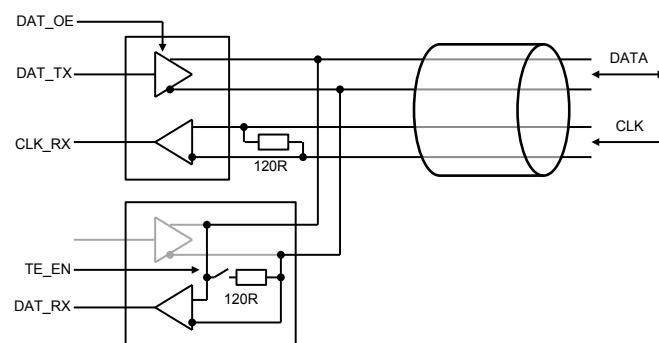

Image 12

6.3 EnDat 2.2 Interface

The EnDat interface from HEIDENHAIN is a digital, bidirectional interface for encoders. It is capable both of transmitting position values from incremental and absolute encoders as well as transmitting or updating information stored in the encoder, or saving new information.

Thanks to the serial transmission method only four signal lines are required. The data are transmitted in synchronism with the clock signal from the subsequent electronics. The type of transmission (position values, parameters, diagnostics, etc.) is selected by mode commands that the subsequent electronics send to the encoder.

6.3.1 Protocol Description

Parameter	Value
Position word	32 bit
Mono flop time	5 μ s
Max. clock frequency	16 MHz

Chart 10

Further information and data sheets regarding the EnDat 2.2 interface are available on the website of the Dr. Johannes Heidenhain GmbH „www.heidenhain.com“.

6.4 SSI Interface

The SSI interface is a serial, synchronous protocol which supports position and error transmission exclusively. Due to its simple structure, integration on the customer's side is easy.

For verification purposes of the received position value, multi-cycle readout is supported.

6.4.1 Protocol Description

Parameter	Value
Position word	25 (Position bits = 24 + leading „0“, starts with MSB) 33 (Position bits = 32 + leading „0“, starts with MSB)
Mono flop time	5 μ s, 10 μ s or 20 μ s
Max. clock frequency	2.0 MHz
Number format (gray/binary)	binary
Parity bits	none
Multi-cycle readout	yes
Error signaling	DAT = High, if critical errors occur, High remains until reset

Chart 11

6.4.2 Readout Cycle

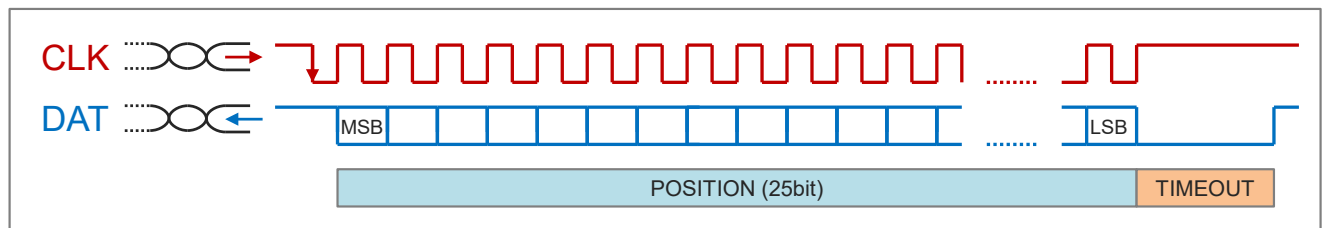

Image 13

When the first falling edge is detected, the position value is loaded into the output register. Every rising edge provides a single bit at the output which can be taken over with the following falling edge.

When the last bit is taken over the data line level is "low". Once the mono flop time passes, the protocol goes back into Idle-mode and waits for a new cycle.

6.4.3 Multi-Cycle Readout

To verify that the data transmission works properly it is possible to read the same position information multiple times without changing it. In order to do that new clock cycles have to be applied during the mono flop time. The position information will be provided repeatedly by the feedback shift register.

6.5 HIPERFACE Compatible Interface¹

6.5.1 Protocol Description

Parameter	Value
Position word	4 x 8 Bit starting with LSB, 24 Bit position value + leading zeroes
Timeout time	11 / baud rate and 44 / baud rate
Max. clock frequency	921600 kHz, smaller baud rates adjustable
Number format (gray/binary)	binary
Parity bits	none, even, odd
Check sum	yes, EXOR operation on transmitted Bytes
User access memory	approx. 2 kByte dividable in arrays of 16 to 128 Bytes

Chart 12

6.5.2 Readout Cycle

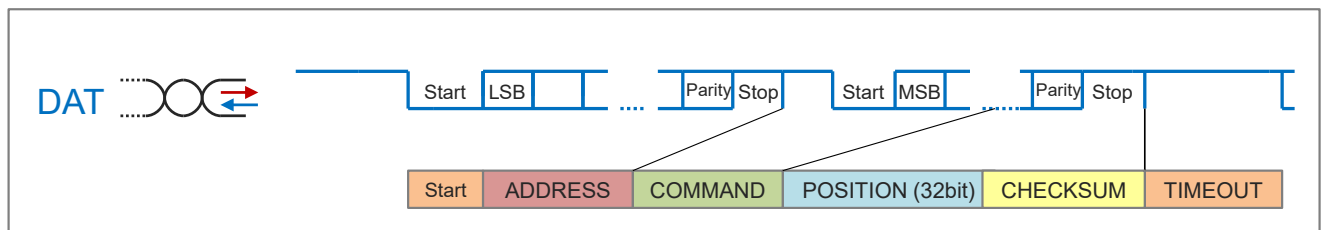

Image 14

The figure above shows a response of the measuring system to a position request. When the falling edge of the start bit is detected the position value is loaded into the output register. The communication on a HIPERFACE¹ compatible bus always begins with the device address, followed by a command, data to be transmitted and a check sum.

It is possible to add a parity bit to every byte transmitted. Each of those is followed by a stop bit. The time between two bytes in a transmission cycle has to be smaller than the set timeout. Once the timeout passes the device expects a new command.

¹ HIPERFACE is a trade mark of SICK Stegmann GmbH

6.5.3 Device Settings at Delivery

Unit type (Kommando 52h)	FFh
Available EEPROM-storage [Bytes]	1024
Unit address	40h
Interface mode	E4h
Access codes 0 .. 3	55h
Counter	0

Chart 13

6.5.4 Supported Commands

Command	Function	Code 0	Comment
42h	Read position		20µm; 8 Bit per Sine-/Cosine period
43h	Set position	x	
44h	Read analogue value		Channel no. 40h: Temperature [°C]
46h	Read counter		
47h	Increment counter		
49h	Delete counter	x	
4Ah	Read data		
4Bh	Store data		
4Ch	Determine status of a data field		
4Dh	Create data field		
4Eh	Determine available memory area		
4Fh	Change access code		
50h	Read encoder status		
52h	Read out type label		Unit type = FFh
53h	Encoder reset		
55h	Allocate encoder address	x	
56h	Read SN and program version		
57h	Configure serial interface	x	
67h	Temporarily configure serial interface		

Chart 14

6.5.5 Status Codes

Category	Code	Description	Commands
	00h	No error	
	03h	Partition table damaged	4Ah,4Bh,4Ch,4Dh,4Eh
Interface	09h	Parity error	all
	0Ah	Check sum error	all
	0Bh	Command unknown	all
	0Ch	Invalid number of data bytes	all
	0Dh	Invalid argument	all
Data	0Eh	the field is write-protected	4Bh
	0Fh	Wrong access code	43h,49h,4Ah,4Bh,4Dh,4Fh,55h,57h
	10h	Field size cannot be changed	4Dh
	11h	Address is outside the field	4Ah,4Bh
	12h	Invalid array number	4Ah,4Bh,4Ch,4Dh
	13h	Not enough free memory	4Dh
	14h	Max. number of data arrays reached	4Dh
	15h	EEPROM error while reading	47h,49h,4Bh,4Dh,4Fh,55h,57h
Position	20h	Error while reading absolute track	independent
	21h	Connection error during absolute track evaluation	independent
	22h	Error in incremental channel	independent
	1Eh	Device temperature too high	independent

Chart 15

6.5.6 RS-485 Settings

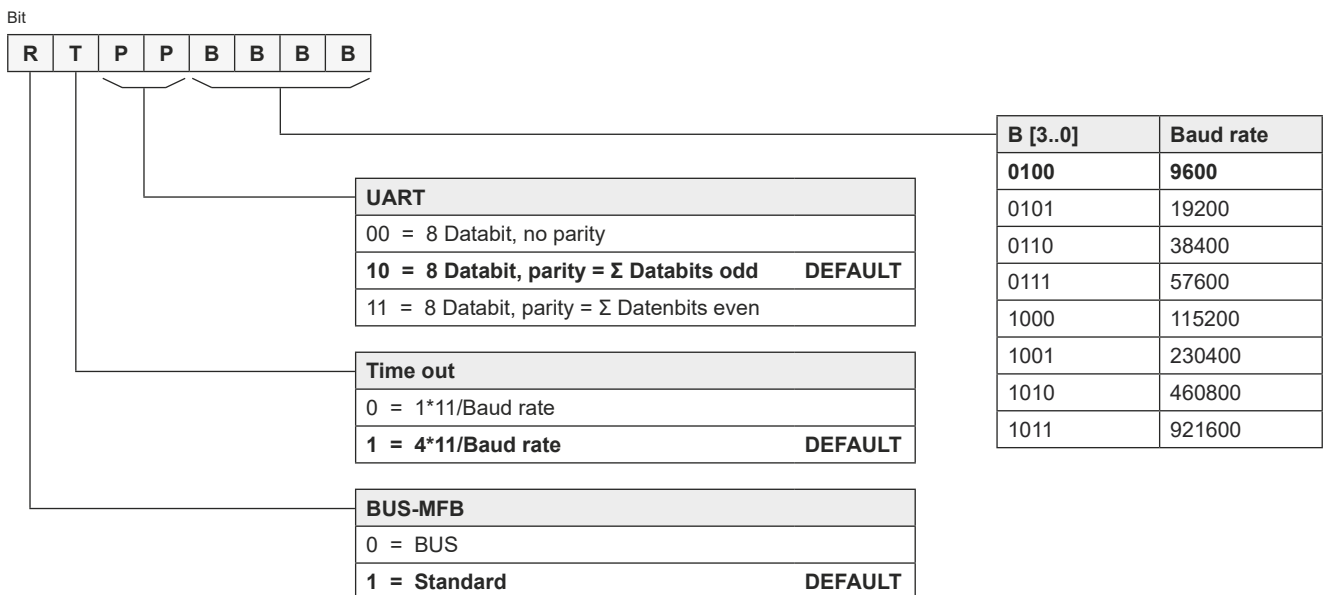

6.5.7 Data field for additional status information

In addition to the predefined data field FFh, which contains the type plate, there is another data field FEh in the Kit LA with additional status information. This field has the following structure:

Adress	Description	Bytes
00h - 01h	Device temperature in C°	2
02h - 03h	Error/warning bits (see chart „Overview error and warning bits“)	2
04h - 05h	Firmware revision	2
06h	Firmware version, 1 st digit = major version, 2 nd digit = minor version	1
07h	Valuation number (system reserve) absolute track	1
08h	Valuation number (system reserve) incremental track	1
09h	Valuation number (system reserve) code connection	1

Chart 16

6.5.8 Overview error and warning bits

Bit	Description
0	PRC decoding failed
1	Code connection failed
2	Malfunction in the incremental system
3	Incremental signals out of tolerance
4	EEPROM checksum error
5	Temperature too high
6	Note: Travel speed too high for absolute system This is not an error. The system continues to work properly.

Chart 17

6.5.9 Valuation number

The valuation numbers correspond to the values displayed on the main screen of the ABSOFLEX software. A description can be found in the section „Evaluation of signal quality“ in the ABSOFLEX operating instruction.

6.6 BiSS C Interface²

The unidirectional *BiSS* protocol² provides additional WARN and ERROR Bits additionally to the SSI protocol. A CRC-6 check sum has been added to ensure safe transmission of data.

6.6.1 Protocol Description

Parameter	Value
Position word	24 (starts with MSB) 32 (starts with MSB)
Timeout time	20 μ s
Acknowledge time	equals calculation time
Max. clock frequency	2.0 MHz (without line delay compensation) 5.0 MHz (with line delay compensation)
ERROR Bit, aktive Low 1 - no error, 0 - error	if critical errors occur, 0 remains until reset
WARN Bit, aktive Low 1 - no warning, 0 - warning	if critical warnings occur, 0 remains for the duration of the warning
Check sum	industry standard CRC-6 (starts with MSB) Polynomial: $x^6 + x^1 + x^0$ Seed: 0x00

Chart 18

6.6.2 Readout Cycle

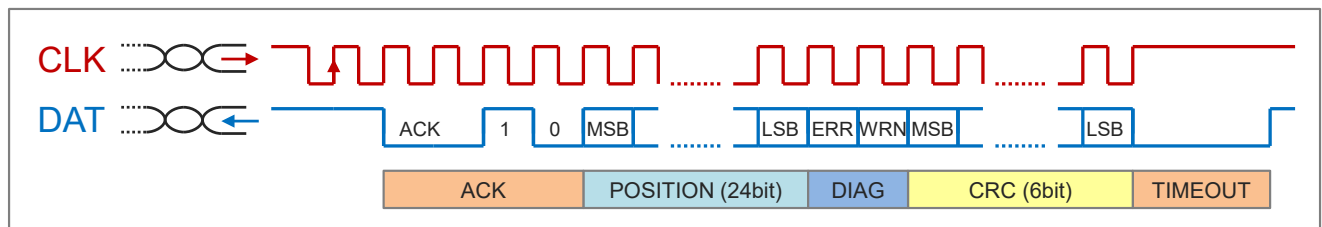

Image 15

The readout starts with two rising edges from the master. The position is sampled at the first rising edge. Necessary operations are made during acknowledge time. The following start bit initiates the data transmission.

Every rising edge provides a bit at the output, which can be taken over when a falling edge is detected.

When the last bit is taken over the data line level is "low". Once the mono flop time passes, the protocol goes back into Idle-mode and waits for a new cycle.

² *BiSS* is a trade mark of iC-Haus GmbH

6.7 Analogue 1 V_{pp} Interface

Schematic

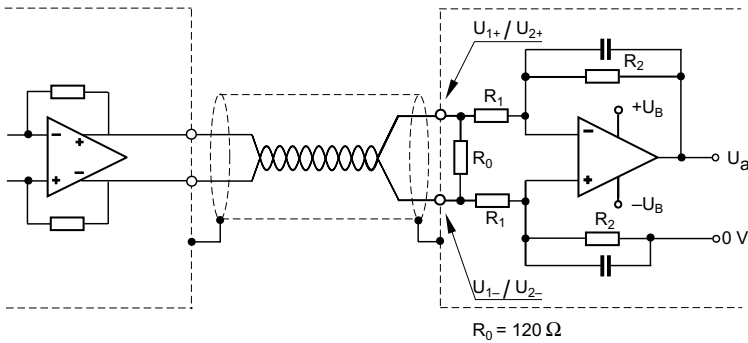

Signal pattern

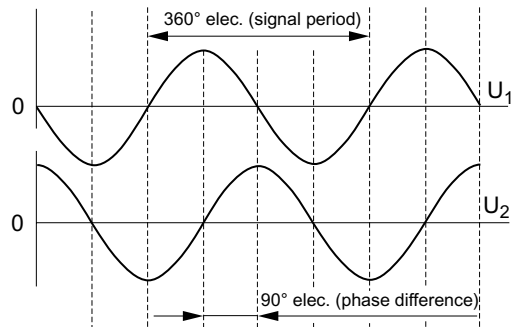

Image 16

Parameter	Min.	Typ.	Max.
Signal $U_1 = U_{1+} - U_{1-}$ (0°)	0.6 V _{pp}	1.0 V _{pp}	1.2 V _{pp}
Signal $U_2 = U_{2+} - U_{2-}$ (90°)	0.6 V _{pp}	1.0 V _{pp}	1.2 V _{pp}
Signal period	20 μ m		
Phase difference	90°		
Cut-off frequency 3 dB	-	-	500 kHz

Chart 19

6.8 USB 2.0 Interface

USB 2.0 is integrated in the Kit LA read head, which allows to have access to the read head via diagnostic software.

An adapter can be used to connect the encoder to a PC for configuration purposes. It is also possible to pick off data by an adapter between the Kit LA connector and the controller.

Once the connection is established the user has several options (please see chapter 7).

6.9 ABSOFLEX USB-Adapter

The absolute encoders from NUMERIK JENA provide a USB 2.0 interface which allows the user to connect it to a PC and use the ABSOFLEX software.

The ABSOFLEX USB-Adapter allows to connect the encoders D-Sub connector directly to a USB port.



Image 17

7. Diagnose and Adjustment Software ABSOFLEX

The measuring systems supplied by NUMERIK JENA were tested and adjusted under ideal mounting conditions. The sensor modules from NUMERIK JENA offer the possibility of electronic adjustment. This lets you adapt the encoder optimally to its surroundings after it has been mounted.

NUMERIK JENA provides the diagnose software ABSOFLEX and a driver package for Kit LA.

Software - Range of Functions:

- Evaluation of the signal quality (absolute and incremental track)
- Evaluation of the mechanical mounting conditions
- Diagnostics of internal read head signal via system margins (0% ... 100%)
- Automatic adjustment of the signals to reduce the effects of static mounting errors
- Programming of the sensor module (zero position and counting direction)*
- Retrieval of position information (position indicator)
- Diagnostics and monitoring

The ABSOFLEX Software is suitable for the following NUMERIK JENA - products:

- Kit LA
- LAK

Supported Operating Systems:

- Windows 7, 8 (32 and 64 bit)
- .NET Framework 4.0

Required Components (not included):

- ABSOFLEX USB-Adapter

7.1 Installation of the ABSOFLEX Software

In general it is not necessary to install the ABSOFLEX software. The software can be executed directly from an external drive. However it is necessary to install the USB device driver through the Windows Device Manager.

The ABSOFLEX software (incl. driver package) can be downloaded for free on the NUMERIK JENA website. Visit the Kit LA product page or the download section.

* Not in combination with EnDat 2.2

7.2 Connection of the Measuring System to the ABSOFLEX USB-Adapter

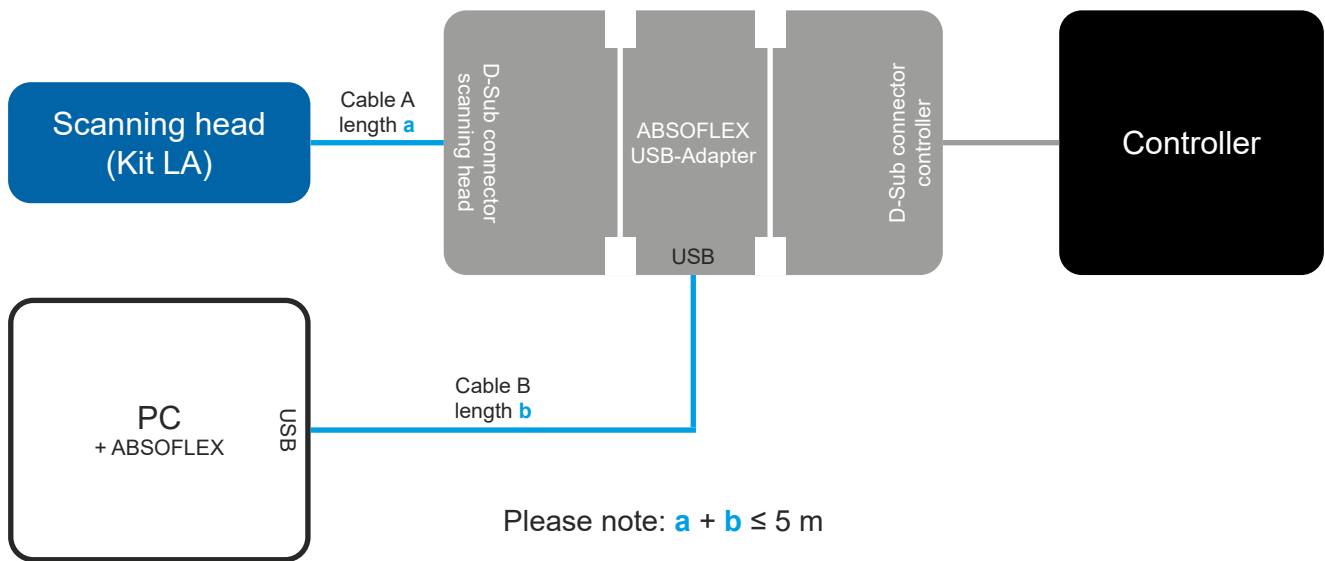

Image 18



ATTENTION! Please pay attention to the following during the signal adjustment:

During the signal adjustment the signals of the encoder should not be used to control the drive motor. Unintentional incorrect signal settings could cause wrong signal values in the controller and therefore lead to malfunction of the drive system.

The stage should be moved without motorized drive during the signal adjustment. If a motorized drive is necessary, a manual operation has to be used and the encoder feedback must not be used.

The total length of cable A + B must not be longer than 5 m (see Image 18).

For the use of the ABSOFLEX software a connection to a controller is not necessary.

7.3 ABSOFLEX - Range of Functions

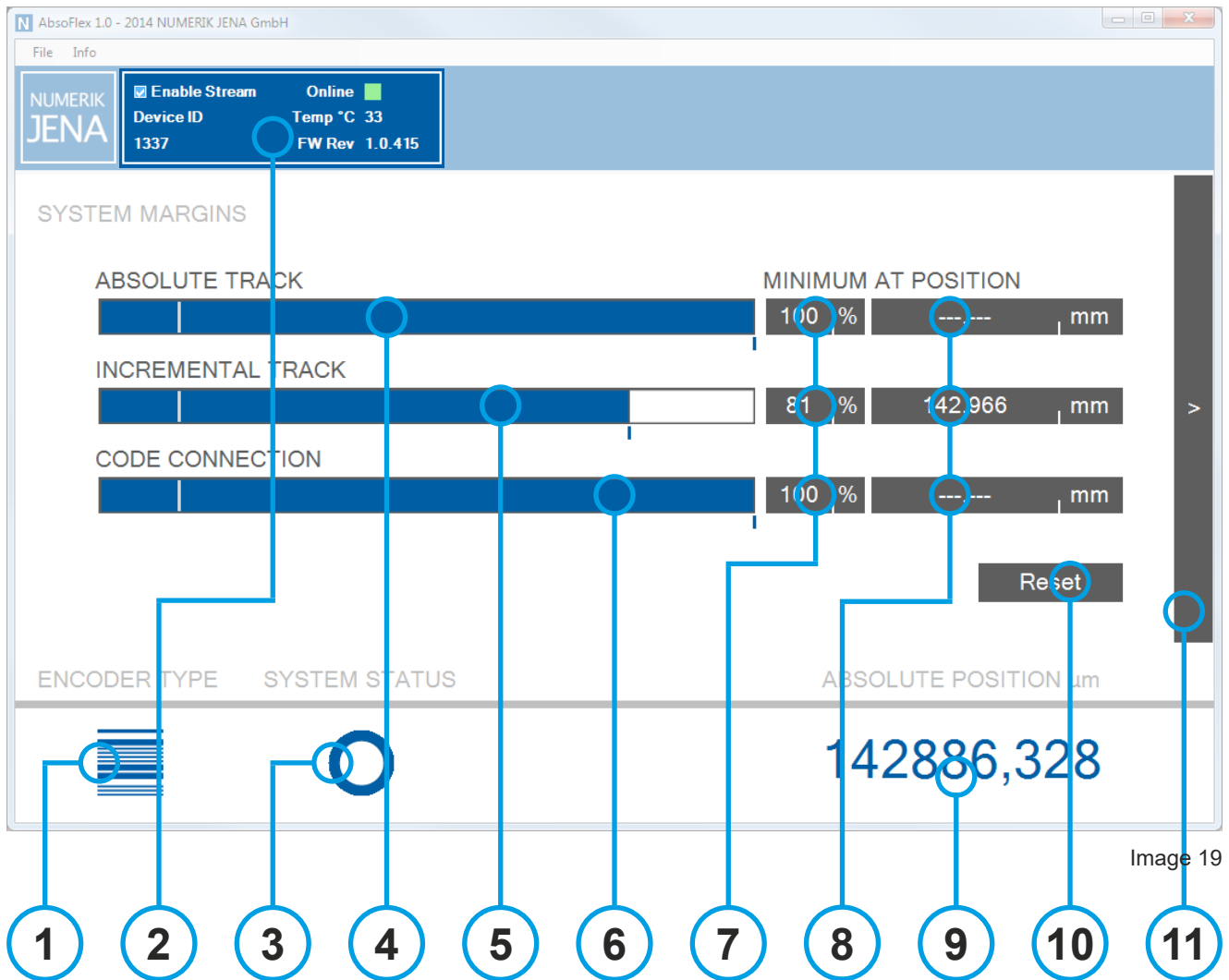

- 1 Display for encoder type (e.g.: linear)
- 2 Status display (shows serial number, firmware version, temperature, connection status)
- 3 Cumulated system status (turns from blue to red in case of an error)
- 4 System margin for absolute track
- 5 System margin for incremental track
- 6 System margin for code connection (absolute + incremental track)
- 7 Display for worst system margin after reset
- 8 Display of the position, where the worst system margin was detected
- 9 Display for the metric absolute position
- 10 Reset - Button: system reset when errors occur
- 11 Shift - Button: switches to the adjustment panel

Signal Adjustment

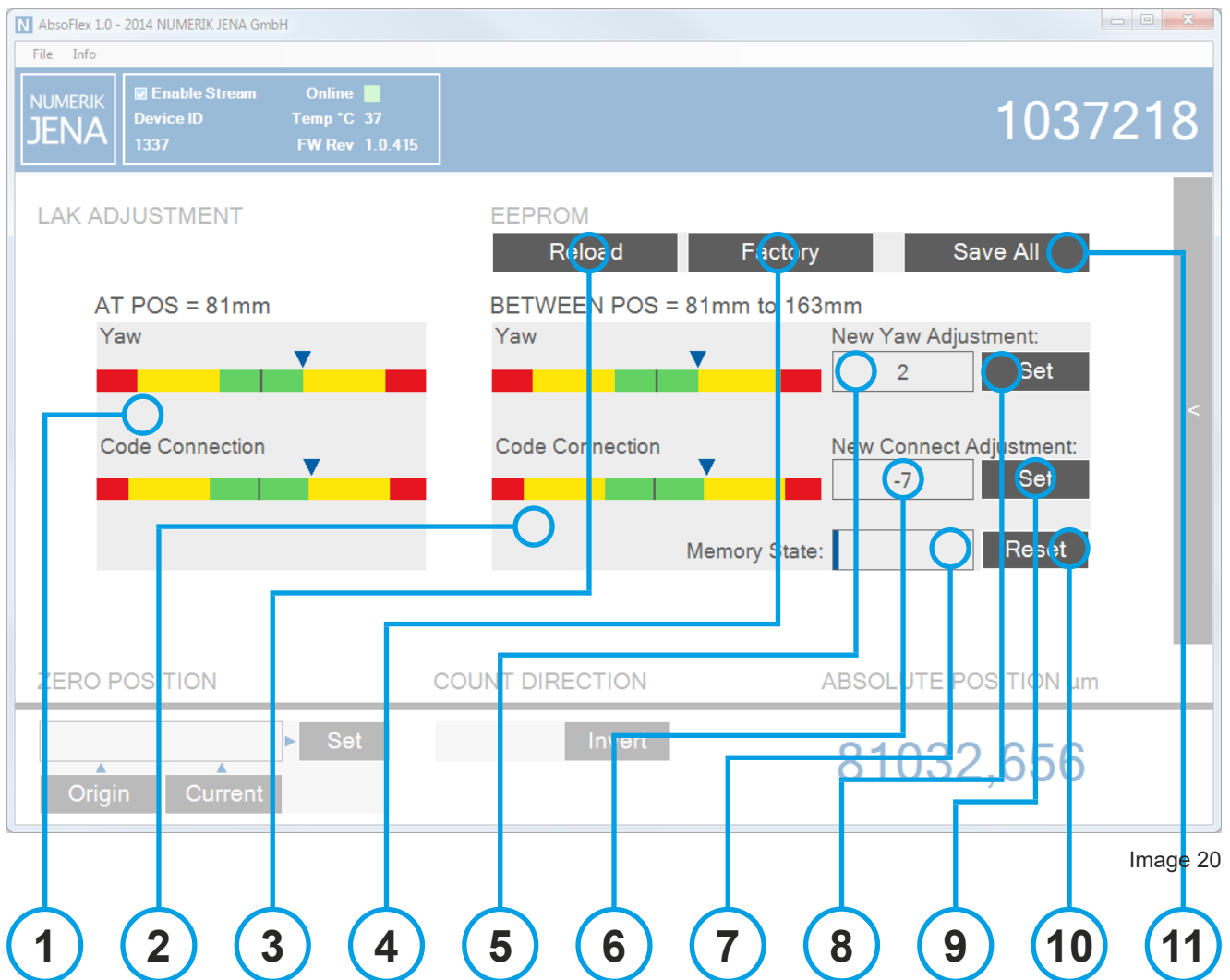

Image 20

- 1 Display for yaw and code connection errors at the current position
- 2 Display for average yaw and code connection error over the driven distance (after reset)
- 3 Reload - Button: discards changes to the device that have not been saved to the EEPROM yet
- 4 Factory - Button: loads factory settings from EEPROM
- 5 Calculated correction value for yaw error
- 6 Calculated correction value for code connection error
- 7 Used memory level during statistical calculation
- 8 Set - Button: update yaw with calculated correction value
- 9 Set - Button: update code connection with calculated correction value
- 10 Rest - Button: system reset when errors occur
- 11 Save All - Button: Save all current changes to EEPROM

Programming

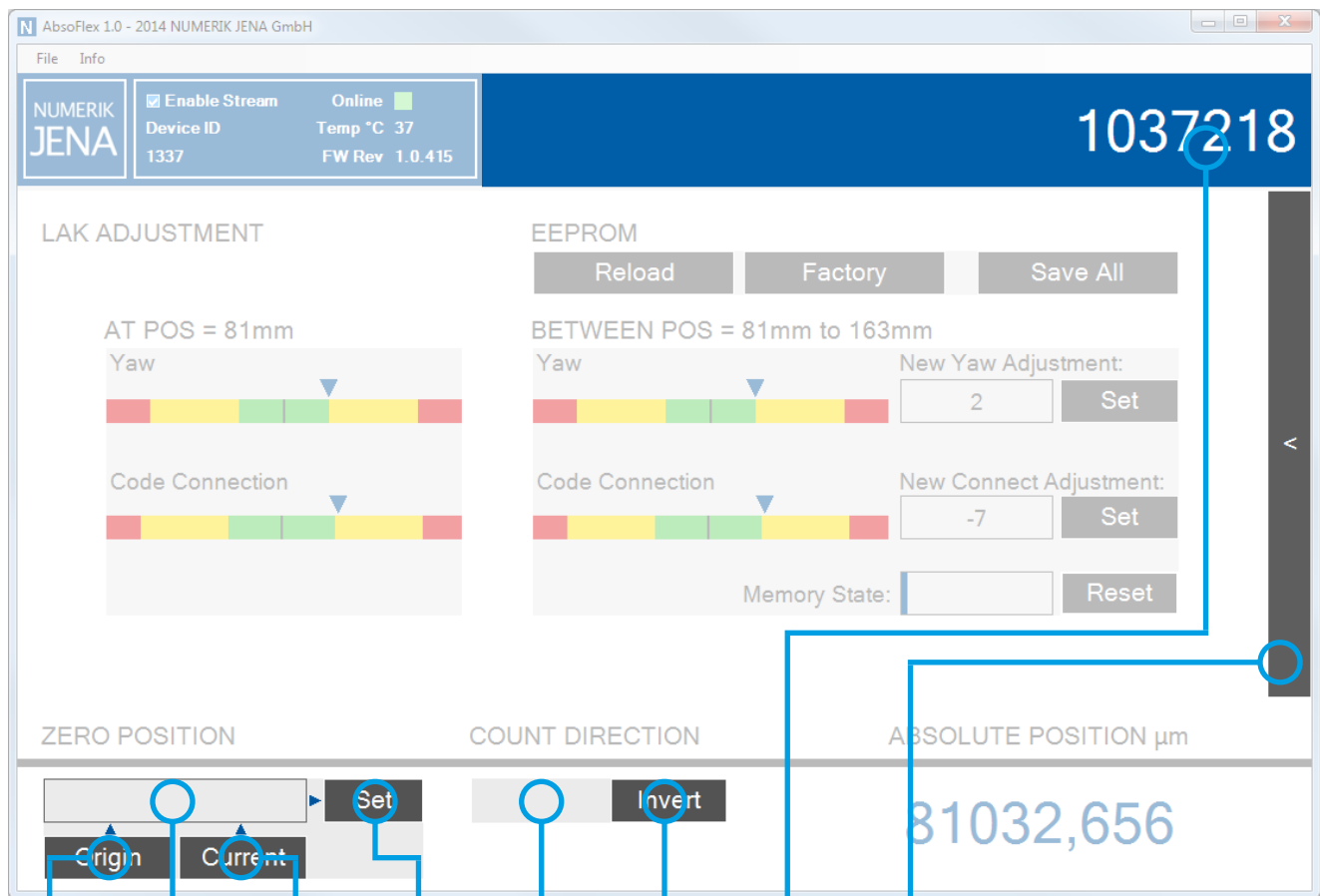

Image 21

- 1
- 2
- 3
- 4
- 5
- 6
- 7
- 8

- 1 Origin - Button: The beginning of the scale tape is set as zero-position
- 2 Display for the zero-position as a counter value
- 3 Current - Button: sets the current position as zero-position
- 4 Set - Button: programs the desired zero-position
- 5 Display for the current counting direction
- 6 Invert - Button: Inverts the counting direction in regard to the driving direction
- 7 Display for the absolute position as a counter value
- 8 Shift - Button: switches to the system margins panel

Diagnostics

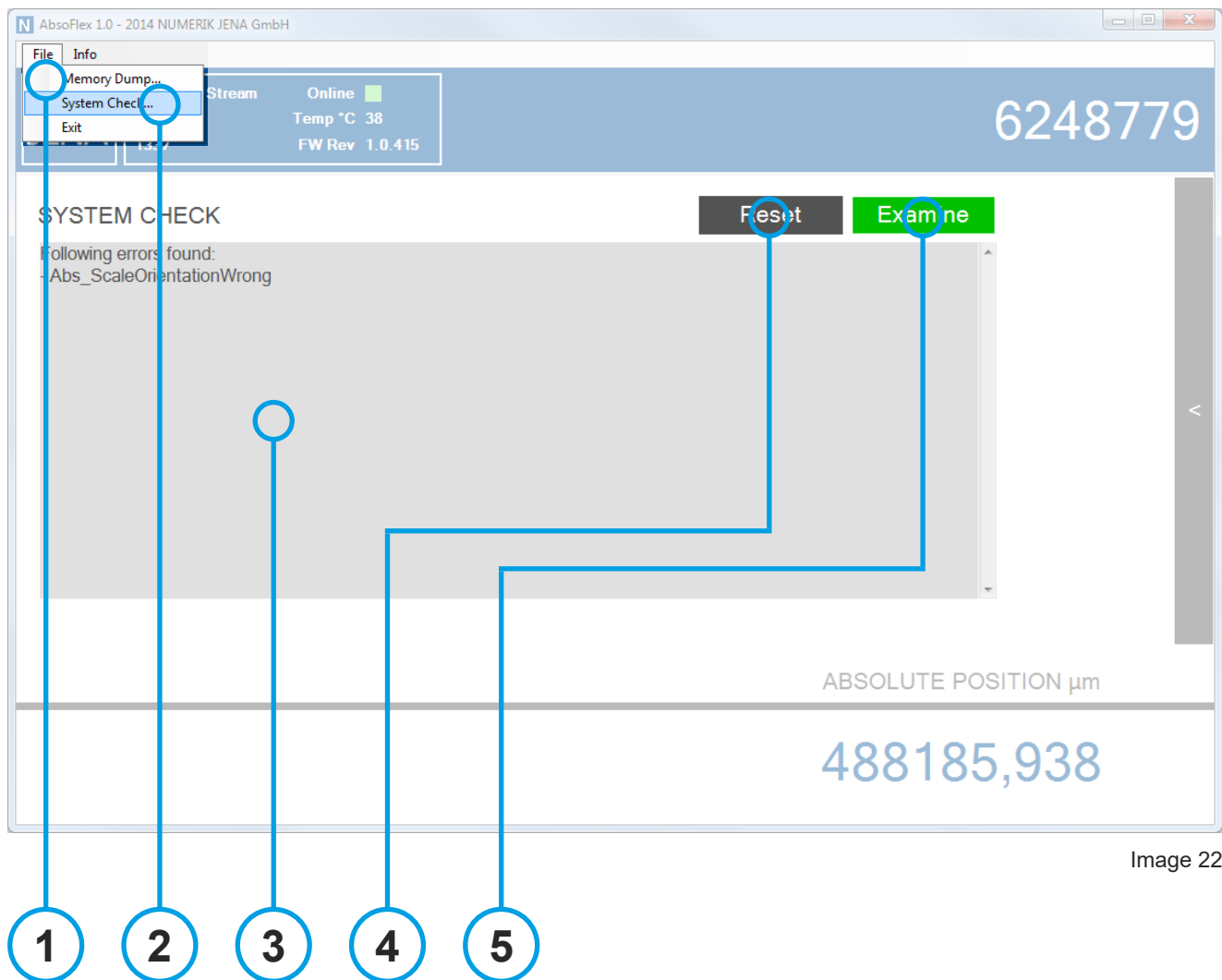

Image 22

- 1 Memory Dump: saves a copy of the entire memory in a file (for transmission to the support)
- 2 System Check: opens the software interface for error diagnosis
- 3 Log - Display: shows occurred errors
- 4 Reset - Button: resets the system when errors occur
- 5 Examine - Button: starts error analysis

7.4 Evaluation of the Signal Quality

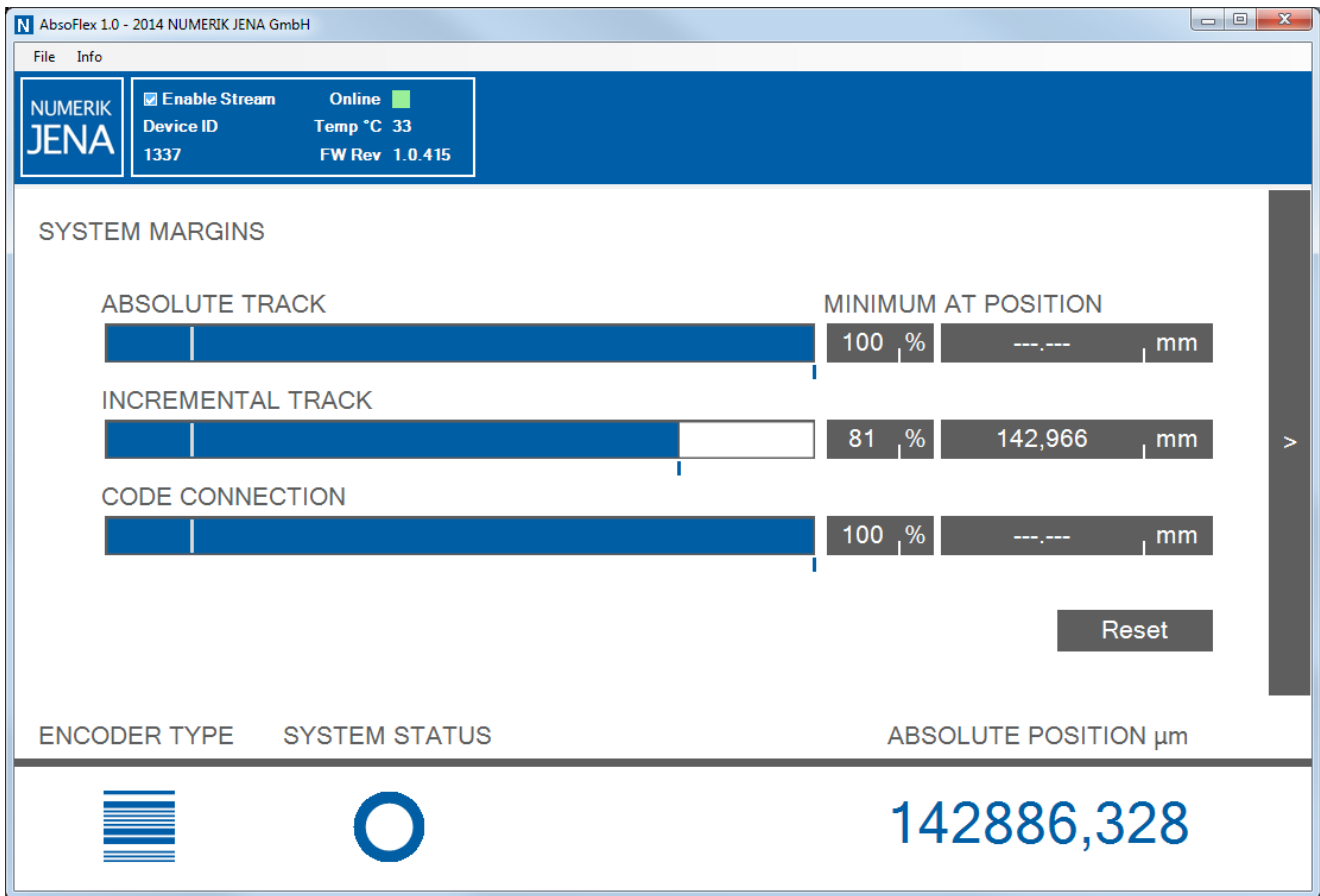

Image 23

The three blue bars show the current system margins of the device. The white line represents a system margin of 12.5%. If the current system margin value becomes less than 12.5% the device is in a “pre-warning” state. As long as the system margin stays above 0%, the device will function without any errors. When it reaches 0% it still works as long as no error bits are set. At this stage the probability is very high that an error bit is set at any moment.

The two columns on the right show the smallest system margins that have been reached since the last reset as well as the absolute position where this event occurred. These values do not correlate with the bars unless the device is at the same position displayed at the right.

7.5 Evaluation of the Mounting Conditions and Automatic Signal Adjustment

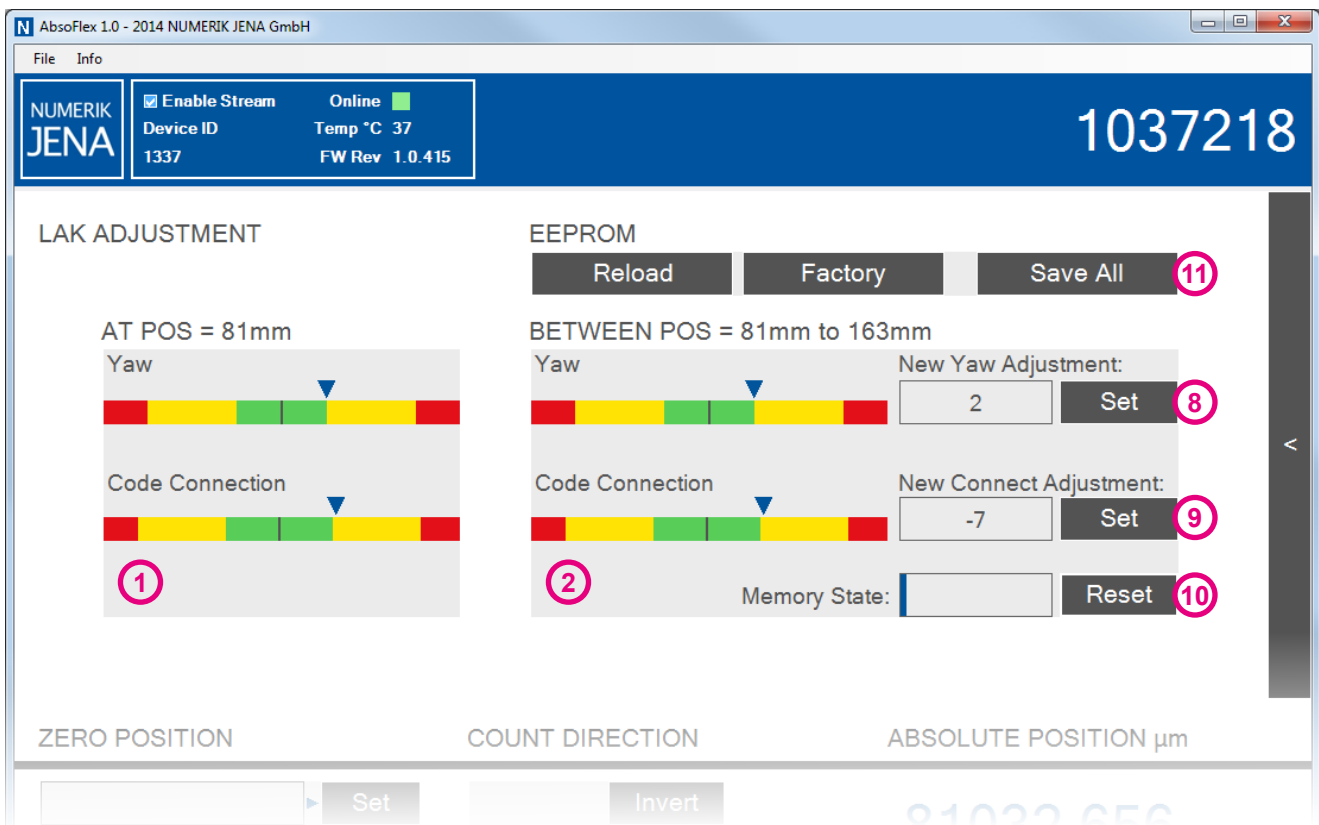

Image 24

The adjustment panel serves as a way to optimize code connection in regard to the mechanical mounting condition. As long as the distortion between head and tape is within the specified tolerances, the whole tolerance while moving the head in regard to the tape can be utilized.

1. Click the Reset - Button (10) to empty the memory.
2. Move the measuring head over the entire scale tape (multiple times, if possible).
3. The left bar graph (1) shows yaw and code connection errors at the current position. The right bar graph (2) shows the average errors over the driven distance.
4. Click the “New Yaw Adjustment” - Set-Button (8) to correct yaw errors.
5. Move the measuring head over the entire scale tape again (multiple times, if possible).
6. Click the “New Connection Adjustment” - Set-Button (9) to correct code connection errors.
7. Move the measuring head over the entire scale tape again (multiple times, if possible). The statistical error should be in the green segment (optimum).
8. Click the “Save All” - Button (11) to save the new parameters.

Error Treatment During Signal Adjustment

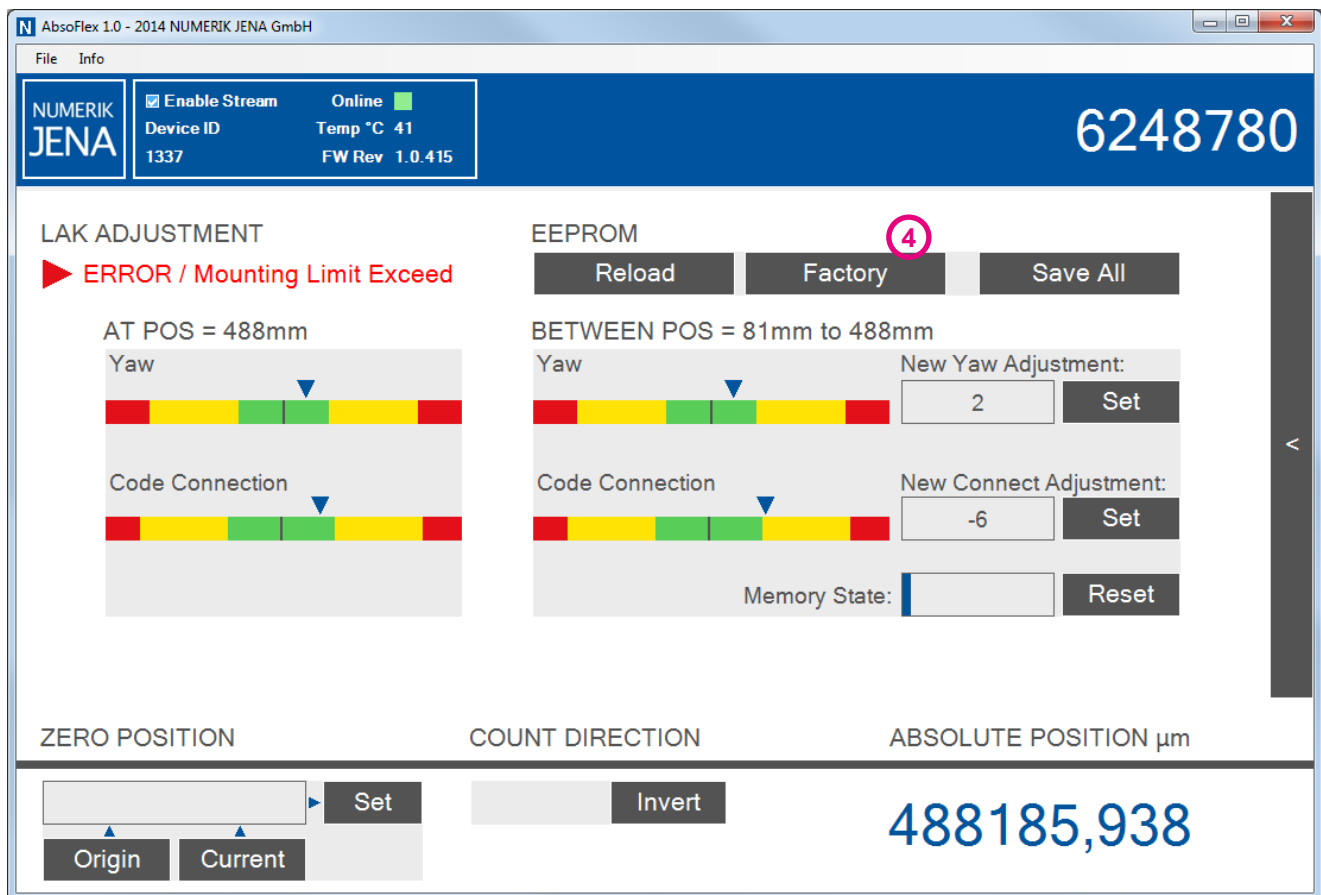

Image 25

If a "Mounting Limit Exceeded" - error message shows up after the automatic adjustment, the correction algorithms cannot handle the distortion between scale tape and measuring device. In this case it is recommended to reset the device to factory setting by clicking the "Factory" - Button (4). Check the mechanical mounting of the measuring system.

By resetting to factory settings the adjustment has to be repeated. This process is described at the beginning of this chapter.

7.6 Programming of the Logic Zero-Position and Counting Direction

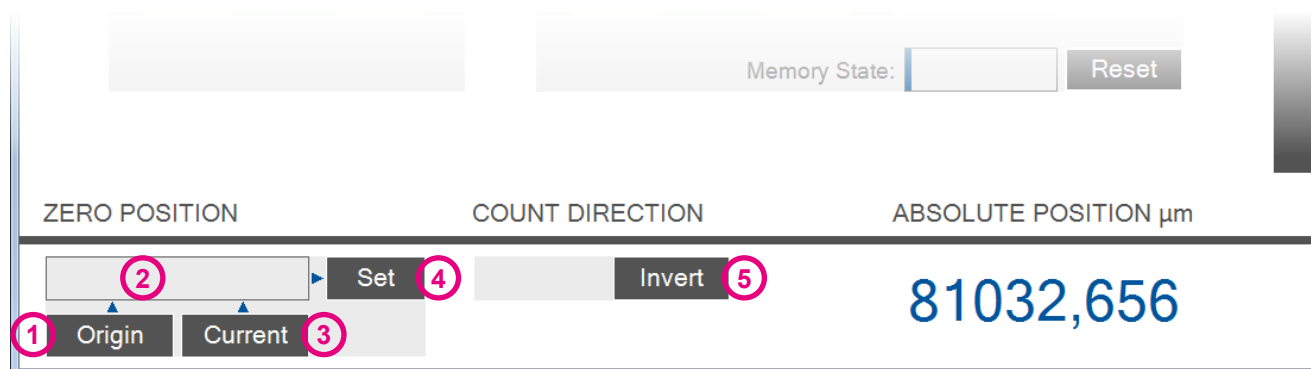

Image 26

Programming of the Logic Zero-Position*

Absolute measuring systems of NUMERIK JENA work with two separate internal position:

- Physical position which is derived from the code on the scale tape
- Logical position which is passed to the interface

It is possible to shift the logical position in regard to the physical position. This is achieved by setting a logical zero-position.

It is possible to save a physical position which is equivalent to the logical zero (2). Any counter value, that represents a valid physical position, can be entered here. Alternatively, by clicking the Origin - Button (1) this value can be set to zero or the current position can be entered by clicking the Current - Button (3).

The Set - Button (4) transmits the entered value to the measuring system.

Save all changes by clicking the Save All - Button (11)!

Programming of the Logical Counting Direction*

By clicking the Invert - Button (5) the counting direction of the measuring system can be inverted.

Please note: After changing the counting direction the logical zero-position has to be programmed as well!

Save all changes by clicking the Save All - Button (11).

* Not in combination with EnDat 2.2

8. General Installation Notes

8.1 Delivery Contents

Standard

- Kit LA scanning head (according to the ordered specification)
- SINGLEFLEX or DOUBLEFLEX scale tape (according to the ordered specification)
- Spacing gage for mounting the scanning head
- Installation notes / Information sheet

Optional

- ABSOFLEX USB-adapter for automatic signal adjustment
- ABSOFLEX - software incl. driver package
- Extension cable

8.2 Installation Position

- The installation position of the measuring system is arbitrary.
- In order to avoid contamination deposits, a vertical position for the scale tape is recommended.
- The operator of the measuring system is responsible for appropriate design measures to protect the encoders from contamination.
- In any installation position the scale tape surface and scanning window of the scanning head should be easily accessible for cleaning. Prevent contamination and foreign elements from having an influence on the operation!
- Use preferably slots or edges as an installation orientation for straight mounting of the scale tapes, particularly very long ones.
- For DOUBLEFLEX scale tapes, slots and edges also serve as a stop to prevent any displacement between the scale tape and the carrier tape.
- The measuring properties of the DOUBLEFLEX scale tape are the result of the adhesive layer between the scale tape and the carrier tape. Do not displace the scale tape and carrier tape relative to each other, or separate them from each other!
- If the DOUBLEFLEX scale tape will be mounted vertically, the fixing point must be located at the top. Otherwise the scale tape can detach itself from the carrier tape!
- If the DOUBLEFLEX scale tape will be mounted perpendicular, it must be supported and lie on an edge.

8.3 Mounting Steps

Hereafter the mounting steps for a Kit LA measuring system from NUMERIK JENA will be described.

- Please read the notes mentioned to the particular mounting steps thorough and follow the indicated sequence of mounting steps exactly!
- Maintain a tightening torque of 0.25 Nm for all screws!

1

- Preferably the tape should be mounted in a slot or along an edge.

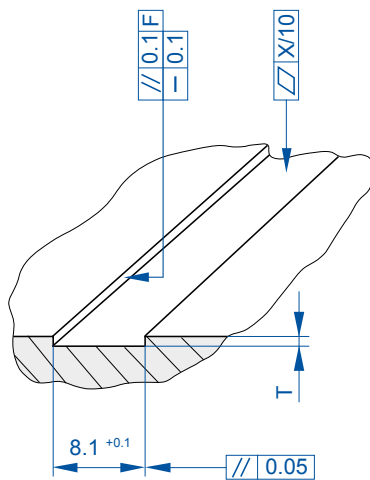

Mounting slot

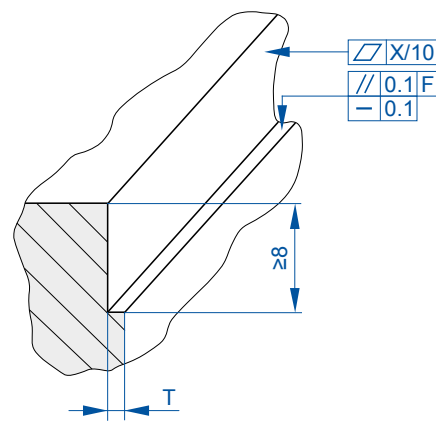

Mounting edge

Accuracy class	X
$\pm 3 \mu\text{m}$	0.009

F = Machine guideway

Scale tape	T
SINGLEFLEX	$0.5_{-0.1}$
DOUBLEFLEX	$0.7_{-0.1}$

- Please mark the future location of the scale tape before starting with the mounting. The alignment of the scale tape depends on the installation position of the scan head.
- The name plate of the scale tape indicates the side of the lowest measuring position. The cable outlet of the scanning head must point to the name plate.

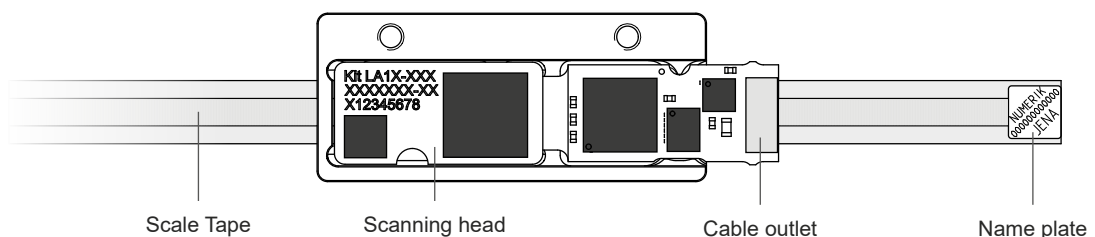

2

- Use a solvent to clean the adhesion surface of the machine (e.g. Acetone or Alcohol).
- Make sure that no contaminations remain on the machine's adhesion surface.
- Alien elements between the machine and scale tape cause local differences in the spacing between the scale tape and the scanning head. This may diminish the encoder's functionality and/or result in measuring errors.
- **ATTENTION:** Acetone and Alcohol are inflammable liquids!

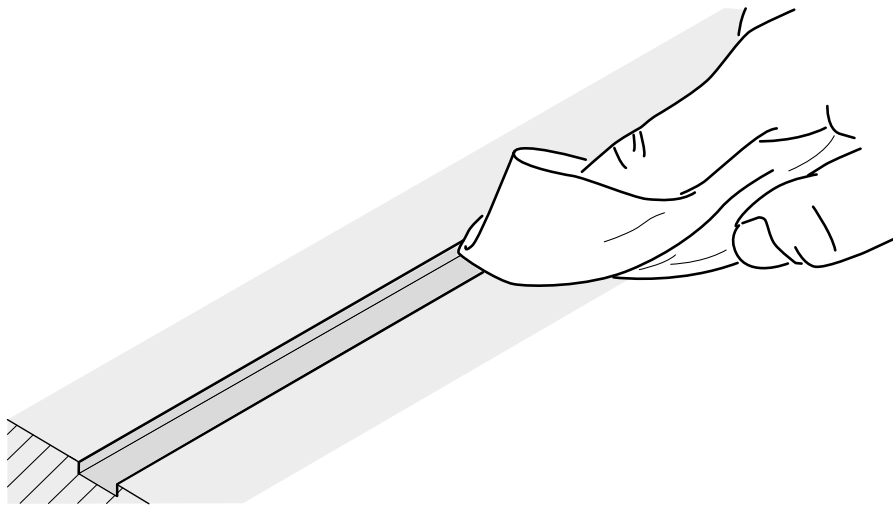

Information on installation of SINGLEFLEX and DOUBLEFLEX scale tapes



- The mounting steps of SINGLEFLEX and DOUBLEFLEX scale tapes are basically the same. But please pay attention to the following information on installation!
- The scale tape can be mounted in a slot already on the machine or along an edge already on the machine.
- Place the edge of the scale tape exactly on the marking for the beginning of the scale tape.
- Run the scale tape exactly along the slot or edge when applying it.
- If DOUBLEFLEX scale tapes are mounted vertically, mount them so that the scale tapes lie adjacent to the stop edge.

3

- If you use a DOUBLEFLEX scale tape, glue the fixing point first.
- Please pay attention to the use and safety instructions from the manufacturer of the adhesive!
- Place a drop of adhesive on the center of the fixing point.
- Recommended adhesives:
 - Cyanoacrylate adhesives such as Loctite 480 or Loctite 401
 - Epoxy resin

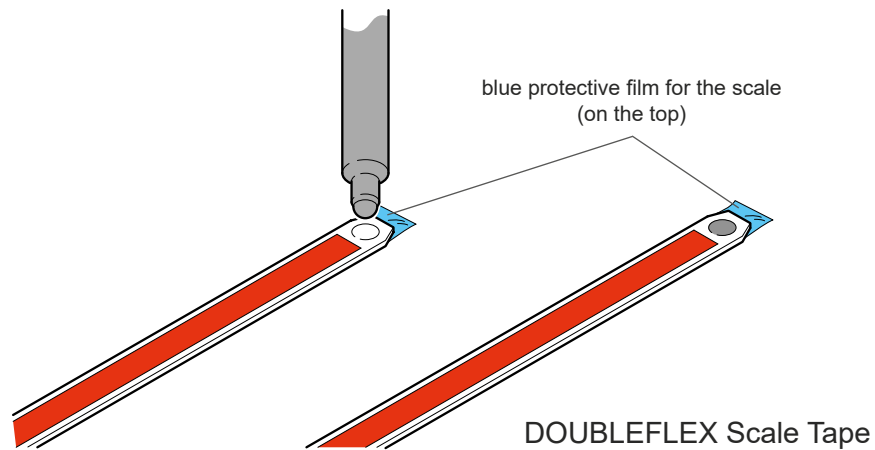

4

- Peel off ca. 70 mm of the red protective film on the back of the scale tape.
- The adhesive tape now exposed must not come into contact with other materials due to its strong adhesive force!
- Do not remove the blue transparent protective film from the scale tape yet!

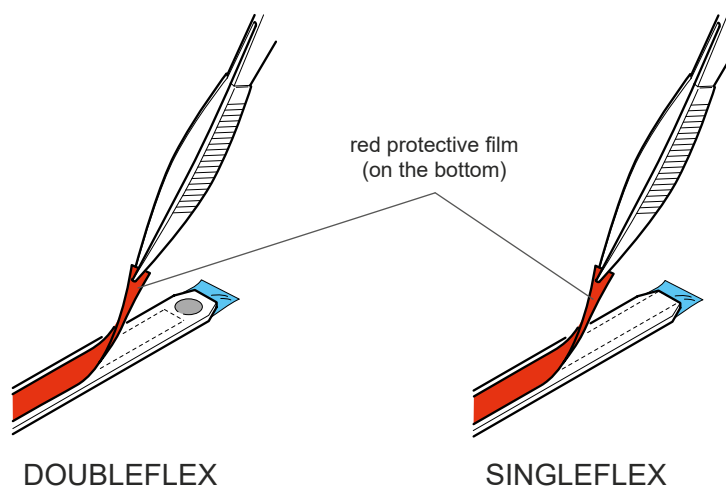

5

- Do not remove the blue transparent protective film from the scale tape yet!
- Remove the red protective film from the slot or edge.
- On the DOUBLEFLEX scale tape, apply the fix point with the drop of adhesive (at either the beginning or end of the scale tape) and at the same time secure the first ca. 50 mm of the scale tape.
- Place the end of the SINGLEFLEX scale tape from which the protective film has been removed against the front end stop (slot) or lateral stop (edge).

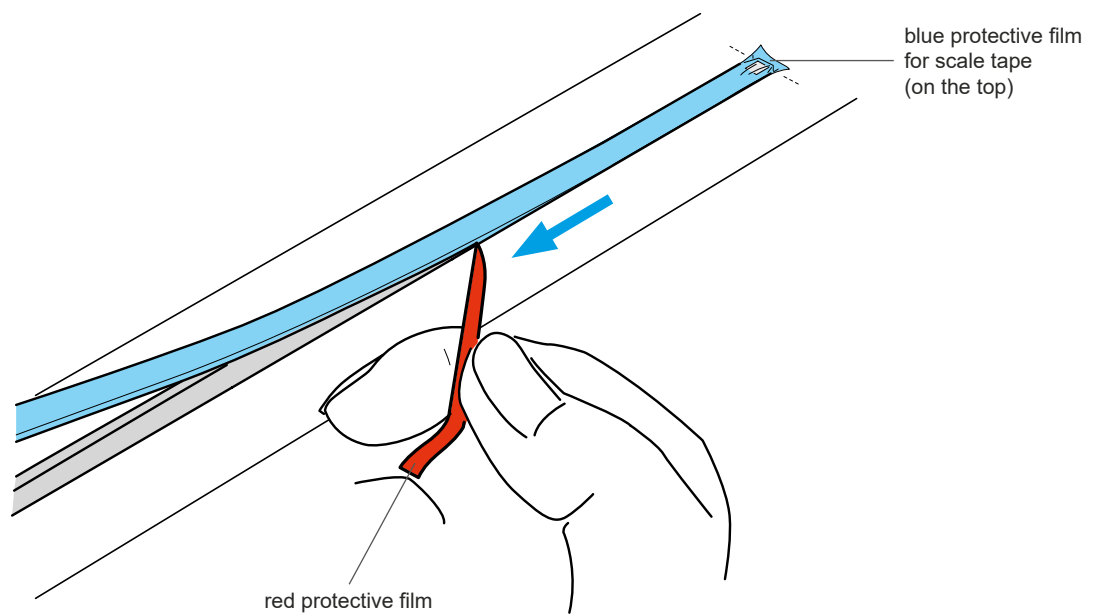

6

- Do not remove the blue transparent protective film from the scale tape yet!
- Press the scale tape with your forefinger and by the help of a soft, lint-free rag against the carrier over the entire length. Pull off the red protective film to the side. The pressure point should always be ca. 30 mm to 50 mm behind the point where the adhesive tape and the red protective film are being separated.
- **Only apply pressure to the scale tape from above and avoid lateral forces!**

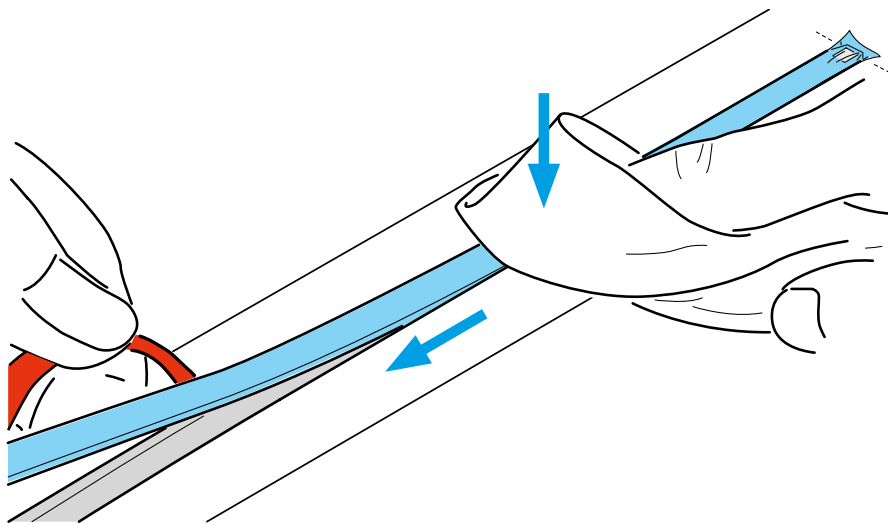

7

- Clean the mounting surfaces of the scanning head and the machine element.
- Remove the protective film from the scanning head.
- Clean the sensor surface of the scanning head with a soft and lint-free rag. Use a solvent if necessary (e.g. Acetone or Alcohol).
- **ATTENTION: Acetone and Alcohol are inflammable liquids!**

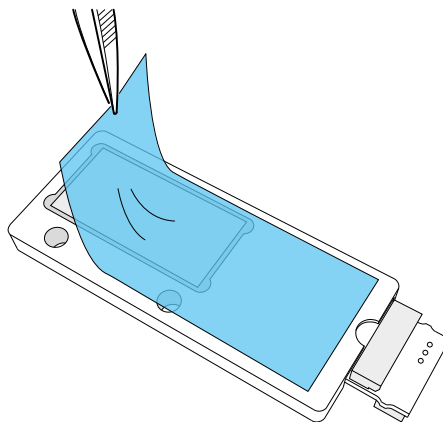

8

- Screw the scanning head onto the prepared mounting surface such that there is still some vertical clearance.
- Remove the blue transparent protective film (in case of DOUBLEFLEX scale tape, always begin at the fixing point) from the graduation of the scale tape.
- Clean the scale tape surface (graduation) of the scanning head with a soft and lint-free rag. Use a solvent if necessary (e.g. Acetone or Alcohol).
- ATTENTION: Acetone and Alcohol are inflammable liquids!

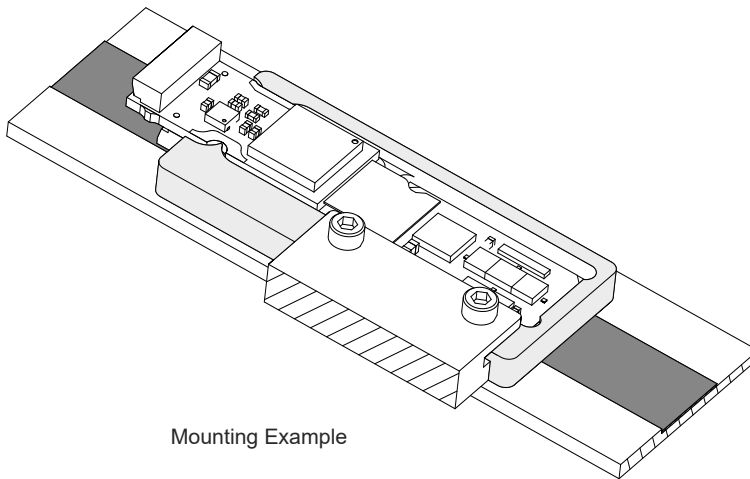

Mounting Example

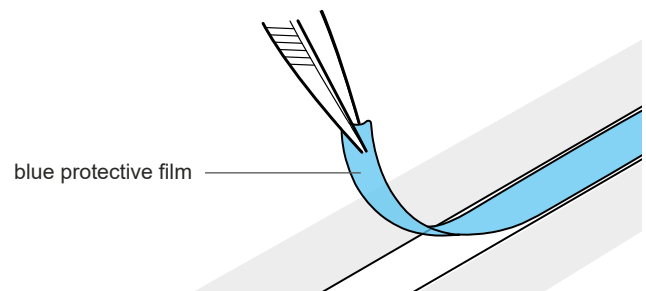

9

- Insert the spacing gage lengthwise between the scale tape surface and the scanning head.
- Push the scanning head against the spacing gage and tighten the two mounting screws alternately and evenly (tightening torque = 0.25 Nm). The spacing gage should barely be movable.
- Check the parallelism of the scanning head to the scale tape. Push the spacing gage ca. 5 mm to the left and right between the scanning head and scale tape, checking whether the clearance is the same.
- Remove the spacing gage cautiously. If it is difficult to remove the spacing gage, loosen the scanning head and repeat the mounting procedure. Otherwise the surface of the sensor module can be damaged!

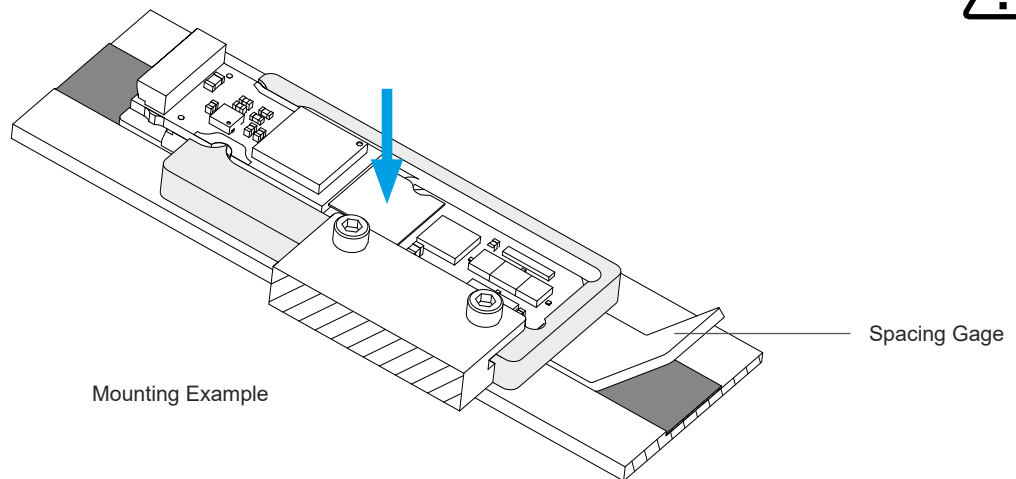

10

- Position the encoder cable including the strain relief near the scanning head.
- Connect the encoder cable to the evaluation electronics and pay attention to the pin assignment. The evaluation electronics must be switched off!
- After connecting the encoder cable switch the evaluation electronics on and test the functionality.
- If there are errors in the function or during measurement, please read chapter 10 “Troubleshooting” first. If these information are not helpful for your problem, please contact the technical support of NUMERIK JENA or an authorized representation in your country.

Information on Signal Adjustment after Mounting

- The measuring systems from NUMERIK JENA provide the possibility to adjust the signals electronically after mounting. This is useful for signal optimization regarding to the individual mounting conditions. This minimizes short-wave position errors (interpolation errors), positively affecting the operational behavior of the encoder.
- For further information about the signal adjustment, see point 7.5.

9. Cleaning



9.1 Measuring System

- Depending on the measuring system's mounting attitude and the ambient conditions, it may be necessary to clean the scale tape surface and sensor surface of the scanning head (scanning window) occasionally.
- If the monitoring signal output of the scanning head is used, the encoder indicates if cleaning is necessary.
- When cleaning the components, ensure that the scanning window and scale tape are not scratched by any deposited particles!
- Dirt should be removed using a soft brush or oil-free compressed air.
- Use cotton balls or a soft and lint-free rag for cleaning. Use a solvent if necessary (e.g. Acetone or Alcohol).
- ATTENTION: Acetone and Alcohol are inflammable liquids!

9.2 Scale Tape

- Avoid to contact the solvent and the adhesive tape! This could start to dissolve the adhesive and reducing the adhesive force. Furthermore the scale tape can be detached totally.
- Please always wipe the DOUBLEFLEX scale tape lengthwise. Wiping it crosswise could result in an offset of the scale tape relative to the carrier tape and leading to errors in the function of the measuring system.
- Ensure that no solvent seeps under the scale tape! This could adversely affect the adhesive layer between the scale tape and carrier tape, thereby loosening the scale tape.

10. Troubleshooting

The functions of all scanning heads and accuracy of all scale tapes are tested before the encoders are shipped. However, if troubles or problems should occur, please read the following points in the chart and proceed according to this information.

If this is not helpful, please contact the technical support of NUMERIK JENA GmbH or one of our authorized subsidiaries. You will find respective contact data on the NUMERIK JENA website www.numerikjena.de.

10.1 Typical Errors

Error	Possible causes	Solution
No measuring signal	<ul style="list-style-type: none"> No power at the scanning head 	<ul style="list-style-type: none"> Check the status of the evaluation electronics Check the connection assignment between the encoder and the evaluation electronics
Error message from the evaluation electronics	<ul style="list-style-type: none"> Following error due to temporary failure of the measuring signal Self-diagnosis of the measuring system has found an error 	<ul style="list-style-type: none"> Check the assignment of the scale tape to the scanning head p.r.n. readjust mechanically Check for contaminations
Counting error (compared to a standard)	<ul style="list-style-type: none"> Mounting error / Contamination 	<ul style="list-style-type: none"> Readjust electronically with ABSOFLEX - Software¹
System reserve exhausted		
Despite optimal mounting conditions the measuring system alerts a system error	<ul style="list-style-type: none"> Orientation of the scale to the scan head in measurement direction (X-axis) wrong 	<ul style="list-style-type: none"> Check the orientation of the scale tape
The ABSOFLEX - software is not able to get a connection to the measuring system	<ul style="list-style-type: none"> USB-driver not installed Permissible length of the USB-cable (Host to scan head) exceeded 	<ul style="list-style-type: none"> Check correct installation of the driver Check permissible cable length² reconnect the USB-connection

Chart 20

¹ see also point 7.5

² see also point 7.2

10.2 FAQ

1	<p>The adjustment (yaw and code connection) does not work. An error message keeps showing up. The arrow stays out of the green segment of the bar graph even after pressing "Set".</p> <p>The correction algorithms are used to improve the tolerance band. It is not possible to correct distortion errors that are worse than an equivalent to the width of a bit period ($>0.5^\circ$). If this threshold is exceeded, check the mechanical mounting.</p>
2	<p>There are two sections in the adjustment interface. Why?</p> <p>The left section displays errors at the current position (smoothed to some degree). The right section shows a statistical error over the driven distance. The statistical evaluation is essential for a good error correction. The best outcome is achieved by moving the measuring device over the entire scale tape.</p>
3	<p>The measuring device is mechanically adjusted optimally. Nonetheless, the absolute track is on 0% and the error bit is set. Why?</p> <p>The measuring device does not recognize the code from the scale tape. The most common reason for this error is when measuring device and scale tape are not aimed at the same direction. Check the alignment of tape and device (rotate either by 180°).</p>

10.3 System Check with the ABSOFLEX - Software

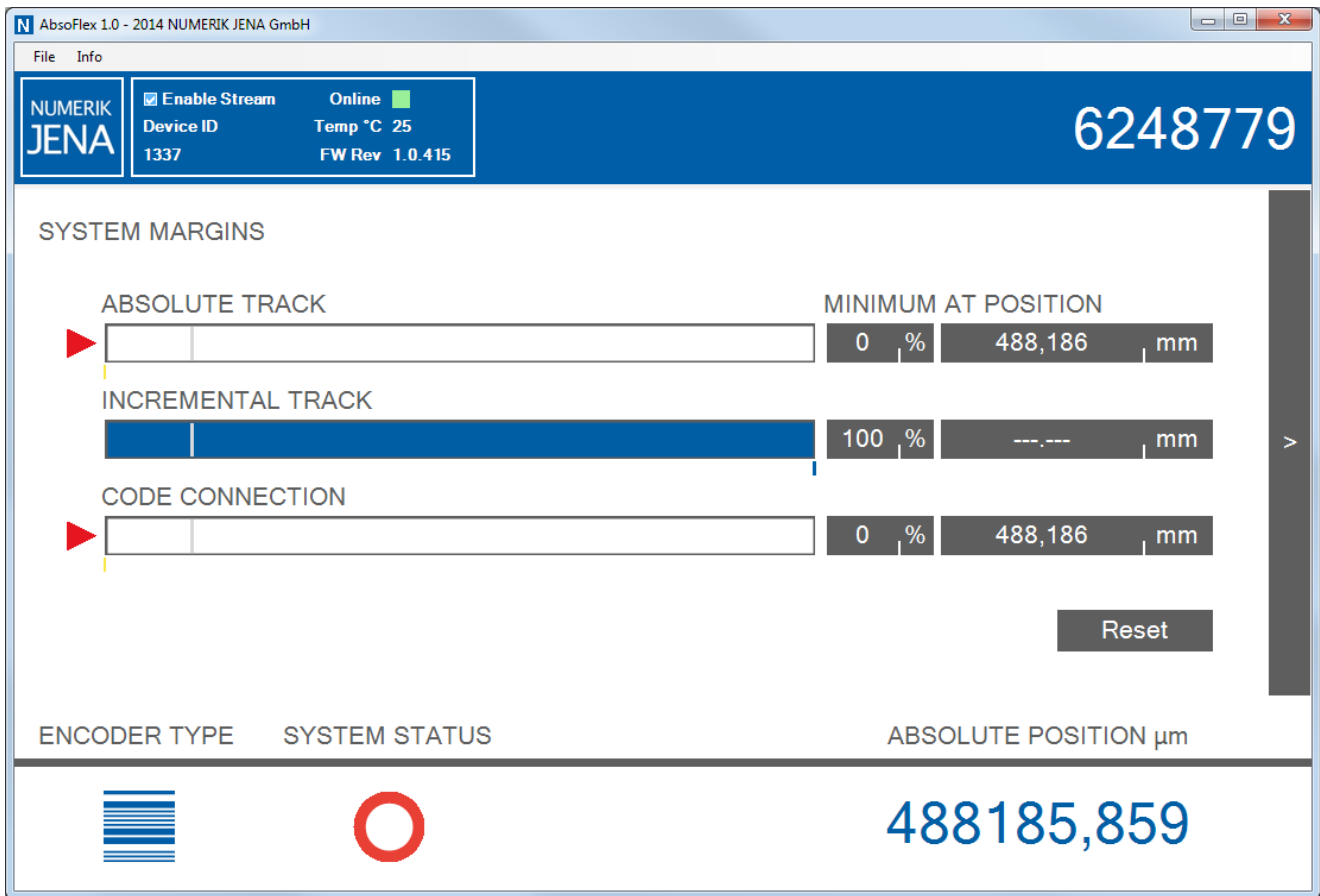

Image 27

If system errors occur that have not been discussed in this chapter, the ABSOFLEX - software provides a system check.

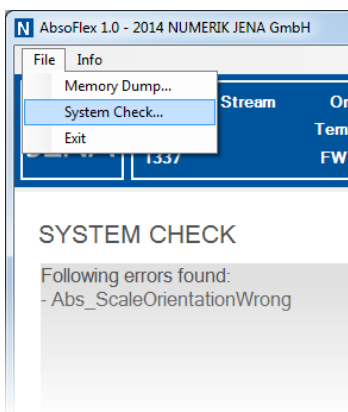

Image 28

To access it, click on "File" -> "System Check" (2) as illustrated in the image to the left. A diagnose interface will be opened.

IMPORTANT: The measuring device has to be stationary in order to perform the diagnosis correctly.

By pressing the Examine - Button (5) the diagnose starts.

The results appear in the grey log window (3). Forward these results to the technical support of NUMERIK JENA or any authorized subsidiary.

To create a copy of the internal memory of the device, click on "File" -> "Memory Dump" (1). This information might be useful for the technical support.

11. Ordering Key

11.1 Scanning Head

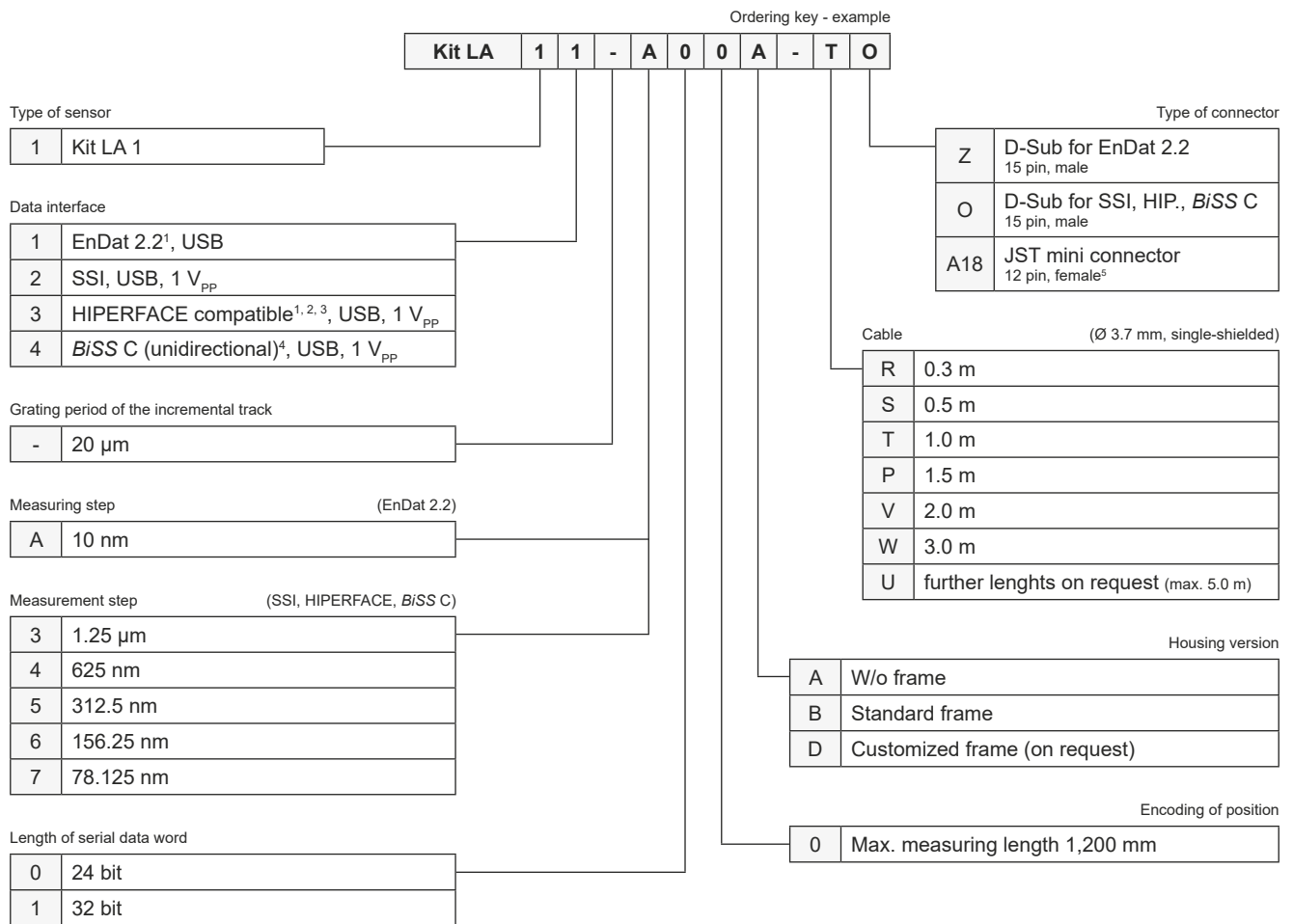

Optional Accessory

Description	Order-no.
ABSOFLEX USB-Adapter	1135558-01
USB-Kabel (1.8 m, Type A to Mini-USB Type B)	687661-01

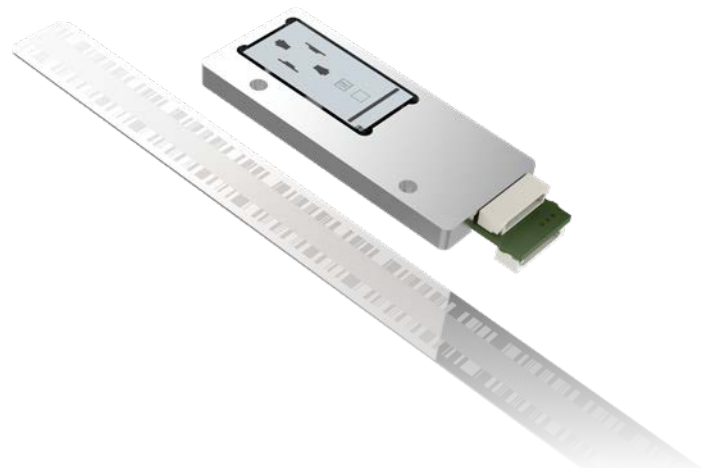

¹ Only compatible for serial data word length = 32 bit

² Only in combination with measuring step 625 nm (choice 4)

³ HIPERFACE is a trade mark of SICK Stegmann GmbH

⁴ BiSS is a trade mark of iC-Haus GmbH

⁵ not in combination with EnDat 2.2 interface

11.2 Scale Tape

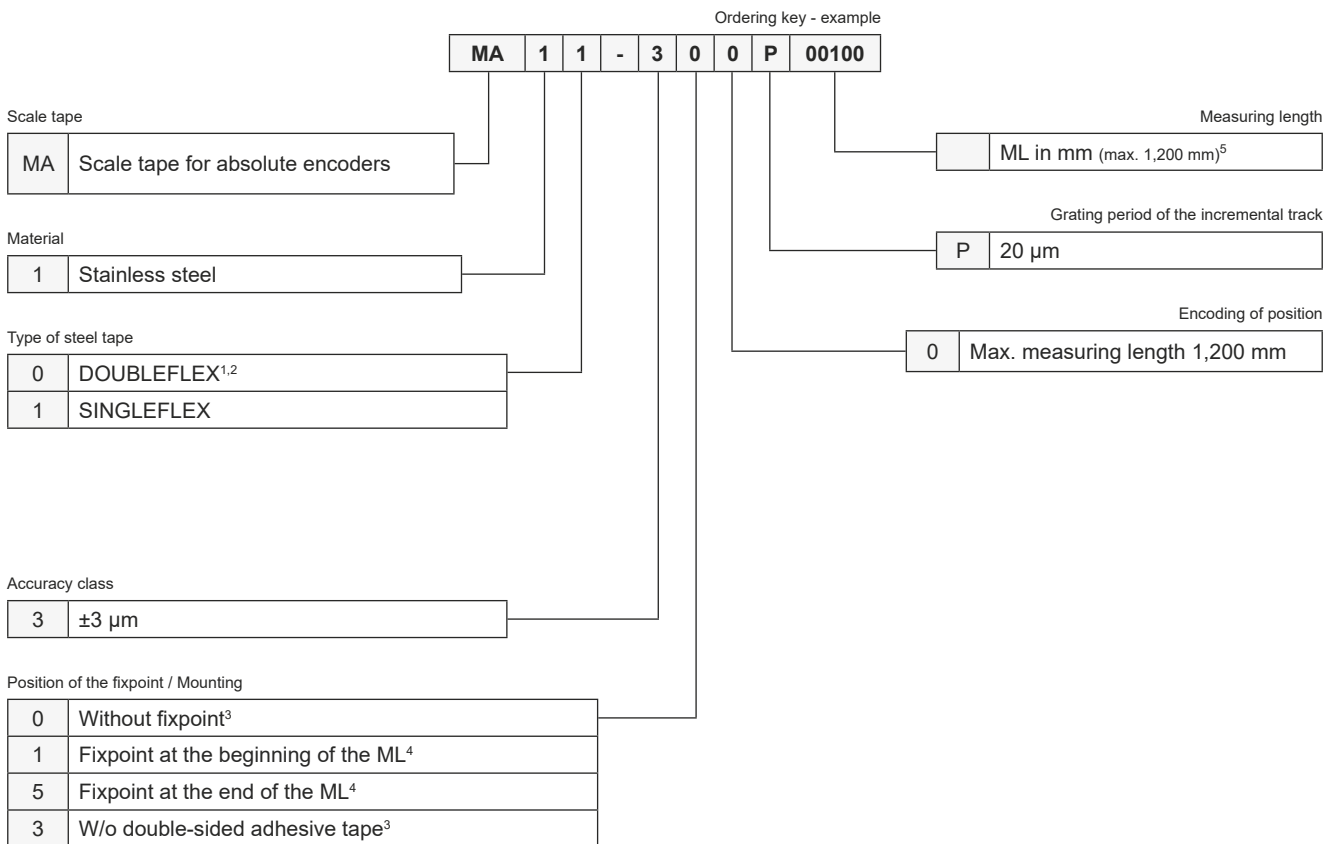

¹ Min. ML = 100 mm; max. ML = 1,200 mm

² Not suitable for vacuum applications

³ Only for SINGLEFLEX

⁴ Only for DOUBLEFLEX scale tapes

⁵ Total length = ML + x (SINGLEFLEX x = 17 mm, DOUBLEFLEX x = 25 mm)
ML - Measuring length

NUMERIK JENA GmbH
Im Semmicht 4
07751 Jena
Germany

Phone: +49 3641 4728-0
E-Mail: info@numerikjena.de
www.numerikjena.de

